

MPP 250 TOOLING CHART

WTC Machinery, LLC

W1222 Linden Road

Ixonia, Wisconsin 53036 USA

Phone: 800.248.8405 or 262.567.3993

Fax: 262.567.4304 or 262.569.4850

Table of Contents

Case	pg. 1-4
Caterpillar	pg. 4-16
Dresser	pg. 16-21
Fiat	pg. 21-29
Hitachi	pg. 29-30
John Deere	pg. 30-36
Kobelco	pg. 36
Komatsu	pg. 36-48
Liebherr	pg. 48-49
Linkbelt	pg. 49
Massey Fergusson	pg. 49
Terex	pg. 49-50
Volvo	pg. 50

Assembly Tools

Disassembly Tools
Pin Diameter between
0.87" and 1.25"
(22,0 and 31,7 mm)

Disassembly Tools
Pin Diameter between
1.25" and 1.37"
(31,7 and 34,9 mm)

Pin Assembly Tools (PAT)
See Tooling Chart for Part Numbers

Disassembly Tools
Pin Diameter between
1.37" and 2.12"
(34,9 and 53,8 mm)

Disassembly Tools
Pin Diameter between
2.12" and 2.50"
(53,8 and 63,5 mm)

Disassembly Tools
Pin Diameter between
2.50" and 2.75"
(63,5 and 69,8 mm)

Disassembly Tools
Pin Diameter between
2.75" and 3.45"
(69,8 and 87,6 mm)

17	Bushing Adapter (part of MPP250)	A4160
16	Extra-Large Backing Bushing	A4157
15	Large Backing Bushing	A3541
14	Medium Backing Bushing	A3540
13	Small Backing Bushing	A3539
12	Medium Pin Tool	A3537
11	Small Pin Tool	A3536
10	Pin Tool Holder / Sprocket Hub Tool	A3535
9	1.250" Pin Tool	B3635
8	Short 2.375" Pin Tool	B3632
7	Long 2.375" Pin Tool	B3631
6	Short 2.000" Pin Tool	B3608
5	Long 2.000" Pin Tool	B3607
4	Long 2.677" Pin Tool	B3606
3	Short 2.677" Pin Tool	B3605
2	Cam-lock Adaptor - Backing Side	B2867
1	Cam-lock Adaptor - Cylinder Side	B2866
ITEM	DESCRIPTION	PART NO.

MPP250 Pin Press Tooling

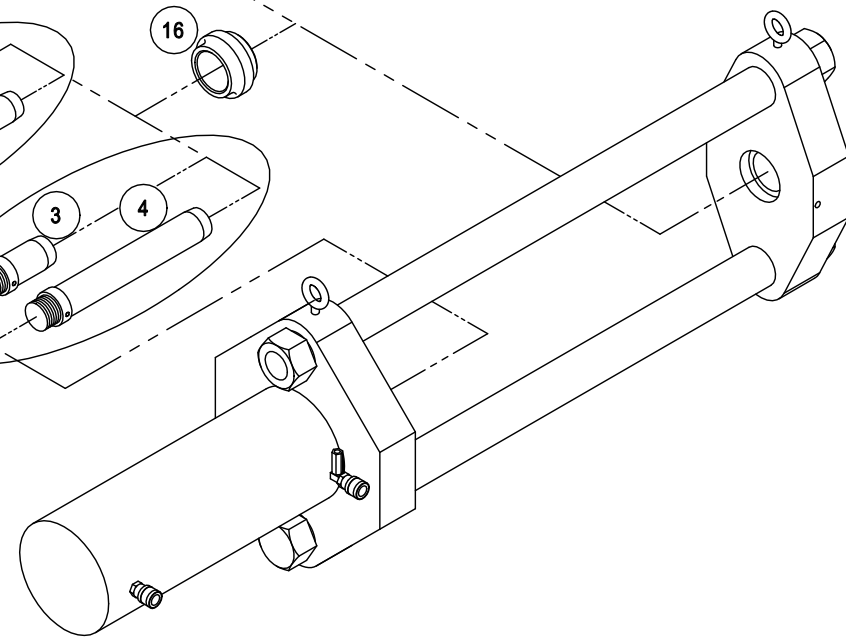

WTC Machinery
MPP 250 Tooling Chart

				Pin Dimensions				Disassembly Tools	
Make	Model	Comments	Type	Dia	Length	Pitch	PAT	Pin Tool	Back. Bush.
CASE	350		FLUSH	0.993	5.22	5.875	915068	A3536	A3539
CASE	400		FLUSH	0.993	5.22	5.875	915068	A3536	A3539
CASE	420		FLUSH	0.993	5.22	5.875	915068	A3536	A3539
CASE	450			1.0625	5.375	5.875	915225	A3536	A3539
CASE	450		FLUSH	1.187	5.38	5.75	915066	A3536	A3539
CASE	500		FLUSH	0.993	5.22	5.875	915068	A3536	A3539
CASE	550	JAK0013968 & DN	SEALED	1.129	6.457	5.998	915066	A3536	A3539
CASE	550		SEALED	1.129	6.575	6.29	915144	A3536	A3539
CASE	550		SALT	1.129	6.575	6.29	915144	A3536	A3539
CASE	560		FLUSH	0.993	5.22	5.875	915068	A3536	A3539
CASE	600			1.0625	5.375	5.875	915225	A3536	A3539
CASE	650		SEALED	1.318	7.224	6.734	915011	A3537	A3540
CASE	650		SALT	1.318	7.224	6.735	915158	A3537	A3540
CASE	700	S/N 7070351 & DN	RECESSED	1.248	6.5	6.25	915056	A3536	A3539
CASE	750		RECESSED	1.375	6.94	6.25	915069	B3635	A3541
CASE	800		RECESSED	1.248	6.5	6.25	915056	A3536	A3539
CASE	850		SEALED	1.375	6.94	6.25	915009	B3635	A3541
CASE	1000	HD	RECESSED	1.375	6.94	6.25	915069	B3635	A3541
CASE	1000		RECESSED	1.248	6.5	6.25	915056	A3536	A3539
CASE	1000		SEALED	1.375	6.94	6.25	915009	B3635	A3541
CASE	1150		RECESSED	1.375	6.94	6.25	915069	B3635	A3541
CASE	1150		SEALED	1.375	6.94	6.25	915009	B3635	A3541

WTC Machinery
MPP 250 Tooling Chart

				Pin Dimensions				Disassembly Tools	
Make	Model	Comments	Type	Dia	Length	Pitch	PAT	Pin Tool	Back. Bush.
CASE	1150		SEALED	1.375	6.94	6.25	915011	B3635	A3541
CASE	1450		SEALED	1.752	9.075	8.02	915070	B3635	A3541
CASE	1550		SEALED	1.753	9.06	8.02	915226	B3635	A3541
CASE	1550		SALT	1.753	9.06	8.02	915006	B3635	A3541
CASE	1150B		SEALED	1.5	8.1	6.678	915067	B3635	A3541
CASE	1150D	7310051 & PRIOR	SEALED	1.44	8.11	6.678	915052	B3635	A3541
CASE	1150D	7310051 & PRIOR	SALT	1.44	8.11	6.678	915052	B3635	A3541
CASE	1150E		SALT	1.44	8.11	6.678	915052	B3635	A3541
CASE	1150E		SEALED	1.44	8.11	6.678	915052	B3635	A3541
CASE	1155D	7311001 & PRIOR	SALT	1.44	8.11	6.678	915052	B3635	A3541
CASE	1155D	7311001 & PRIOR	SEALED	1.44	8.11	6.678	915052	B3635	A3541
CASE	1155E		SALT	1.44	8.11	6.678	915052	B3635	A3541
CASE	1155E		SEALED	1.44	8.11	6.678	915052	B3635	A3541
CASE	1450B		SEALED	1.752	9.075	8.02	915070	B3635	A3541
CASE	1450B	S/N 8383001 & UP	SEALED	1.753	9.06	8.02	915226	B3635	A3541
CASE	1450B		SALT	1.753	9.06	8.02	915006	B3635	A3541
CASE	1455B		SEALED	1.752	9.075	8.02	915070	B3635	A3541
CASE	1455B	S/N 8480001 & UP	SEALED	1.753	9.06	8.02	915226	B3635	A3541
CASE	1455B		SALT	1.753	9.06	8.02	915006	B3635	A3541
CASE	310G		FLUSH	0.993	5.22	5.875	915068	A3536	A3539
CASE	350B		SEALED	0.994	5.219	5.875	915224	A3536	A3539

WTC Machinery
MPP 250 Tooling Chart

				Pin Dimensions				Disassembly Tools	
Make	Model	Comments	Type	Dia	Length	Pitch	PAT	Pin Tool	Back. Bush.
CASE	450A	S/N 3030801 & UP	SEALED	1.25	6.54	6	915069	A3537	A3540
CASE	450B		SEALED	1.25	6.54	6	915069	A3537	A3540
CASE	450C		SALT	1.129	6.46	6	915046	A3536	A3539
CASE	450C		SEALED	1.129	6.457	5.998	915066	A3536	A3539
CASE	455C		SALT	1.129	6.46	6	915046	A3536	A3539
CASE	550E		SEALED	1.129	6.575	6.29	915144	A3536	A3539
CASE	550E		SALT	1.129	6.575	6.29	915144	A3536	A3539
CASE	550G	w/ Floating Bushing	SEALED	1.129	6.575	6.29	915144	A3536	A3539
CASE	850B		SEALED	1.375	6.94	6.25	915009	B3635	A3541
CASE	850D		SALT	1.318	7.22	6.25	915011	A3537	A3540
CASE	850D		SEALED	1.375	6.94	6.25	915011	B3635	A3541
CASE	850D		SEALED	1.318	7.224	6.734	915011	A3537	A3540
CASE	850D		SALT	1.318	7.224	6.735	915158	A3537	A3540
CASE	850E	AFTER 4-1-89	SEALED	1.318	7.224	6.734	915011	A3537	A3540
CASE	850E	AFTER 4-1-89	SALT	1.318	7.224	6.735	915158	A3537	A3540
CASE	850G		SEALED	1.318	7.224	6.734	915011	A3537	A3540
CASE	850G		SALT	1.318	7.224	6.735	915158	A3537	A3540
CASE	850H		SEALED	1.318	7.224	6.734	915011	A3537	A3540
CASE	850H		SALT	1.318	7.224	6.735	915158	A3537	A3540
CASE	850K		SEALED	1.318	7.224	6.734	915011	A3537	A3540
CASE	850K		SALT	1.318	7.224	6.735	915158	A3537	A3540

WTC Machinery
MPP 250 Tooling Chart

				Pin Dimensions				Disassembly Tools	
Make	Model	Comments	Type	Dia	Length	Pitch	PAT	Pin Tool	Back. Bush.
CASE	855D		SALT	1.318	7.22	6.25	915011	A3537	A3540
CASE	855D		SEALED	1.375	6.94	6.25	915011	B3635	A3541
CASE	855D	AFTER 4-1-89	SEALED	1.318	7.224	6.734	915011	A3537	A3540
CASE	855D	AFTER 4-1-89	SALT	1.318	7.224	6.735	915158	A3537	A3540
CATERPILLAR	30		RECESS	1.314	7	6.735	915011	A3537	A3540
CATERPILLAR	215	w/ 9/16 BOLT	SEALED	1.315	6.37	6.735	915089	A3537	A3540
CATERPILLAR	215	w/ 5/8 BOLT	SEALED	1.314	7.22	6.735	915011	A3537	A3540
CATERPILLAR	219		SEALED	1.442	8.12	7.48	915052	B3635	A3541
CATERPILLAR	225	EXC	SEALED	1.314	7.22	6.735	915011	A3537	A3540
CATERPILLAR	225		SEALED	1.252	9.06	7.984	915003	A3537	A3540
CATERPILLAR	227		SEALED	1.252	9.06	7.984	915003	A3537	A3540
CATERPILLAR	229		SEALED	1.252	9.06	7.984	915003	A3537	A3540
CATERPILLAR	235	EXC	SEALED	1.252	9.06	7.984	915003	A3537	A3540
CATERPILLAR	235		SEALED	1.877	9.88	8.5	915012	B3635	A3541
CATERPILLAR	245	EXC	SEALED	2.253	11.259	10.25	915005	B3607/8	A3541
CATERPILLAR	311	EXC	SEALED	1.321	7.01	6.75	915059	A3537	A3540
CATERPILLAR	312	EXC	SEALED	1.321	7.01	6.75	915059	A3537	A3540
CATERPILLAR	315	EXC	SEALED	1.442	8.15	7.48	915140	B3635	A3541
CATERPILLAR	317	EXC	SEALED	1.442	8.15	7.48	915140	B3635	A3541
CATERPILLAR	320	EXC	SEALED	1.442	8.15	7.48	915140	B3635	A3541
CATERPILLAR	322	EXC	SEALED	1.442	8.15	7.48	915140	B3635	A3541

WTC Machinery
MPP 250 Tooling Chart

				Pin Dimensions				Disassembly Tools	
Make	Model	Comments	Type	Dia	Length	Pitch	PAT	Pin Tool	Back. Bush.
CATERPILLAR	325	EXC	SEALED	1.654	9.055	8	915141	B3635	A3541
CATERPILLAR	330	EXC	SEALED	1.811	9.665	8.5	915015	B3635	A3541
CATERPILLAR	345	EXC	SEALED	2.003	11.438	8.5	915142	B3635	A3541
CATERPILLAR	350		SEALED	2.003	11.438	9	915001	B3635	A3541
CATERPILLAR	365	EXC	SEALED	2.253	12.244	10.25	915139	B3607/8	A3541
CATERPILLAR	375	EXC	SEALED	2.253	12.244	10.25	915139	B3607/8	A3541
CATERPILLAR	561	PIPELAYER	SEALED	1.442	8.125	6.906	915009	B3635	A3541
CATERPILLAR	571		SEALED	1.752	9.875	7.984	915012	B3635	A3541
CATERPILLAR	572		SEALED	1.752	9.875	7.984	915012	B3635	A3541
CATERPILLAR	572		SEALED	1.877	9.88	8.5	915012	B3635	A3541
CATERPILLAR	578	PIPELAYER	SALT	1.88	9.88	8.5	915006	B3635	A3541
CATERPILLAR	578		PPR	1.878	9.65	8.5	A3326-001	B3635	A3541
CATERPILLAR	583		SEALED	1.752	11.438	7.985	915013	B3635	A3541
CATERPILLAR	589		PPR	2	10.77	9	A3326-002	B3635	A3541
CATERPILLAR	589	PIPELAYER	SALT	2	11.437	9	915093	B3635	A3541
CATERPILLAR	594		SEALED	2.252	12.25	10.25	915005	B3607/8	A3541
CATERPILLAR	931		SEALED	1.129	6.156	6.125	915004	A3536	A3539
CATERPILLAR	931		SALT	1.126	6.161	6.125	915082	A3536	A3539
CATERPILLAR	933		SEALED	1.129	6.156	6.125	915004	A3536	A3539
CATERPILLAR	939		SALT	1.318	7.535	6.735	915149	A3537	A3540
CATERPILLAR	941	w/ 5/8 BOLT	SEALED	1.314	7.22	6.735	915011	A3537	A3540

WTC Machinery
MPP 250 Tooling Chart

				Pin Dimensions				Disassembly Tools	
Make	Model	Comments	Type	Dia	Length	Pitch	PAT	Pin Tool	Back. Bush.
CATERPILLAR	941	w/ 9/16 BOLT	SEALED	1.314	7	6.735	915002	A3537	A3540
CATERPILLAR	941		SALT	1.314	7.22	6.735	915052	A3537	A3540
CATERPILLAR	943	HI RAIL	SALT	1.315	7.22	6.735	915002	A3537	A3540
CATERPILLAR	943	HI RAIL	SALT	1.314	7.22	6.735	915052	A3537	A3540
CATERPILLAR	951		SALT	1.442	8.12	6.906	915052	B3635	A3541
CATERPILLAR	951		SEALED	1.442	8.125	6.735	915009	B3635	A3541
CATERPILLAR	953	HI RAIL	SALT	1.442	8.12	6.906	915052	B3635	A3541
CATERPILLAR	953		SALT	1.442	8.12	6.906	915052	B3635	A3541
CATERPILLAR	953	LGP	SALT	1.442	8.12	6.906	915052	B3635	A3541
CATERPILLAR	955	HD	SEALED	1.442	8.125	6.735	915009	B3635	A3541
CATERPILLAR	955		SEALED	1.252	9.06	7.984	915003	A3537	A3540
CATERPILLAR	955		SALT	1.753	9.06	7.98	915003	B3635	A3541
CATERPILLAR	963		SALT	1.753	9.06	7.98	915003	B3635	A3541
CATERPILLAR	963	HI RAIL	SALT	1.753	9.06	7.98	915003	B3635	A3541
CATERPILLAR	973	HI RAIL	SALT	1.878	9.88	8.5	915201	B3635	A3541
CATERPILLAR	973		SALT	1.877	9.88	8.5	915006	B3635	A3541
CATERPILLAR	973	HI RAIL	SALT	1.877	9.88	8.5	915006	B3635	A3541
CATERPILLAR	973	LGP	SALT	1.877	9.88	8.5	915006	B3635	A3541
CATERPILLAR	973		SEALED	1.877	9.88	8.5	915012	B3635	A3541
CATERPILLAR	977	OPT FORMER	SEALED	1.442	8.125	6.906	915009	B3635	A3541
CATERPILLAR	977		SEALED	1.442	8.125	6.735	915009	B3635	A3541

WTC Machinery
MPP 250 Tooling Chart

				Pin Dimensions				Disassembly Tools	
Make	Model	Comments	Type	Dia	Length	Pitch	PAT	Pin Tool	Back. Bush.
CATERPILLAR	977		SALT	1.877	9.88	8.5	915006	B3635	A3541
CATERPILLAR	977		SEALED	1.877	9.88	8.5	915012	B3635	A3541
CATERPILLAR	983		SEALED	2.003	11.438	9	915001	B3635	A3541
CATERPILLAR	5080		SEALED	2.253	12.244	10.25	915139	B3607/8	A3541
CATERPILLAR	5130		SALT	2.626	14.173	12.5		B3631/3	A4157
CATERPILLAR			SEALED	1.488	8.582	7.48	915127	B3635	A3541
CATERPILLAR	E70B		SEALED	0.945	5.512	5.315	915129	A3536	A3539
CATERPILLAR	14A		SEALED	1.752	11.438	7.985	915013	B3635	A3541
CATERPILLAR	17A		SEALED	1.752	9.875	7.984	915012	B3635	A3541
CATERPILLAR	215A		SEALED	1.442	8.12	7.48	915052	B3635	A3541
CATERPILLAR	225B	EXC	SEALED	1.442	8.12	7.48	915052	B3635	A3541
CATERPILLAR	225C	EXC	SEALED	1.442	8.12	7.48	915052	B3635	A3541
CATERPILLAR	231D		SEALED	1.252	9.06	7.984	915003	A3537	A3540
CATERPILLAR	235D		SEALED	2.003	11.438	9	915001	B3635	A3541
CATERPILLAR	245S		SEALED	2.003	11.438	9	915001	B3635	A3541
CATERPILLAR	307C		GREASE	0.94	5.15	6.06	915169	A3536	A3539
CATERPILLAR	312C	EXC	GREASE	1.32	7	6.75	915059	A3537	A3540
CATERPILLAR	313B	EXC	SEALED	1.321	7.01	6.75	915059	A3537	A3540
CATERPILLAR	314B	EXC	SEALED	1.321	7.01	6.75	915059	A3537	A3540
CATERPILLAR	315B	EXC	GREASE	1.442	8.15	7.48	915236	B3635	A3541
CATERPILLAR	315C	EXC	GREASE	1.442	8.15	7.48	915170	B3635	A3541

WTC Machinery
MPP 250 Tooling Chart

				Pin Dimensions				Disassembly Tools	
Make	Model	Comments	Type	Dia	Length	Pitch	PAT	Pin Tool	Back. Bush.
CATERPILLAR	318C	EXC	GREASE	1.442	8.15	7.48	915170	B3635	A3541
CATERPILLAR	320B	EXC	SEALED	1.442	8.15	7.48	915140	B3635	A3541
CATERPILLAR	320C	EXC	GREASE	1.442	8.15	7.48	915170	B3635	A3541
CATERPILLAR	322B	EXC	GREASE	1.442	8.15	7.48	915236	B3635	A3541
CATERPILLAR	322C	EXC	GREASE	1.442	8.15	7.48	915170	B3635	A3541
CATERPILLAR	325BL	EXC	SEALED	1.654	9.055	8	915141	B3635	A3541
CATERPILLAR	325C	EXC	GREASE	1.65	9.05	7.985	915141	B3635	A3541
CATERPILLAR	330B	EXC	SEALED	1.811	9.665	8.5	915015	B3635	A3541
CATERPILLAR	330B	EXC	GREASE	1.811	9.665	8.5	915185	B3635	A3541
CATERPILLAR	330C	EXC	SEALED	1.811	9.665	8.5	915015	B3635	A3541
CATERPILLAR	345B	EXC	SALT	1.877	9.882	8.5	915200	B3635	A3541
CATERPILLAR	345B		SEALED	1.877	9.88	8.5	915012	B3635	A3541
CATERPILLAR	345BL	EXC	SALT	1.877	9.882	8.5	915200	B3635	A3541
CATERPILLAR	365BL	EXC	SEALED	2.253	12.244	10.25	915139	B3607/8	A3541
CATERPILLAR	385B	EXC	SEALED	2.253	13.188	10.25	915168	B3607/8	A3541
CATERPILLAR	561H	HD	SALT	1.418	8.445	6.735	915145	B3635	A3541
CATERPILLAR	561H		SALT	1.318	7.535	6.735	915149	A3537	A3540
CATERPILLAR	571A		SALT	1.877	9.88	8.5	915006	B3635	A3541
CATERPILLAR	571A		SEALED	1.877	9.88	8.5	915012	B3635	A3541
CATERPILLAR	583R	PIPELAYER	SALT	1.88	9.88	8.5	915006	B3635	A3541
CATERPILLAR	933	CURRENT	SALT	1.126	6.161	6.125	915082	A3536	A3539

WTC Machinery
MPP 250 Tooling Chart

				Pin Dimensions				Disassembly Tools	
Make	Model	Comments	Type	Dia	Length	Pitch	PAT	Pin Tool	Back. Bush.
CATERPILLAR	935B		SEALED	1.129	6.156	6.125	915004	A3536	A3539
CATERPILLAR	935B		SALT	1.126	6.161	6.125	915082	A3536	A3539
CATERPILLAR	935C		SALT	1.126	6.161	6.125	915082	A3536	A3539
CATERPILLAR	951B		SEALED	1.442	8.125	6.906	915009	B3635	A3541
CATERPILLAR	951B		SEALED	1.442	8.125	6.735	915009	B3635	A3541
CATERPILLAR	951C		SEALED	1.442	8.125	6.906	915009	B3635	A3541
CATERPILLAR	955K		SEALED	1.442	8.125	6.906	915009	B3635	A3541
CATERPILLAR	977K		SEALED	1.752	9.875	7.984	915012	B3635	A3541
CATERPILLAR	983		SALT	2.002	11.438	9	915007	B3635	A3541
CATERPILLAR	AP1050		SEALED	1.129	6.156	6.125	915004	A3536	A3539
CATERPILLAR	D10		PPR	2.252	11.974	10.25	915240	B3607/8	A3541
CATERPILLAR	D10		SALT	2.253	12.25	10.25	915063	B3607/8	A3541
CATERPILLAR	D10N		PPR	2.253	11.97	10.25	915246	B3607/8	A3541
CATERPILLAR	D10N		SALT	2.253	12.25	10.25	915104	B3607/8	A3541
CATERPILLAR	D10R		PPR	2.253	11.97	10.25	915246	B3607/8	A3541
CATERPILLAR	D10R		SALT	2.253	12.25	10.25	915104	B3607/8	A3541
CATERPILLAR	D10T		SALT	2.253	12.25	10.25	915104	B3607/8	A3541
CATERPILLAR	D11		SALT	2.626	13.81	12.5	915202	B3631/3	A4157
CATERPILLAR	D11N		PPR	2.252	11.97	12.5	915203	B3607/8	A3541
CATERPILLAR	D11R		PPR	2.252	11.97	12.5	915203	B3607/8	A3541
CATERPILLAR	D2		RECESS	1.127	6.156	6.125	916040	A3536	A3539

WTC Machinery
MPP 250 Tooling Chart

				Pin Dimensions				Disassembly Tools	
Make	Model	Comments	Type	Dia	Length	Pitch	PAT	Pin Tool	Back. Bush.
CATERPILLAR	D2		SEALED	1.125	6.18	6.125	915040	A3536	A3539
CATERPILLAR	D3		SEALED	1.129	6.156	6.125	915004	A3536	A3539
CATERPILLAR	D3		SALT	1.126	6.161	6.125	915082	A3536	A3539
CATERPILLAR	D3	EARLY	SALT	1.126	6.161	6.125	915082	A3536	A3539
CATERPILLAR	D3		SALT	1.126	6.161	6.125	915082	A3536	A3539
CATERPILLAR	D3	FORMER	SALT	1.126	6.161	6.125	915082	A3536	A3539
CATERPILLAR	D3B		SEALED	1.129	6.156	6.125	915004	A3536	A3539
CATERPILLAR	D3B		SALT	1.126	6.161	6.125	915082	A3536	A3539
CATERPILLAR	D3C		SALT	1.126	6.161	6.125	915082	A3536	A3539
CATERPILLAR	D3G		SEALED	1.129	6.156	6.125	915004	A3536	A3539
CATERPILLAR	D3G		SALT	1.126	6.161	6.125	915082	A3536	A3539
CATERPILLAR	D4		SEALED	1.314	7	6.735	915002	A3537	A3540
CATERPILLAR	D4		RECESS	1.314	7	6.735	915011	A3537	A3540
CATERPILLAR	D4	w/ 1/2 BOLT	SEALED	1.314	7	6.735	915137	A3537	A3540
CATERPILLAR	D4	w/ 9/16 BOLT	SEALED	1.314	7	6.735	915137	A3537	A3540
CATERPILLAR	D4	w/ 9/16 BOLT	SEALED	1.314	7	6.735	915138	A3537	A3540
CATERPILLAR	D4		SALT	1.314	7.22	6.735	915052	A3537	A3540
CATERPILLAR	D4B		SEALED	1.129	6.156	6.125	915004	A3536	A3539
CATERPILLAR	D4B		SALT	1.126	6.161	6.125	915082	A3536	A3539
CATERPILLAR	D4C		SEALED	1.129	6.156	6.125	915004	A3536	A3539
CATERPILLAR	D4C		SALT	1.126	6.161	6.125	915082	A3536	A3539

WTC Machinery
MPP 250 Tooling Chart

				Pin Dimensions				Disassembly Tools	
Make	Model	Comments	Type	Dia	Length	Pitch	PAT	Pin Tool	Back. Bush.
CATERPILLAR	D4C	w/ 1/2 BOLT	SEALED	1.314	7	6.735	915137	A3537	A3540
CATERPILLAR	D4C	w/ 9/16 BOLT	SEALED	1.314	7	6.735	915137	A3537	A3540
CATERPILLAR	D4C	w/ 9/16 BOLT	SEALED	1.314	7	6.735	915138	A3537	A3540
CATERPILLAR	D4D		SEALED	1.314	7.22	6.735	915011	A3537	A3540
CATERPILLAR	D4D		SEALED	1.314	7	6.735	915002	A3537	A3540
CATERPILLAR	D4D		SALT	1.314	7.22	6.735	915052	A3537	A3540
CATERPILLAR	D4D	w/ 1/2 BOLT	SEALED	1.314	7	6.735	915137	A3537	A3540
CATERPILLAR	D4D	w/ 9/16 BOLT	SEALED	1.314	7	6.735	915137	A3537	A3540
CATERPILLAR	D4D	w/ 9/16 BOLT	SEALED	1.314	7	6.735	915138	A3537	A3540
CATERPILLAR	D4E		SALT	1.314	7.22	6.735	915052	A3537	A3540
CATERPILLAR	D4G		SEALED	1.129	6.156	6.125	915004	A3536	A3539
CATERPILLAR	D4G		SALT	1.126	6.161	6.125	915082	A3536	A3539
CATERPILLAR	D4H		SALT	1.315	7.22	6.735	915124	A3537	A3540
CATERPILLAR	D4H	HD	SALT	1.418	8.445	6.735	915145	B3635	A3541
CATERPILLAR	D4H	LGP	PPR	1.315	7.287	6.735		A3537	A3540
CATERPILLAR	D4H		SALT	1.318	7.535	6.735	915149	A3537	A3540
CATERPILLAR	D4H	TSK CUS SKD	SALT	1.318	7.535	6.735	915149	A3537	A3540
CATERPILLAR	D5	PRO	SALT	1.442	8.12	6.906	915052	B3635	A3541
CATERPILLAR	D5		SALT	1.442	8.12	6.906	915018	B3635	A3541
CATERPILLAR	D5		SEALED	1.442	8.125	6.906	915009	B3635	A3541
CATERPILLAR	D5B		SEALED	1.442	8.125	6.906	915009	B3635	A3541

WTC Machinery
MPP 250 Tooling Chart

				Pin Dimensions				Disassembly Tools	
Make	Model	Comments	Type	Dia	Length	Pitch	PAT	Pin Tool	Back. Bush.
CATERPILLAR	D5B		SALT	1.442	8.12	6.906	915052	B3635	A3541
CATERPILLAR	D5C		SALT	1.318	7.535	6.735	915149	A3537	A3540
CATERPILLAR	D5G		SALT	1.318	7.535	6.735	915149	A3537	A3540
CATERPILLAR	D5G	XL	SALT	1.318	7.535	6.735	915149	A3537	A3540
CATERPILLAR	D5H		SALT	1.443	8.122	7.4803	915052	B3635	A3541
CATERPILLAR	D5H	TSK CUS SKD	SALT	1.443	8.183	7.4803	915052	B3635	A3541
CATERPILLAR	D5H	HD	SALT	1.495	9.392	7.48	915145	B3635	A3541
CATERPILLAR	D5M		SALT	1.418	8.445	6.735	915145	B3635	A3541
CATERPILLAR	D5N		SALT	1.418	8.445	6.735	915145	B3635	A3541
CATERPILLAR	D6		RECESS	1.442	8.125	6.735	915014	B3635	A3541
CATERPILLAR	D6		SALT	1.752	9.06	7.9845	915205	B3635	A3541
CATERPILLAR	D6		SEALED	1.442	8.125	6.735	915009	B3635	A3541
CATERPILLAR	D6B		SEALED	1.442	8.125	6.735	915009	B3635	A3541
CATERPILLAR	D6C		SEALED	1.252	9.06	7.984	915003	A3537	A3540
CATERPILLAR	D6C		SALT	1.753	9.06	7.98	915003	B3635	A3541
CATERPILLAR	D6D		SEALED	1.252	9.06	7.984	915003	A3537	A3540
CATERPILLAR	D6D		SALT	1.753	9.06	7.98	915003	B3635	A3541
CATERPILLAR	D6E		SALT	1.753	9.06	7.98	915003	B3635	A3541
CATERPILLAR	D6H	LGP	SALT	1.753	9.06	7.9846	915081	B3635	A3541
CATERPILLAR	D6H		SALT	1.753	9.06	7.9846	915081	B3635	A3541
CATERPILLAR	D6H	LGP	PPR	1.753	9.15	7.9846	915143	B3635	A3541

WTC Machinery
MPP 250 Tooling Chart

				Pin Dimensions				Disassembly Tools	
Make	Model	Comments	Type	Dia	Length	Pitch	PAT	Pin Tool	Back. Bush.
CATERPILLAR	D6H	HD	SALT	1.753	10.315	8	915143	B3635	A3541
CATERPILLAR	D6M		SALT	1.495	9.392	7.48	915145	B3635	A3541
CATERPILLAR	D6N		SALT	1.495	9.392	7.48	915145	B3635	A3541
CATERPILLAR	D6R		SALT	1.753	10.315	8	915081	B3635	A3541
CATERPILLAR	D7		SALT	1.877	9.88	8.5	915006	B3635	A3541
CATERPILLAR	D7		SEALED	1.752	9.875	7.984	915012	B3635	A3541
CATERPILLAR	D7		RECESS	1.752	9.875	7.985	915012	B3635	A3541
CATERPILLAR	D7C		SEALED	1.752	9.875	7.984	915012	B3635	A3541
CATERPILLAR	D7D		SEALED	1.752	9.875	7.984	915012	B3635	A3541
CATERPILLAR	D7D		RECESS	1.752	9.875	7.985	915012	B3635	A3541
CATERPILLAR	D7E		SALT	1.877	9.88	8.5	915006	B3635	A3541
CATERPILLAR	D7E		SEALED	1.877	9.88	8.5	915012	B3635	A3541
CATERPILLAR	D7F		SALT	1.877	9.88	8.5	915006	B3635	A3541
CATERPILLAR	D7F		SEALED	1.877	9.88	8.5	915012	B3635	A3541
CATERPILLAR	D7G		SALT	1.877	9.88	8.5	915006	B3635	A3541
CATERPILLAR	D7G	LGP	SALT	1.877	9.88	8.5	915006	B3635	A3541
CATERPILLAR	D7G		SEALED	1.877	9.88	8.5	915012	B3635	A3541
CATERPILLAR	D7H	LGP	PPR	1.878	9.925	8.5	915007	B3635	A3541
CATERPILLAR	D7H		SALT	1.878	9.88	8.5	915103	B3635	A3541
CATERPILLAR	D7H	HD	SALT	1.878	10.875	8.5	915150	B3635	A3541
CATERPILLAR	D7R		SALT	1.878	10.875	8.5	915150	B3635	A3541

WTC Machinery
MPP 250 Tooling Chart

				Pin Dimensions				Disassembly Tools	
Make	Model	Comments	Type	Dia	Length	Pitch	PAT	Pin Tool	Back. Bush.
CATERPILLAR	D8		RECESS	1.752	11.438	7.948	915206	B3635	A3541
CATERPILLAR	D8		SEALED	1.752	11.438	7.985	915013	B3635	A3541
CATERPILLAR	D8		SALT	2.002	11.438	9	915007	B3635	A3541
CATERPILLAR	D8D		SEALED	1.752	11.438	7.985	915013	B3635	A3541
CATERPILLAR	D8E		SEALED	1.752	11.438	7.985	915013	B3635	A3541
CATERPILLAR	D8F		SEALED	1.752	11.438	7.985	915013	B3635	A3541
CATERPILLAR	D8G		SEALED	1.752	11.438	7.985	915013	B3635	A3541
CATERPILLAR	D8H		SALT	2.002	11.438	9	915007	B3635	A3541
CATERPILLAR	D8H		SEALED	2.003	11.438	9	915001	B3635	A3541
CATERPILLAR	D8K		SALT	2.002	11.438	9	915007	B3635	A3541
CATERPILLAR	D8K		SEALED	2.003	11.438	9	915001	B3635	A3541
CATERPILLAR	D8L		SALT	1.88	9.88	8.5	915006	B3635	A3541
CATERPILLAR	D8N		SALT	1.88	9.88	8.5	915006	B3635	A3541
CATERPILLAR	D8N		PPR	1.878	9.65	8.5	N/A	B3635	A3541
CATERPILLAR	D8R		SALT	1.88	9.88	8.5	915006	B3635	A3541
CATERPILLAR	D8R		PPR	1.878	9.65	8.5	N/A	B3635	A3541
CATERPILLAR	D8T		SALT	1.88	9.88	8.5	915006	B3635	A3541
CATERPILLAR	D8T		SALT	1.878	9.65	8.5	N/A	B3635	A3541
CATERPILLAR	D9		SEALED	2.002	12	9	915208	B3635	A3541
CATERPILLAR	D9		SALT	2.252	12.25	10.25	915008	B3607/8	A3541
CATERPILLAR	D9D		SEALED	2.252	12.25	10.25	915005	B3607/8	A3541

WTC Machinery
MPP 250 Tooling Chart

				Pin Dimensions				Disassembly Tools	
Make	Model	Comments	Type	Dia	Length	Pitch	PAT	Pin Tool	Back. Bush.
CATERPILLAR	D9E		SEALED	2.252	12.25	10.25	915005	B3607/8	A3541
CATERPILLAR	D9G		SALT	2.252	12.25	10.25	915008	B3607/8	A3541
CATERPILLAR	D9G		SEALED	2.252	12.25	10.25	915005	B3607/8	A3541
CATERPILLAR	D9H		SALT	2.252	12.25	10.25	915008	B3607/8	A3541
CATERPILLAR	D9H		SEALED	2.252	12.25	10.25	915005	B3607/8	A3541
CATERPILLAR	D9L		PPR	2	10.77	9	N/A	B3635	A3541
CATERPILLAR	D9L		SALT	2	11.437	9	915093	B3635	A3541
CATERPILLAR	D9N		SALT	2.003	10.98	9.45	915092	B3635	A3541
CATERPILLAR	D9N		PPR	2	10.44	9.449	N/A	B3635	A3541
CATERPILLAR	D9R		SALT	2.003	10.98	9.45	915092	B3635	A3541
CATERPILLAR	D9R		PPR	2	10.44	9.449	N/A	B3635	A3541
CATERPILLAR	E110B		SEALED	1.319	7.008	6.75	915059	A3537	A3540
CATERPILLAR	E120B		SEALED	1.319	7.008	6.75	915059	A3537	A3540
CATERPILLAR	E180		SEALED	1.439	8.126	6.906	915128	B3635	A3541
CATERPILLAR	E200B		SEALED	1.445	8.15	7.5	915133	B3635	A3541
CATERPILLAR	E240		SEALED	1.445	8.15	7.5	915133	B3635	A3541
CATERPILLAR	E300B		SEALED	1.75	9.646	8	915121	B3635	A3541
CATERPILLAR	E450		UNSEALED	1.873	10	8.5	915038	B3635	A3541
CATERPILLAR	E70		SEALED	0.945	5.512	5.315	915129	A3536	A3539
CATERPILLAR	EL180		SEALED	1.439	8.126	6.906	915128	B3635	A3541
CATERPILLAR	EL200B		SEALED	1.445	8.15	7.5	915133	B3635	A3541

WTC Machinery
MPP 250 Tooling Chart

				Pin Dimensions				Disassembly Tools	
Make	Model	Comments	Type	Dia	Length	Pitch	PAT	Pin Tool	Back. Bush.
CATERPILLAR	EL240		SEALED	1.445	8.15	7.5	915133	B3635	A3541
CATERPILLAR	EL300A		SEALED	1.75	9.646	8	915121	B3635	A3541
CATERPILLAR	EL300B		SEALED	1.75	9.646	8	915121	B3635	A3541
CATERPILLAR	EL300B		SEALED	1.75	9.646	8	915038	B3635	A3541
CATERPILLAR	FB227		SEALED	1.252	9.06	7.984	915003	A3537	A3540
CATERPILLAR	MHI 180-8		SEALED	1.439	8.126	6.906	915128	B3635	A3541
CATERPILLAR	MHI 180-8LC		SEALED	1.439	8.126	6.906	915128	B3635	A3541
CATERPILLAR	MHI 300LC-8		SEALED	1.75	9.646	8	915121	B3635	A3541
CATERPILLAR	PR450		SEALED	1.129	6.156	6.125	915004	A3536	A3539
CATERPILLAR	R2-15-22		RECESS	1.127	6.156	6.125	916040	A3536	A3539
CATERPILLAR	R4		RECESS	1.314	7	6.735	915011	A3537	A3540
CATERPILLAR	SF350		SEALED	1.129	6.156	6.125	915004	A3536	A3539
CATERPILLAR	TR225		SEALED	1.129	6.156	6.125	915004	A3536	A3539
DRESSER	150		SEALED	1.375	6.69	6.49	915048	B3635	A3541
DRESSER	175		SEALED	1.625	7.87	6.992	915041	B3635	A3541
DRESSER	500		RECESSED	1.125	5.36	6	915044	A3536	A3539
DRESSER	100B		SEALED	1.25	5.97	6	915034	A3537	A3540
DRESSER	100C		SEALED	1.25	6.5	5.998	915040	A3537	A3540
DRESSER	100E		SEALED	1.25	6.5	5.99	915100	A3537	A3540
DRESSER	100G		SALT	1.312	6.69	6.49	915133	A3537	A3540
DRESSER	125C		SEALED	1.375	6.69	6.49	915048	B3635	A3541

WTC Machinery
MPP 250 Tooling Chart

				Pin Dimensions				Disassembly Tools	
Make	Model	Comments	Type	Dia	Length	Pitch	PAT	Pin Tool	Back. Bush.
DRESSER	125E		SEALED	1.375	6.69	6.49	915048	B3635	A3541
DRESSER	125G		SALT	1.312	6.69	6.49	915133	A3537	A3540
DRESSER	125G		SEALED	1.312	6.69	6.49	915040	A3537	A3540
DRESSER	125G		DRY	1.312	6.69	6.49	915213	A3537	A3540
DRESSER	175B		SEALED	1.625	7.87	6.992	915041	B3635	A3541
DRESSER	175B		SEALED	1.75	8.81	7.5	915036	B3635	A3541
DRESSER	175C		SEALED	1.75	8.81	7.5	915036	B3635	A3541
DRESSER	250B		SEALED	1.75	9.31	7.5	915036	B3635	A3541
DRESSER	250C		SEALED	1.75	9.31	7.5	915036	B3635	A3541
DRESSER	500E		DRY	1.125	5.3	5.99	915209	A3536	A3539
DRESSER	D32		SALT	1.312	6.69	6.49	915133	A3537	A3540
DRESSER	D32E		SEALED	1.25	6.5	5.998	915040	A3537	A3540
DRESSER	D32E		SALT	1.312	6.69	6.49	915133	A3537	A3540
DRESSER	D32P		SEALED	1.25	6.5	5.998	915040	A3537	A3540
DRESSER	D32-P1		SALT	1.312	6.69	6.49	915133	A3537	A3540
DRESSER	D38E		SALT	1.312	6.69	6.49	915133	A3537	A3540
DRESSER	D38P-1		SALT	1.312	6.69	6.49	915133	A3537	A3540
DRESSER	D38P-1		SALT	1.312	6.69	6.49	915133	A3537	A3540
DRESSER	D39		SALT	1.312	6.69	6.49	915133	A3537	A3540
DRESSER	D39E		SALT	1.312	6.69	6.49	915133	A3537	A3540
DRESSER	D87E-2		SALT	1.874	10.43	8.5	915077	B3635	A3541

WTC Machinery
MPP 250 Tooling Chart

				Pin Dimensions				Disassembly Tools	
Make	Model	Comments	Type	Dia	Length	Pitch	PAT	Pin Tool	Back. Bush.
DRESSER	D87P		SALT	1.874	10.43	8.5	915077	B3635	A3541
DRESSER	T340		FLUSH	1.01	4.75	6	915028	A3536	A3539
DRESSER	T5		FLUSH	1.01	4.75	6	915028	A3536	A3539
DRESSER	T6		SEALED	1.25	5.97	6	915034	A3537	A3540
DRESSER	T7		SEALED	1.25	6.5	5.998	915040	A3537	A3540
DRESSER	TD12		SALT	1.5	8.03	7.49	915095	B3635	A3541
DRESSER	TD12		SEALED	1.75	8.03	7.49	915095	B3635	A3541
DRESSER	TD12A		DRY	1.5	8.03	7.49	915210	B3635	A3541
DRESSER	TD12B		DRY	1.5	8.03	7.49	915210	B3635	A3541
DRESSER	TD12C		DRY	1.625	8.81	7.49	915211	B3635	A3541
DRESSER	TD12C-XP		SEALED	1.629	8.82	7.49	915083	B3635	A3541
DRESSER	TD14		SEALED	1.625	7.87	6.992	915041	B3635	A3541
DRESSER	TD15		SEALED	1.625	7.87	6.992	915041	B3635	A3541
DRESSER	TD15B		SEALED	1.625	7.87	6.992	915041	B3635	A3541
DRESSER	TD15B		SEALED	1.75	8.81	7.5	915036	B3635	A3541
DRESSER	TD15C		SEALED	1.75	8.81	7.5	915036	B3635	A3541
DRESSER	TD15C		SALT	1.625	8.81	7.49	915021	B3635	A3541
DRESSER	TD15C	LGP	SALT	1.625	8.81	7.49	915021	B3635	A3541
DRESSER	TD15C	SPLIT	SEALED	1.625	8.81	7.49	915021	B3635	A3541
DRESSER	TD15C	SPLIT	DRY	1.625	8.81	7.49	915211	B3635	A3541
DRESSER	TD15E		SEALED	1.75	8.81	7.98	915108	B3635	A3541

WTC Machinery
MPP 250 Tooling Chart

				Pin Dimensions				Disassembly Tools	
Make	Model	Comments	Type	Dia	Length	Pitch	PAT	Pin Tool	Back. Bush.
DRESSER	TD15E		SALT	1.75	8.81	7.98	915109	B3635	A3541
DRESSER	TD15E	LGP	SALT	1.75	8.81	7.98	915109	B3635	A3541
DRESSER	TD20B		SEALED	1.75	9.31	7.5	915036	B3635	A3541
DRESSER	TD20C		SEALED	1.75	9.31	7.5	915036	B3635	A3541
DRESSER	TD20C		SEALED	1.875	9.31	8.5	915035	B3635	A3541
DRESSER	TD20E		SALT	1.874	10.43	8.5	915077	B3635	A3541
DRESSER	TD20E		DRY	1.874	10.43	8.5	915212	B3635	A3541
DRESSER	TD20E		SEALED	1.875	10.44	8.5	915038	B3635	A3541
DRESSER	TD20E	SPLIT	SEALED	1.875	10.43	8.5	915077	B3635	A3541
DRESSER	TD20G		SALT	1.874	10.43	8.5	915077	B3635	A3541
DRESSER	TD20G	LGP	SALT	1.874	10.43	8.5	915077	B3635	A3541
DRESSER	TD20G		DRY	1.874	10.43	8.5	915212	B3635	A3541
DRESSER	TD24		SEALED	1.875	11	8.5	915037	B3635	A3541
DRESSER	TD25B		SEALED	1.875	11	8.5	915037	B3635	A3541
DRESSER	TD25C		SALT	2.125	11	9.87	915102	B3607/8	A3541
DRESSER	TD25C		SALT	2.125	11	9.86	915102	B3607/8	A3541
DRESSER	TD25C		SEALED	2.125	11	9.87	915102	B3607/8	A3541
DRESSER	TD25E		SALT	2.125	11	9.87	915102	B3607/8	A3541
DRESSER	TD25E		SALT	2.125	11	9.86	915102	B3607/8	A3541
DRESSER	TD25E		SEALED	2.125	11	9.87	915102	B3607/8	A3541
DRESSER	TD25E	SPLIT	SEALED	2.125	11	9.87	915102	B3607/8	A3541

WTC Machinery
MPP 250 Tooling Chart

				Pin Dimensions				Disassembly Tools	
Make	Model	Comments	Type	Dia	Length	Pitch	PAT	Pin Tool	Back. Bush.
DRESSER	TD25G		SALT	2.125	11	9.87	915102	B3607/8	A3541
DRESSER	TD25G		DRY	2.125	11	9.86	915102	B3607/8	A3541
DRESSER	TD30		SALT	2.125	11	9.86	915102	B3607/8	A3541
DRESSER	TD30		SEALED	2.125	11	9.87	915102	B3607/8	A3541
DRESSER	TD4		FLUSH	1.01	4.75	6	915028	A3536	A3539
DRESSER	TD40	SPLIT	SEALED	2.456	12.6	11.02	915101	B3607/8	A3541
DRESSER	TD40	SPLIT	SALT	2.456	12.6	11.02	915101	B3607/8	A3541
DRESSER	TD5		FLUSH	1.01	4.75	6	915028	A3536	A3539
DRESSER	TD6		SEALED	1.25	5.97	6	915034	A3537	A3540
DRESSER	TD7		SEALED	1.25	6.5	5.998	915040	A3537	A3540
DRESSER	TD7C		SEALED	1.25	6.5	5.998	915040	A3537	A3540
DRESSER	TD7E		SEALED	1.25	6.5	5.99	915100	A3537	A3540
DRESSER	TD7G		SALT	1.312	6.69	6.49	915133	A3537	A3540
DRESSER	TD7H		DRY	1.312	6.69	6.49	915213	A3537	A3540
DRESSER	TD8C		SEALED	1.375	6.69	6.49	915048	B3635	A3541
DRESSER	TD8E		SEALED	1.375	6.69	6.49	915048	B3635	A3541
DRESSER	TD8G		SALT	1.312	6.69	6.49	915133	A3537	A3540
DRESSER	TD8G		SEALED	1.312	6.69	6.49	915040	A3537	A3540
DRESSER	TD-8G		DRY	1.312	6.69	6.49	915213	A3537	A3540
DRESSER	TD9B		SEALED	1.375	6.69	6.49	915048	B3635	A3541
DRESSER	TD9H		SALT	1.312	6.69	6.49	915133	A3537	A3540

WTC Machinery
MPP 250 Tooling Chart

				Pin Dimensions				Disassembly Tools	
Make	Model	Comments	Type	Dia	Length	Pitch	PAT	Pin Tool	Back. Bush.
FIAT	31		SALT	2.374	12.953	11.281	915221	B3607/8	A3541
FIAT	31		DRY	2.374	12.953	11.281	915142	B3607/8	A3541
FIAT	652		UNSEALED	1.25	6.24	6	915004	A3537	A3540
FIAT	653		UNSEALED	1.25	6.24	6	915004	A3537	A3540
FIAT	655		UNSEALED	1.25	6.24	6	915004	A3537	A3540
FIAT	12G		SEALED	1.876	10.27	7.85	915020	B3635	A3541
FIAT	12G		UNSEALED	1.874	10.27	7.858	915020	B3635	A3541
FIAT	12GB		SEALED	1.878	10.27	7.858	915030	B3635	A3541
FIAT	14B		UNSEALED	1.578	8.661	7.48	915022	B3635	A3541
FIAT	41B		SALT	2.622	14	11.281	915218	B3631/3	A4157
FIAT	41B		DRY	2.622	14	11.281	915218	B3631/3	A4157
FIAT	AD10		UNSEALED	1.459	7.874	6.929	915022	B3635	A3541
FIAT	AD10B		UNSEALED	1.459	7.874	6.929	915022	B3635	A3541
FIAT	AD12		UNSEALED	1.578	8.661	7.48	915022	B3635	A3541
FIAT	AD12		SALT	1.577	8.66	6	915022	B3635	A3541
FIAT	AD14		UNSEALED	1.578	8.661	7.48	915022	B3635	A3541
FIAT	AD14		SALT	1.577	8.66	6	915022	B3635	A3541
FIAT	AD18		UNSEALED	1.87	9.84	8.503	915019	B3635	A3541
FIAT	AD20		UNSEALED	1.87	9.84	8.503	915019	B3635	A3541
FIAT	AD4		UNSEALED	0.984	5.28	5.512	915028	A3536	A3539
FIAT	AD5		UNSEALED	1.181	6.1	6.299	915027	A3536	A3539

WTC Machinery
MPP 250 Tooling Chart

				Pin Dimensions				Disassembly Tools	
Make	Model	Comments	Type	Dia	Length	Pitch	PAT	Pin Tool	Back. Bush.
FIAT	AD6		UNSEALED	1.377	7.01	6.692	915025	B3635	A3541
FIAT	AD7		UNSEALED	1.377	7.01	6.692	915025	B3635	A3541
FIAT	AD7C		UNSEALED	1.377	7.01	6.692	915025	B3635	A3541
FIAT	AD8		UNSEALED	1.38	7.126	6.693	915025	B3635	A3541
FIAT	AD9		UNSEALED	1.377	7.01	6.692	915025	B3635	A3541
FIAT	B1		UNSEALED	0.984	5.28	5.512	915028	A3536	A3539
FIAT	BD10		UNSEALED	1.459	7.874	6.929	915022	B3635	A3541
FIAT	BD10B		UNSEALED	1.459	7.874	6.929	915022	B3635	A3541
FIAT	BD12		UNSEALED	1.578	8.661	7.48	915022	B3635	A3541
FIAT	BD12		SALT	1.577	8.66	6	915022	B3635	A3541
FIAT	BD14		UNSEALED	1.578	8.661	7.48	915022	B3635	A3541
FIAT	BD14		SALT	1.577	8.66	6	915022	B3635	A3541
FIAT	BD18		UNSEALED	1.87	9.84	8.503	915019	B3635	A3541
FIAT	BD20		UNSEALED	1.87	9.84	8.503	915019	B3635	A3541
FIAT	BD7		UNSEALED	1.377	7.01	6.692	915025	B3635	A3541
FIAT	BD7C		UNSEALED	1.377	7.01	6.692	915025	B3635	A3541
FIAT	BD8		UNSEALED	1.38	7.126	6.693	915025	B3635	A3541
FIAT	BD9		UNSEALED	1.377	7.01	6.692	915025	B3635	A3541
FIAT	F318		SEALED	1.377	7.165	6.692	915154	B3635	A3541
FIAT	FA200		SALT	1.577	8.66	6	915022	B3635	A3541
FIAT	FD14		SALT	1.577	8.66	6	915022	B3635	A3541

WTC Machinery
MPP 250 Tooling Chart

				Pin Dimensions				Disassembly Tools	
Make	Model	Comments	Type	Dia	Length	Pitch	PAT	Pin Tool	Back. Bush.
FIAT	FD20		UNSEALED	1.873	9.843	8.504	915019	B3635	A3541
FIAT	FD20		SALT	1.88	9.9	8.503	915006	B3635	A3541
FIAT	FD30		UNSEALED	2.036	11.66	9.042	915016	B3635	A3541
FIAT	FD30		SALT	2.036	11.65	9.035	915105	B3635	A3541
FIAT	FD31		SEALED	2.373	12.95	11.25	915029	B3607/8	A3541
FIAT	FD31		UNSEALED	2.375	12.95	11.25	915073	B3607/8	A3541
FIAT	FD31		SALT	2.373	12.95	11.281	915094	B3607/8	A3541
FIAT	FD40		UNSEALED	2.375	12.95	11.25	915073	B3607/8	A3541
FIAT	FD40		SALT	2.373	12.95	11.281	915094	B3607/8	A3541
FIAT	FD40		SALT	2.374	12.953	11.281	915221	B3607/8	A3541
FIAT	FD40		DRY	2.374	12.953	11.281	915142	B3607/8	A3541
FIAT	FD40B		SALT	2.374	12.953	11.281	915221	B3607/8	A3541
FIAT	FD40B		DRY	2.374	12.953	11.281	915142	B3607/8	A3541
FIAT	FD5		UNSEALED	1.143	6.457	6.299	915120	A3536	A3539
FIAT	FD5		SALT	1.26	6.42	6.299	915130	A3537	A3540
FIAT	FD50		SALT	2.622	14	11.281	915218	B3631/3	A4157
FIAT	FD50		DRY	2.622	14	11.281	915218	B3631/3	A4157
FIAT	FD7		UNSEALED	1.143	6.457	6.299	915120	A3536	A3539
FIAT	FD7		SALT	1.26	6.42	6.299	915130	A3537	A3540
FIAT	FD9		UNSEALED	1.382	7.17	6.692	915014	B3635	A3541
FIAT	FD9		SALT	1.382	7.17	6.692	915014	B3635	A3541

WTC Machinery
MPP 250 Tooling Chart

				Pin Dimensions				Disassembly Tools	
Make	Model	Comments	Type	Dia	Length	Pitch	PAT	Pin Tool	Back. Bush.
FIAT	FE16		SEALED	1.377	7.165	6.692	915154	B3635	A3541
FIAT	FE20		SEALED	1.377	7.165	6.692	915154	B3635	A3541
FIAT	FE20LC		SEALED	1.377	7.165	6.692	915154	B3635	A3541
FIAT	FE8LC		SEALED	1.377	7.165	6.692	915154	B3635	A3541
FIAT	FH120		SEALED	1.377	7.165	6.692	915154	B3635	A3541
FIAT	FH150		SEALED	1.377	7.165	6.692	915154	B3635	A3541
FIAT	FH150LC		SEALED	1.377	7.165	6.692	915154	B3635	A3541
FIAT	FH200		SEALED	1.458	8.031	6.929	915118	B3635	A3541
FIAT	FH200LC		SEALED	1.458	8.031	6.929	915118	B3635	A3541
FIAT	FL10		UNSEALED	1.459	7.874	6.929	915022	B3635	A3541
FIAT	FL10B		UNSEALED	1.459	7.874	6.929	915022	B3635	A3541
FIAT	FL12		UNSEALED	1.578	8.661	7.48	915022	B3635	A3541
FIAT	FL14		UNSEALED	1.578	8.661	7.48	915022	B3635	A3541
FIAT	FL14		SALT	1.577	8.66	6	915022	B3635	A3541
FIAT	FL14B		UNSEALED	1.578	8.661	7.48	915022	B3635	A3541
FIAT	FL14C		UNSEALED	1.578	8.661	7.48	915022	B3635	A3541
FIAT	FL14D		SALT	1.577	8.66	6	915022	B3635	A3541
FIAT	FL14E		SALT	1.577	8.66	6	915022	B3635	A3541
FIAT	FL20	S/N 7607 & DN	UNSEALED	1.873	9.843	8.504	915019	B3635	A3541
FIAT	FL20	7608 & UP	SALT	1.88	9.9	8.503	915006	B3635	A3541
FIAT	FL4AC		UNSEALED	0.984	5.28	5.512	915028	A3536	A3539

WTC Machinery
MPP 250 Tooling Chart

				Pin Dimensions				Disassembly Tools	
Make	Model	Comments	Type	Dia	Length	Pitch	PAT	Pin Tool	Back. Bush.
FIAT	FL4AD		UNSEALED	0.984	5.28	5.512	915028	A3536	A3539
FIAT	FL4L		UNSEALED	0.984	5.28	5.512	915028	A3536	A3539
FIAT	FL5		UNSEALED	1.143	6.457	6.299	915120	A3536	A3539
FIAT	FL5		SALT	1.26	6.42	6.299	915130	A3537	A3540
FIAT	FL5B		SALT	1.26	6.42	6.299	915130	A3537	A3540
FIAT	FL6		UNSEALED	1.181	6.1	6.299	915027	A3536	A3539
FIAT	FL7		UNSEALED	1.143	6.457	6.299	915120	A3536	A3539
FIAT	FL7		SALT	1.26	6.42	6.299	915130	A3537	A3540
FIAT	FL7		UNSEALED	1.377	7.01	6.692	915025	B3635	A3541
FIAT	FL7B		SALT	1.26	6.42	6.299	915130	A3537	A3540
FIAT	FL8		UNSEALED	1.377	7.01	6.692	915025	B3635	A3541
FIAT	FL8C		UNSEALED	1.377	7.01	6.692	915025	B3635	A3541
FIAT	FL9		UNSEALED	1.38	7.126	6.693	915025	B3635	A3541
FIAT	FP120	S/N 41-3000	SALT	2.374	12.953	11.281	915221	B3607/8	A3541
FIAT	FP120	S/N 41-3000	DRY	2.374	12.953	11.281	915142	B3607/8	A3541
FIAT	GH11E	S/N 10000 & DN	UNSEALED	1.565	8.14	7	915214	B3635	A3541
FIAT	H3			1.253	5.84	6	915219	A3537	A3540
FIAT	H4		UNSEALED	1.25	6.24	6	915004	A3537	A3540
FIAT	H4			1.253	5.84	6	915219	A3537	A3540
FIAT	HD10			1.753	8.37	7.85	915220	B3635	A3541
FIAT	HD11	S/N 7538-10000	SEALED	1.562	8.14	7	915031	B3635	A3541

WTC Machinery
MPP 250 Tooling Chart

				Pin Dimensions				Disassembly Tools	
Make	Model	Comments	Type	Dia	Length	Pitch	PAT	Pin Tool	Back. Bush.
FIAT	HD11	SN 5901 & UP	SEALED	1.62	8.4	7.006	915024	B3635	A3541
FIAT	HD11	S/N 10001 & UP	UNSEALED	1.62	8.4	7.006	915024	B3635	A3541
FIAT	HD11	S/N 1000 & DN	UNSEALED	1.565	8.14	7.006	915023	B3635	A3541
FIAT	HD11B		SEALED	1.62	8.4	7.006	915024	B3635	A3541
FIAT	HD11B	S/N 10001-19484	UNSEALED	1.62	8.4	7.006	915024	B3635	A3541
FIAT	HD11B	S/N 19485 & UP	UNSEALED	1.62	8.6	7.006	915215	B3635	A3541
FIAT	HD11E	S/N 10000 & DN	SEALED	1.565	8.14	7.006	915023	B3635	A3541
FIAT	HD11G	S/N 8940 & DN	SEALED	1.565	8.14	7.006	915023	B3635	A3541
FIAT	HD11G	S/N 8940 & DN	UNSEALED	1.565	8.14	7	915214	B3635	A3541
FIAT	HD11G	S/N 8940 & UP	UNSEALED	1.565	8.14	7.006	915023	B3635	A3541
FIAT	HD14			1.878	9.67	7.85	915216	B3635	A3541
FIAT	HD14			1.875	9.67	7.85	915020	B3635	A3541
FIAT	HD15		UNSEALED	1.753	9.33	7.858	915021	B3635	A3541
FIAT	HD16	S/N 5901 & UP	SEALED	1.876	10.27	7.85	915020	B3635	A3541
FIAT	HD16	S/N 5900 & DN	UNSEALED	1.753	9.33	7.858	915021	B3635	A3541
FIAT	HD16	S/N 5901 & UP	UNSEALED	1.874	10.27	7.858	915020	B3635	A3541
FIAT	HD16B		SEALED	1.878	10.27	7.858	915030	B3635	A3541
FIAT	HD19		SEALED	1.878	11.66	9.008	915017	B3635	A3541
FIAT	HD19		UNSEALED	1.876	11.66	9	915217	B3635	A3541
FIAT	HD19		SEALED	1.876	11.66	9	915017	B3635	A3541
FIAT	HD20		SEALED	1.878	11.66	9.008	915017	B3635	A3541

WTC Machinery
MPP 250 Tooling Chart

				Pin Dimensions				Disassembly Tools	
Make	Model	Comments	Type	Dia	Length	Pitch	PAT	Pin Tool	Back. Bush.
FIAT	HD20		UNSEALED	1.876	11.66	9	915217	B3635	A3541
FIAT	HD20		SEALED	1.876	11.66	9	915017	B3635	A3541
FIAT	HD21	S/N 13871-14942	SEALED	1.878	11.66	9.008	915017	B3635	A3541
FIAT	HD21		UNSEALED	1.878	11.66	9.008	915017	B3635	A3541
FIAT	HD21	S/N14943 & UP	SEALED	1.878	11.66	9.008	915017	B3635	A3541
FIAT	HD21	S/N 14942 & DN	UNSEALED	1.878	11.66	9.008	915221	B3635	A3541
FIAT	HD21B		SEALED	1.876	11.66	9	915016	B3635	A3541
FIAT	HD21B		UNSEALED	1.876	11.66	9	915018	B3635	A3541
FIAT	HD21C		UNSEALED	2.036	11.66	9.042	915016	B3635	A3541
FIAT	HD21P	S/N 14942 & DN	UNSEALED	1.876	11.66	9	915217	B3635	A3541
FIAT	HD21P	S/N 14942 & DN	SEALED	1.876	11.66	9	915017	B3635	A3541
FIAT	HD21P	S/N 14943 & UP	UNSEALED	1.878	11.66	9.008	915017	B3635	A3541
FIAT	HD3			1.253	5.84	6	915219	A3537	A3540
FIAT	HD31		UNSEALED	2.375	12.95	11.25	915073	B3607/8	A3541
FIAT	HD31		SALT	2.373	12.95	11.281	915094	B3607/8	A3541
FIAT	HD4	S/N 3001 & UP	UNSEALED	1.25	6.24	6	915004	A3537	A3540
FIAT	HD4			1.253	5.84	6	915219	A3537	A3540
FIAT	HD41		SEALED	2.373	12.95	11.25	915029	B3607/8	A3541
FIAT	HD41		UNSEALED	2.375	12.95	11.25	915073	B3607/8	A3541
FIAT	HD41		SALT	2.373	12.95	11.281	915094	B3607/8	A3541
FIAT	HD41B		UNSEALED	2.623	14	11.28	915033	B3631/3	A4157

WTC Machinery
MPP 250 Tooling Chart

				Pin Dimensions				Disassembly Tools	
Make	Model	Comments	Type	Dia	Length	Pitch	PAT	Pin Tool	Back. Bush.
FIAT	HD41B		SALT	2.622	14	11.28	915218	B3631/3	A4157
FIAT	HD5		SEALED	1.375	6.91	6.495	915014	B3635	A3541
FIAT	HD5		UNSEALED	1.375	6.91	6.495	915014	B3635	A3541
FIAT	HD5			1.753	8.37	7.85	915220	B3635	A3541
FIAT	HD50		UNSEALED	2.623	14	11.28	915033	B3631/3	A4157
FIAT	HD50		SALT	2.622	14	11.28	915218	B3631/3	A4157
FIAT	HD50			1.753	8.37	7.85	915220	B3635	A3541
FIAT	HD6		SEALED	1.375	6.91	6.495	915014	B3635	A3541
FIAT	HD6		UNSEALED	1.375	6.91	6.495	915014	B3635	A3541
FIAT	HD7	S/N 1102 & DN	UNSEALED	1.738	7.51	6.5	915026	B3635	A3541
FIAT	HD7	S/N 1103 & UP	UNSEALED	1.565	8.14	6.5	915023	B3635	A3541
FIAT	HD7G		SEALED	1.565	8.14	7.006	915023	B3635	A3541
FIAT	HD7G		UNSEALED	1.565	8.14	7	915214	B3635	A3541
FIAT	HD7G		UNSEALED	1.565	8.14	7.006	915023	B3635	A3541
FIAT	HD7G-B		SEALED	1.562	8.14	7	915031	B3635	A3541
FIAT	HD9		SEALED	1.565	8.14	7.006	915023	B3635	A3541
FIAT	HD9		UNSEALED	1.565	8.14	7	915214	B3635	A3541
FIAT	HD9		UNSEALED	1.565	8.14	7.006	915023	B3635	A3541
FIAT	K		UNSEALED	1.738	7.51	6.5	915026	B3635	A3541
FIAT	KO		UNSEALED	1.738	7.51	6.5	915026	B3635	A3541
FIAT	PH130		SEALED	1.377	7.165	6.692	915154	B3635	A3541

WTC Machinery
MPP 250 Tooling Chart

				Pin Dimensions				Disassembly Tools	
Make	Model	Comments	Type	Dia	Length	Pitch	PAT	Pin Tool	Back. Bush.
FIAT	S11		SEALED	1.377	7.165	6.692	915154	B3635	A3541
FIAT	S9		SEALED	1.377	7.165	6.692	915154	B3635	A3541
FIAT	SL11	33/281 & UP	SEALED	1.377	7.165	6.692	915154	B3635	A3541
FIAT	SL9	30/241 & UP	SEALED	1.377	7.165	6.692	915154	B3635	A3541
HITACHI	EX100		UNSEALED	1.315	7.283	6.736	915223	A3537	A3540
HITACHI	EX1100		SEALED	2.29	12.578	10.25	915171	B3607/8	A3541
HITACHI	EX120		UNSEALED	1.315	7.283	6.736	915223	A3537	A3540
HITACHI	EX1200-5		SEALED	2.29	12.578	10.25	915171	B3607/8	A3541
HITACHI	EX150		SEALED	1.378	7.598	6.75	915002	B3635	A3541
HITACHI	EX1800		SEALED	2.756	14.45	12.5	915107	B3605/6	A4157
HITACHI	EX200		SEALED	1.442	8.346	7.484	915134	B3635	A3541
HITACHI	EX220		SEALED	1.496	8.346	7.48	915042	B3635	A3541
HITACHI	EX300		SEALED	1.75	9.65	8	915121	B3635	A3541
HITACHI	EX400		SEALED	1.875	10	8.5	915012	B3635	A3541
HITACHI	EX550		SEALED	1.909	11.57	9	915087	B3635	A3541
HITACHI	EX700		SEALED	2.185	12.61	10.25	915125	B3607/8	A3541
HITACHI	EX800		SEALED	2.185	12.61	10.25	915125	B3607/8	A3541
HITACHI	EX90		UNSEALED	1.315	7.283	6.736	915223	A3537	A3540
HITACHI	UH083		SALT	1.44	8.11	6.909	915042	B3635	A3541
HITACHI	UH801		SALT	2.756	14.37	12.5	915090	B3605/6	A4157
HITACHI	ZX350		SEALED	1.75	9.65	8	915121	B3635	A3541

WTC Machinery
MPP 250 Tooling Chart

				Pin Dimensions				Disassembly Tools	
Make	Model	Comments	Type	Dia	Length	Pitch	PAT	Pin Tool	Back. Bush.
JOHN DEERE	50		SEALED	0.867	4.84	5.315	915027	A3536	A3539
JOHN DEERE	70		SEALED	1.19	6.102	6.063	915025	A3536	A3539
JOHN DEERE	80		SEALED	0.95	5.157	6.062	915074	A3536	A3539
JOHN DEERE	110		SEALED	1.319	7.008	6.75	915002	A3537	A3540
JOHN DEERE	120		SEALED	1.319	7.008	6.75	915002	A3537	A3540
JOHN DEERE	135		SEALED	1.319	7.008	6.75	915002	A3537	A3540
JOHN DEERE	350		FLUSH	1.192	5.47	5.7485	915065	A3536	A3539
JOHN DEERE	370		SEALED	1.873	10	8.5	915087	B3635	A3541
JOHN DEERE	440		FLUSH	1.004	5.46875	5.7485	915064	A3536	A3539
JOHN DEERE	450		FLUSH	1.3765	6.08	6.29	915056	B3635	A3541
JOHN DEERE	450		RECESSED	1.376	6.08	6.29	915056	B3635	A3541
JOHN DEERE	490		RECESSED	1.32	6.97	6.75	915074	A3537	A3540
JOHN DEERE	550		SEALED	1.376	6.2	6.29	915074	B3635	A3541
JOHN DEERE	555		SEALED	1.376	6.2	6.29	915074	B3635	A3541
JOHN DEERE	590	S/N 001787 & UP		1.366	7.598	6.75	915228	A3537	A3540
JOHN DEERE	655		SEALED	1.44	8.11	6.909	915042	B3635	A3541
JOHN DEERE	655		SALT	1.44	8.11	6.9909	915042	B3635	A3541
JOHN DEERE	700		SALT	1.44	8.11	6.9909	915042	B3635	A3541
JOHN DEERE	750		SEALED	1.44	8.11	6.909	915042	B3635	A3541
JOHN DEERE	750		SALT	1.44	8.11	6.9909	915042	B3635	A3541
JOHN DEERE	755		SEALED	1.44	8.11	6.909	915042	B3635	A3541

WTC Machinery
MPP 250 Tooling Chart

				Pin Dimensions				Disassembly Tools	
Make	Model	Comments	Type	Dia	Length	Pitch	PAT	Pin Tool	Back. Bush.
JOHN DEERE	755		SALT	1.44	8.11	6.9909	915042	B3635	A3541
JOHN DEERE	790		SEALED	1.496	8.58	7.48	915022	B3635	A3541
JOHN DEERE	792		SEALED	1.75	9.646	8	915121	B3635	A3541
JOHN DEERE	850		SEALED	1.75	9.06	8	915013	B3635	A3541
JOHN DEERE	855		SEALED	1.878	9.902	8.5	915083	B3635	A3541
JOHN DEERE	855		SALT	1.881	9.882	8.5	915006	B3635	A3541
JOHN DEERE	890		SEALED	1.878	9.902	8.5	915083	B3635	A3541
JOHN DEERE	890		RECESSED	1.88	9.9	8.5	915227	B3635	A3541
JOHN DEERE	990		SEALED	1.878	9.902	8.5	915083	B3635	A3541
JOHN DEERE	1280	EXC		1.439	8.11	6.9	915229	B3635	A3541
JOHN DEERE	2010	S/N 42001 & UP	FLUSH	1.192	5.47	5.7485	915065	A3536	A3539
JOHN DEERE	2010	S/N 42000 & DN	FLUSH	1.004	5.46875	5.7485	915064	A3536	A3539
JOHN DEERE	1050C			2	10.31	8.5	915172	B3635	A3541
JOHN DEERE	1050J			2	10.31	8.5	915172	B3635	A3541
JOHN DEERE	1150D		SALT	1.44	8.11	6.678	915215	B3635	A3541
JOHN DEERE	1155D		SALT	1.44	8.11	6.678	915215	B3635	A3541
JOHN DEERE	120 EXC		SEALED	1.3	7.24	6.96	915059	A3537	A3540
JOHN DEERE	120C		SEALED	1.319	7.008	6.75	915002	A3537	A3540
JOHN DEERE	160LC		SEALED	1.493	8.366	7.48	915042	B3635	A3541
JOHN DEERE	190E		SEALED	1.19	6.102	6.063	915025	A3536	A3539
JOHN DEERE	190E			1.19	6.102	6.063	915230	A3536	A3539

WTC Machinery
MPP 250 Tooling Chart

				Pin Dimensions				Disassembly Tools	
Make	Model	Comments	Type	Dia	Length	Pitch	PAT	Pin Tool	Back. Bush.
JOHN DEERE	200LC		SEALED	1.493	8.366	7.48	915042	B3635	A3541
JOHN DEERE	230		SEALED	1.493	8.366	7.48	915042	B3635	A3541
JOHN DEERE	230CLC		SEALED	1.496	8.583	7.48	915023	B3635	A3541
JOHN DEERE	230LC		SEALED	1.496	8.583	7.48	915023	B3635	A3541
JOHN DEERE	230LC		SEALED	1.493	8.366	7.48	915042	B3635	A3541
JOHN DEERE	240D		SEALED	1.496	8.583	7.48	915023	B3635	A3541
JOHN DEERE	270CLC		SEALED	1.76	9.52	8.5	915162	B3635	A3541
JOHN DEERE	270LC		SEALED	1.75	9.646	8	915121	B3635	A3541
JOHN DEERE	290D		SEALED	1.181	6.456	6.125	915136	A3536	A3539
JOHN DEERE	291		SEALED	1.181	6.456	6.125	915136	A3536	A3539
JOHN DEERE	330CLC		SEALED	1.76	9.52	8.5	915162	B3635	A3541
JOHN DEERE	330LC	EXC	SEALED	1.76	9.52	8.5	915162	B3635	A3541
JOHN DEERE	350B		FLUSH	1.192	5.47	5.7485	915065	A3536	A3539
JOHN DEERE	350C		FLUSH	1.192	5.47	5.7485	915065	A3536	A3539
JOHN DEERE	350D		SEALED	1.192	5.38	5.749	915027	A3536	A3539
JOHN DEERE	400G		SEALED	1.192	5.38	5.749	915027	A3536	A3539
JOHN DEERE	420C		FLUSH	1.004	5.46875	5.7485	915064	A3536	A3539
JOHN DEERE	450B		RECESSED	1.376	6.08	6.29	915056	B3635	A3541
JOHN DEERE	450C	S/N 216337 & DN	RECESSED	1.376	6.08	6.29	915056	B3635	A3541
JOHN DEERE	450C		SALT	1.256	6.378	6.29	915014	A3537	A3540
JOHN DEERE	450C	S/N 216338 & UP	SEALED	1.376	6.2	6.29	915074	B3635	A3541

WTC Machinery
MPP 250 Tooling Chart

				Pin Dimensions				Disassembly Tools	
Make	Model	Comments	Type	Dia	Length	Pitch	PAT	Pin Tool	Back. Bush.
JOHN DEERE	450CLC		SEALED	1.873	10	8.5	915087	B3635	A3541
JOHN DEERE	450D		SEALED	1.259	6.358	6.29	915046	A3537	A3540
JOHN DEERE	450D		SALT	1.256	6.378	6.29	915014	A3537	A3540
JOHN DEERE	450E		SEALED	1.259	6.358	6.29	915046	A3537	A3540
JOHN DEERE	450G		SEALED	1.259	6.358	6.29	915046	A3537	A3540
JOHN DEERE	450G		SALT	1.256	6.378	6.29	915014	A3537	A3540
JOHN DEERE	450H		SEALED	1.259	6.358	6.29	915046	A3537	A3540
JOHN DEERE	450H		SALT	1.256	6.378	6.29	915014	A3537	A3540
JOHN DEERE	450J		SEALED	1.259	6.358	6.29	915046	A3537	A3540
JOHN DEERE	450J		SALT	1.256	6.378	6.29	915014	A3537	A3540
JOHN DEERE	450LC		SEALED	1.873	10	8.5	915087	B3635	A3541
JOHN DEERE	455D		SEALED	1.259	6.358	6.29	915046	A3537	A3540
JOHN DEERE	455G		SEALED	1.259	6.358	6.29	915046	A3537	A3540
JOHN DEERE	455G		SALT	1.256	6.378	6.29	915014	A3537	A3540
JOHN DEERE	490D		SEALED	1.319	7.008	6.75	915002	A3537	A3540
JOHN DEERE	490E		SEALED	1.33	6.7	6.73	915166	A3537	A3540
JOHN DEERE	550A		SEALED	1.259	6.358	6.29	915046	A3537	A3540
JOHN DEERE	550A		SALT	1.256	6.378	6.29	915014	A3537	A3540
JOHN DEERE	550B		SEALED	1.259	6.358	6.29	915046	A3537	A3540
JOHN DEERE	550B		SALT	1.256	6.378	6.29	915014	A3537	A3540
JOHN DEERE	550G		SALT	1.256	6.378	6.29	915014	A3537	A3540

WTC Machinery
MPP 250 Tooling Chart

				Pin Dimensions				Disassembly Tools	
Make	Model	Comments	Type	Dia	Length	Pitch	PAT	Pin Tool	Back. Bush.
JOHN DEERE	550G		SEALED	1.259	6.358	6.29	915046	A3537	A3540
JOHN DEERE	550H		SEALED	1.259	6.358	6.29	915046	A3537	A3540
JOHN DEERE	550H		SALT	1.256	6.378	6.29	915014	A3537	A3540
JOHN DEERE	550J		SALT	1.256	6.378	6.29	915014	A3537	A3540
JOHN DEERE	555G		SALT	1.31	7.24	6.734	915089	A3537	A3540
JOHN DEERE	555G		SEALED	1.318	7.224	6.29	915089	A3537	A3540
JOHN DEERE	590D		SEALED	1.378	7.598	6.75	915002	B3635	A3541
JOHN DEERE	590D	S/N 1787 & UP	SEALED	1.366	7.598	6.75	915142	A3537	A3540
JOHN DEERE	650G		SALT	1.31	7.24	6.734	915089	A3537	A3540
JOHN DEERE	650G		SEALED	1.318	7.224	6.29	915089	A3537	A3540
JOHN DEERE	650H		SALT	1.31	7.24	6.734	915089	A3537	A3540
JOHN DEERE	650H		SEALED	1.318	7.224	6.29	915089	A3537	A3540
JOHN DEERE	650J		SALT	1.31	7.24	6.734	915089	A3537	A3540
JOHN DEERE	650J		SEALED	1.318	7.224	6.29	915089	A3537	A3540
JOHN DEERE	655B		SALT	1.44	8.11	6.9909	915042	B3635	A3541
JOHN DEERE	690A		RECESSED	1.32	6.97	6.75	915074	A3537	A3540
JOHN DEERE	690B		RECESSED	1.32	6.97	6.75	915074	A3537	A3540
JOHN DEERE	690C		RECESSED	1.32	6.97	6.75	915074	A3537	A3540
JOHN DEERE	690D		RECESSED	1.32	6.97	6.75	915074	A3537	A3540
JOHN DEERE	690E		SEALED	1.437	8.15	7.48	915079	B3635	A3541
JOHN DEERE	690ELC		SEALED	1.437	8.15	7.48	915079	B3635	A3541

WTC Machinery
MPP 250 Tooling Chart

				Pin Dimensions				Disassembly Tools	
Make	Model	Comments	Type	Dia	Length	Pitch	PAT	Pin Tool	Back. Bush.
JOHN DEERE	693B		RECESSED	1.32	6.97	6.75	915074	A3537	A3540
JOHN DEERE	693D		SEALED	1.44	8.11	6.909	915042	B3635	A3541
JOHN DEERE	700J		SALT	1.44	8.11	6.9909	915042	B3635	A3541
JOHN DEERE	70D		SEALED	1.19	6.102	6.063	915025	A3536	A3539
JOHN DEERE	750B		SEALED	1.44	8.11	6.909	915042	B3635	A3541
JOHN DEERE	750B		SALT	1.44	8.11	6.9909	915042	B3635	A3541
JOHN DEERE	750C		SALT	1.437	8.125	7.48	915052	B3635	A3541
JOHN DEERE	750J		SALT	1.496	9.39	7.48	915080	B3635	A3541
JOHN DEERE	755A		SEALED	1.753	9.13	7.984	915099	B3635	A3541
JOHN DEERE	755B		SEALED	1.44	8.11	6.909	915042	B3635	A3541
JOHN DEERE	755C		SALT	1.753	9.06	7.984	915106	B3635	A3541
JOHN DEERE	755C		SEALED	1.75	9.06	8	915013	B3635	A3541
JOHN DEERE	790D		SEALED	1.496	8.583	7.48	915023	B3635	A3541
JOHN DEERE	790E		SEALED	1.493	8.366	7.48	915042	B3635	A3541
JOHN DEERE	790ELC		SEALED	1.493	8.366	7.48	915042	B3635	A3541
JOHN DEERE	792D		SEALED	1.75	9.646	8	915121	B3635	A3541
JOHN DEERE	80C		SEALED	0.95	5.157	6.062	915074	A3536	A3539
JOHN DEERE	850B		SALT	1.753	9.06	7.984	915106	B3635	A3541
JOHN DEERE	850B		SEALED	1.753	9.13	7.984	915099	B3635	A3541
JOHN DEERE	850C		SALT	1.753	9.06	7.984	915106	B3635	A3541
JOHN DEERE	850C		SEALED	1.75	9.06	8	915013	B3635	A3541

WTC Machinery
MPP 250 Tooling Chart

				Pin Dimensions				Disassembly Tools	
Make	Model	Comments	Type	Dia	Length	Pitch	PAT	Pin Tool	Back. Bush.
JOHN DEERE	850J		SALT	1.75	10.315	8	915175	B3635	A3541
JOHN DEERE	890A		SEALED	1.878	9.902	8.5	915083	B3635	A3541
JOHN DEERE	892D		SEALED	1.75	9.646	8	915121	B3635	A3541
JOHN DEERE	892E		SEALED	1.75	9.646	8	915121	B3635	A3541
JOHN DEERE	950J		SALT	1.87	10.86	8.5	915189	B3635	A3541
JOHN DEERE	992D		SEALED	1.873	10	8.5	915087	B3635	A3541
JOHN DEERE	992E		SEALED	1.873	10	8.5	915087	B3635	A3541
JOHN DEERE	EX120		SEALED	1.319	7.008	6.75	915002	A3537	A3540
JOHN DEERE	EX120-2		SEALED	1.33	6.7	6.73	915166	A3537	A3540
JOHN DEERE	EX150		SEALED	1.378	7.598	6.75	915002	B3635	A3541
JOHN DEERE	JD700		SEALED	1.44	8.11	6.909	915042	B3635	A3541
JOHN DEERE	JD700HLGP		SEALED	1.44	8.11	6.909	915042	B3635	A3541
JOHN DEERE	JD700HLGP		SALT	1.44	8.11	6.9909	915042	B3635	A3541
KOBELCO	K909A		UNSEALED	1.496	8.58	7.48	915023	B3635	A3541
KOMATSU	D455A-1	S/N 1090-1333	SALT	2.76	14.37	12.5	915090	B3605/6	A4157
KOMATSU	EX1800-PC1800	133 mm	SALT	2.76	13.78	12.51	915107	B3605/6	A4157
KOMATSU	D120-15		SEALED	1.988	11.3	9	915055	B3635	A3541
KOMATSU	D120-18		SEALED	1.988	11.3	9	915055	B3635	A3541
KOMATSU	D120-8		SEALED	1.988	11.3	9	915055	B3635	A3541
KOMATSU	D125-18		RECESSED	1.988	11.3	9	915206	B3635	A3541
KOMATSU	D135A-1			1.909	11.575	9		B3635	A3541

WTC Machinery
MPP 250 Tooling Chart

				Pin Dimensions				Disassembly Tools	
Make	Model	Comments	Type	Dia	Length	Pitch	PAT	Pin Tool	Back. Bush.
KOMATSU	D150-1	S/N 6842 & DN	SEALED	1.988	11.3	9	915055	B3635	A3541
KOMATSU	D150-1	S/N 6843 & UP	SEALED	1.929	11.54	9	915086	B3635	A3541
KOMATSU	D150-1		SALT	1.909	11.57	9	915055	B3635	A3541
KOMATSU	D150-1	S/N 6842 & DN	UNSEALED	1.988	11.299	9	915055	B3635	A3541
KOMATSU	D150-1	S/N 6843 & UP	UNSEALED	1.929	11.535	9	915086	B3635	A3541
KOMATSU	D155		SEALED	1.988	11.3	9	915055	B3635	A3541
KOMATSU	D155		SALT	1.909	11.57	9	915055	B3635	A3541
KOMATSU	D155-1	S/N 6842 & DN	SEALED	1.988	11.3	9	915055	B3635	A3541
KOMATSU	D155-1	S/N 6843 & UP	SEALED	1.929	11.54	9	915086	B3635	A3541
KOMATSU	D155-1		SALT	1.909	11.57	9	915055	B3635	A3541
KOMATSU	D155-1	S/N 6843 & UP	UNSEALED	1.929	11.535	9	915086	B3635	A3541
KOMATSU	D155-1	S/N 6842 & DN	UNSEALED	1.988	11.299	9	915055	B3635	A3541
KOMATSU	D155-1	S/N 10263-19064	SEALED	1.9069	11.5747	9	915087	B3635	A3541
KOMATSU	D155-1	S/N 19065 & UP	SALT	1.9094	11.574	9	915087	B3635	A3541
KOMATSU	D155A		SALT	1.909	11.57	9	915055	B3635	A3541
KOMATSU	D155A-1	S/N 2540-10262	SEALED	1.909	11.3	9	915055	B3635	A3541
KOMATSU	D155A-2		SALT	1.9094	11.574	9	915087	B3635	A3541
KOMATSU	D155A-2		SEALED	1.909	11.48	9	915087	B3635	A3541
KOMATSU	D155A-5		SEALED	1.909	11.48	9	915167	B3635	A3541
KOMATSU	D155AX-3		SEALED	1.909	11.48	9	915167	B3635	A3541
KOMATSU	D155AX-5		SEALED	1.909	11.48	9	915167	B3635	A3541

WTC Machinery
MPP 250 Tooling Chart

				Pin Dimensions				Disassembly Tools	
Make	Model	Comments	Type	Dia	Length	Pitch	PAT	Pin Tool	Back. Bush.
KOMATSU	D20		SEALED	0.945	5.63	5.31	915124	A3536	A3539
KOMATSU	D20		SALT	0.945	5.55	5.31	915123	A3536	A3539
KOMATSU	D21		SEALED	0.945	5.63	5.31	915124	A3536	A3539
KOMATSU	D21		SALT	0.945	5.55	5.31	915123	A3536	A3539
KOMATSU	D250		RECESSED	2.165	12.323	10.25	915054	B3607/8	A3541
KOMATSU	D275A-2		SALT	2.24	12.61	10.25	915063	B3607/8	A3541
KOMATSU	D30-15		SEALED	1.102	6.594	6.063	915057	A3536	A3539
KOMATSU	D30A		SEALED	1.102	6.594	6.063	915057	A3536	A3539
KOMATSU	D30S-1		SEALED	1.094	6.59	6.06	915058	A3536	A3539
KOMATSU	D30S-15	S/N 5016 & UP	SEALED	1.102	6.594	6.063	915057	A3536	A3539
KOMATSU	D31		UNSEALED	1.18	6.69	6.06	915069	A3536	A3539
KOMATSU	D31-15		SEALED	1.102	6.594	6.063	915057	A3536	A3539
KOMATSU	D31-16		SEALED	1.102	6.693	6.063	915058	A3536	A3539
KOMATSU	D31-16		SALT	1.102	6.6929	6.0629	915058	A3536	A3539
KOMATSU	D31E		SALT	1.102	6.6929	6.0629	915058	A3536	A3539
KOMATSU	D31E-12		SEALED	1.102	6.594	6.063	915057	A3536	A3539
KOMATSU	D31P		UNSEALED	1.18	6.69	6.06	915069	A3536	A3539
KOMATSU	D31P		SALT	1.102	6.6929	6.0629	915058	A3536	A3539
KOMATSU	D31P-20		SALT	1.102	6.6929	6.0629	915058	A3536	A3539
KOMATSU	D31PL		SALT	1.102	6.6929	6.0629	915058	A3536	A3539
KOMATSU	D31PLL	S/N 29001 & UP	SALT	1.102	6.6929	6.0629	915058	A3536	A3539

WTC Machinery
MPP 250 Tooling Chart

				Pin Dimensions				Disassembly Tools	
Make	Model	Comments	Type	Dia	Length	Pitch	PAT	Pin Tool	Back. Bush.
KOMATSU	D31PX		SALT	1.102	6.6929	6.0629	915058	A3536	A3539
KOMATSU	D31S		SALT	1.102	6.6929	6.0629	915058	A3536	A3539
KOMATSU	D355		FLUSH	2.244	12.579	10.25	915053	B3607/8	A3541
KOMATSU	D355		SALT	2.185	12.736	10.25	915091	B3607/8	A3541
KOMATSU	D355A-1	S/N 1010-1631	SEALED	2.244	12.578	10.25	915088	B3607/8	A3541
KOMATSU	D355A-3	S/N 1632-4233	SEALED	2.185	12.736	10.25	915091	B3607/8	A3541
KOMATSU	D355A-3	S/N 4234 & UP	SALT	2.185	12.736	10.25	915091	B3607/8	A3541
KOMATSU	D37		SALT	1.102	6.6929	6.0629	915058	A3536	A3539
KOMATSU	D375		SALT	2.24	12.61	10.25	915063	B3607/8	A3541
KOMATSU	D375A-1		SALT	2.24	12.61	10.25	915063	B3607/8	A3541
KOMATSU	D375A-2		SALT	2.36	12.77	11.04	915131	B3607/8	A3541
KOMATSU	D375A-3		SALT	2.36	12.77	11.04	915131	B3607/8	A3541
KOMATSU	D375A-5		SALT	2.362	12.77	11.04	915165	B3607/8	A3541
KOMATSU	D37P		SALT	1.102	6.6929	6.0629	915058	A3536	A3539
KOMATSU	D39E		SALT	1.307	7.244	6.75	915052	A3537	A3540
KOMATSU	D39EX		SALT	1.307	7.244	6.75	915052	A3537	A3540
KOMATSU	D39P		SALT	1.307	7.244	6.75	915052	A3537	A3540
KOMATSU	D39PX		SALT	1.307	7.244	6.75	915052	A3537	A3540
KOMATSU	D40		RECESSED	1.488	8.5826	6.89	915059	B3635	A3541
KOMATSU	D40		SALT	1.377	7.13	6.89	915060	B3635	A3541
KOMATSU	D40		SEALED	1.382	7.17	6.89	915060	B3635	A3541

WTC Machinery
MPP 250 Tooling Chart

				Pin Dimensions				Disassembly Tools	
Make	Model	Comments	Type	Dia	Length	Pitch	PAT	Pin Tool	Back. Bush.
KOMATSU	D40P-1	BERCO	SEALED	1.496	8.661	6.906	915059	B3635	A3541
KOMATSU	D41	NEW	SALT	1.382	7.17	6.89	915122	B3635	A3541
KOMATSU	D41		UNSEALED	1.499	8.66	6.89	915122	B3635	A3541
KOMATSU	D41		SEALED	1.382	7.17	6.89	915060	B3635	A3541
KOMATSU	D41-6		SALT	1.307	7.244	6.75	915052	A3537	A3540
KOMATSU	D41A	BERCO	SEALED	1.496	8.661	6.906	915059	B3635	A3541
KOMATSU	D41E	S/N 50201 & UP	SALT	1.307	7.224	6.75	915067	A3537	A3540
KOMATSU	D41E		SALT	1.307	7.244	6.75	915052	A3537	A3540
KOMATSU	D41P		SALT	1.307	7.244	6.75	915052	A3537	A3540
KOMATSU	D41P	BERCO	SEALED	1.496	8.661	6.906	915059	B3635	A3541
KOMATSU	D41P-6	S/N 50201 & UP	SALT	1.307	7.224	6.75	915067	A3537	A3540
KOMATSU	D41PX-12		SALT	1.432	7.845	6.875	915163	B3635	A3541
KOMATSU	D41Q-3	BERCO	SEALED	1.496	8.661	6.906	915059	B3635	A3541
KOMATSU	D41S	BERCO	SEALED	1.496	8.661	6.906	915059	B3635	A3541
KOMATSU	D45		RECESSED	1.488	8.5826	6.89	915059	B3635	A3541
KOMATSU	D455		SALT	2.76	14.37	12.5	915090	B3605/6	A4157
KOMATSU	D455A-1	S/N 1334 & UP	SALT	2.7559	14.37	12.5	915090	B3605/6	A4157
KOMATSU	D455A-1	S/N 1004-1089	SALT	2.76	14.37	12.5	915090	B3605/6	A4157
KOMATSU	D45A		SEALED	1.382	7.17	6.89	915059	B3635	A3541
KOMATSU	D45A	S/N 12178 & UP BERCO	SEALED	1.496	8.661	6.906	915059	B3635	A3541
KOMATSU	D45B	S/N 12178 & UP BERCO	SEALED	1.496	8.661	6.906	915059	B3635	A3541

WTC Machinery
MPP 250 Tooling Chart

				Pin Dimensions				Disassembly Tools	
Make	Model	Comments	Type	Dia	Length	Pitch	PAT	Pin Tool	Back. Bush.
KOMATSU	D45P-1	S/N 1501 & UP	SEALED	1.382	7.17	6.89	915059	B3635	A3541
KOMATSU	D475A-1		SALT	2.76	14.4	12.51	915107	B3605/6	A4157
KOMATSU	D475A-2		SALT	2.76	14.4	12.51	915107	B3605/6	A4157
KOMATSU	D475A-3		SALT	2.76	13.78	12.51	915239	B3605/6	A4157
KOMATSU	D475A-5		SALT	2.76	13.78	12.51	915238	B3605/6	A4157
KOMATSU	D50		RECESSED	1.488	8.5826	6.89	915059	B3635	A3541
KOMATSU	D50		SALT	1.377	7.13	6.89	915060	B3635	A3541
KOMATSU	D50		SEALED	1.382	7.17	6.89	915060	B3635	A3541
KOMATSU	D50-11		RECESSED	1.488	8.5826	6.89	915059	B3635	A3541
KOMATSU	D50-15		RECESSED	1.488	8.5826	6.89	915059	B3635	A3541
KOMATSU	D50-15		SEALED	1.382	7.17	6.89	915059	B3635	A3541
KOMATSU	D50A	BERCO	SEALED	1.496	8.661	6.906	915059	B3635	A3541
KOMATSU	D50B	S/N 10901 & UP BERCO	SEALED	1.496	8.661	6.906	915059	B3635	A3541
KOMATSU	D50P	S/N 10901 & UP BERCO	SEALED	1.496	8.661	6.906	915059	B3635	A3541
KOMATSU	D50S	S/N 10901 & UP BERCO	SEALED	1.496	8.661	6.906	915059	B3635	A3541
KOMATSU	D50S-11		RECESSED	1.488	8.5826	6.89	915059	B3635	A3541
KOMATSU	D53	NEW	SALT	1.382	7.17	6.89	915122	B3635	A3541
KOMATSU	D53		UNSEALED	1.499	8.66	6.89	915122	B3635	A3541
KOMATSU	D53		SALT	1.377	7.13	6.89	915060	B3635	A3541
KOMATSU	D53-15		SEALED	1.382	7.17	6.89	915059	B3635	A3541
KOMATSU	D53-16		SEALED	1.382	7.17	6.89	915060	B3635	A3541

WTC Machinery
MPP 250 Tooling Chart

				Pin Dimensions				Disassembly Tools	
Make	Model	Comments	Type	Dia	Length	Pitch	PAT	Pin Tool	Back. Bush.
KOMATSU	D53A	BERCO	SEALED	1.496	8.661	6.906	915059	B3635	A3541
KOMATSU	D53A-15	S/N 60001 & UP	SEALED	1.382	7.17	6.89	915059	B3635	A3541
KOMATSU	D55		SEALED	1.496	8.661	7.48	915060	B3635	A3541
KOMATSU	D55-S		RECESSED	1.488	8.583	7.48	915056	B3635	A3541
KOMATSU	D57-1		SEALED	1.496	8.661	7.48	915060	B3635	A3541
KOMATSU	D575-1		DRY TRACK	1.5	8.66	7.48	915233	B3635	A3541
KOMATSU	D575A-2		SALT	2.913	17.32	12.508		B3605/6	FALSE
KOMATSU	D575A-3		SALT	2.913	17.32	12.508		B3605/6	FALSE
KOMATSU	D57S-1		SEALED	1.496	8.661	7.48	915060	B3635	A3541
KOMATSU	D58		SALT	1.377	7.13	6.89	915060	B3635	A3541
KOMATSU	D58		SEALED	1.382	7.17	6.89	915060	B3635	A3541
KOMATSU	D58E	BERCO	SEALED	1.496	8.661	6.906	915059	B3635	A3541
KOMATSU	D58P-1	BERCO	SEALED	1.496	8.661	6.906	915059	B3635	A3541
KOMATSU	D6	S/N 50001-50200	SALT	1.307	7.244	6.75	915052	A3537	A3540
KOMATSU	D60		SEALED	1.76	9.433	8	915084	B3635	A3541
KOMATSU	D60		SALT	1.75	9.433	8	915084	B3635	A3541
KOMATSU	D60-6		SEALED	1.752	9.26	8	915062	B3635	A3541
KOMATSU	D60A	BERCO NON-OEM	SEALED	1.756	9.449	7.984	915116	B3635	A3541
KOMATSU	D60-A		RECESSED	1.488	8.583	7.48	915056	B3635	A3541
KOMATSU	D61		SALT	1.496	8.897	7.48	915060	B3635	A3541
KOMATSU	D61E		SALT	1.496	8.897	7.48	915060	B3635	A3541

WTC Machinery
MPP 250 Tooling Chart

				Pin Dimensions				Disassembly Tools	
Make	Model	Comments	Type	Dia	Length	Pitch	PAT	Pin Tool	Back. Bush.
KOMATSU	D61EX		SALT	1.496	8.897	7.48	915060	B3635	A3541
KOMATSU	D61P		SALT	1.496	8.897	7.48	915060	B3635	A3541
KOMATSU	D61PX		SALT	1.496	8.897	7.48	915060	B3635	A3541
KOMATSU	D61PX-12		SALT	1.496	8.897	7.48	915060	B3635	A3541
KOMATSU	D63E		SALT	1.377	7.13	6.89	915060	B3635	A3541
KOMATSU	D63E		SEALED	1.382	7.17	6.89	915060	B3635	A3541
KOMATSU	D65		SEALED	1.76	9.433	8	915084	B3635	A3541
KOMATSU	D65		SALT	1.75	9.433	8	915084	B3635	A3541
KOMATSU	D65-6	S/N 34001 & UP	SALT	1.7559	9.5275	8	915097	B3635	A3541
KOMATSU	D65A	BERCO NON-OEM	SEALED	1.756	9.449	7.984	915116	B3635	A3541
KOMATSU	D65A		SEALED	1.76	9.433	8	915084	B3635	A3541
KOMATSU	D65E		SEALED	1.76	9.433	8	915084	B3635	A3541
KOMATSU	D65EX-12		SALT	1.75	9.433	8	915084	B3635	A3541
KOMATSU	D65EX-15		SALT	1.75	9.433	8	915084	B3635	A3541
KOMATSU	D65P-6	S/N 20006 & UP	SEALED	1.76	9.433	8	915084	B3635	A3541
KOMATSU	D65PX		SALT	1.75	9.433	8	915084	B3635	A3541
KOMATSU	D65PX-12		SALT	1.75	9.433	8	915084	B3635	A3541
KOMATSU	D65PX-15		SALT	1.75	9.433	8	915084	B3635	A3541
KOMATSU	D66		SEALED	1.76	9.433	8	915084	B3635	A3541
KOMATSU	D66		SALT	1.7559	9.5275	8	915097	B3635	A3541
KOMATSU	D68		SEALED	1.76	9.433	8	915084	B3635	A3541

WTC Machinery
MPP 250 Tooling Chart

				Pin Dimensions				Disassembly Tools	
Make	Model	Comments	Type	Dia	Length	Pitch	PAT	Pin Tool	Back. Bush.
KOMATSU	D68		SALT	1.7559	9.5275	8	915097	B3635	A3541
KOMATSU	D75		SEALED	1.8425	10	8.5039	915096	B3635	A3541
KOMATSU	D75		SALT	1.8503	10	8.5039	915096	B3635	A3541
KOMATSU	D75-S		SEALED	1.85	9.842	8.504	915015	B3635	A3541
KOMATSU	D80		SEALED	1.8425	10	8.5039	915096	B3635	A3541
KOMATSU	D80		SALT	1.8503	10	8.5039	915096	B3635	A3541
KOMATSU	D80-7		SEALED	1.752	9.842	8	915013	B3635	A3541
KOMATSU	D80-8		SEALED	1.752	9.842	8	915013	B3635	A3541
KOMATSU	D85		SEALED	1.771	9.842	8.504	915085	B3635	A3541
KOMATSU	D85		SALT	1.8503	10	8.5039	915096	B3635	A3541
KOMATSU	D85-18	S/N 26514 & UP	SALT	1.8503	10	8.5039	915096	B3635	A3541
KOMATSU	D85-18	S/N 26513 & DN	SEALED	1.85	10	8.5	915232	B3635	A3541
KOMATSU	D85A		SEALED	1.771	9.842	8.504	915085	B3635	A3541
KOMATSU	D85A		SEALED	1.8425	10	8.5039	915096	B3635	A3541
KOMATSU	D85A-12		SEALED	1.85	9.842	8.504	915015	B3635	A3541
KOMATSU	D85E		SEALED	1.8425	10	8.5039	915096	B3635	A3541
KOMATSU	D85E-12	S/N 10001 & UP	SEALED	1.771	9.842	8.504	915085	B3635	A3541
KOMATSU	D85E-12		SEALED	1.771	9.842	8.504	915085	B3635	A3541
KOMATSU	D85EX-15		SALT	1.8503	10	8.5039	915096	B3635	A3541
KOMATSU	D85P-18		SEALED	1.8425	10	8.5039	915096	B3635	A3541
KOMATSU	D85PX		SALT	1.8503	10	8.5039	915096	B3635	A3541

WTC Machinery
MPP 250 Tooling Chart

				Pin Dimensions				Disassembly Tools	
Make	Model	Comments	Type	Dia	Length	Pitch	PAT	Pin Tool	Back. Bush.
KOMATSU	D85PX-15		SALT	1.8503	10	8.5039	915096	B3635	A3541
KOMATSU	D95		SALT	1.8503	10	8.5039	915096	B3635	A3541
KOMATSU	D95		SEALED	1.8425	10	8.5039	915096	B3635	A3541
KOMATSU	D95-S		SEALED	1.772	10	8.5	915232	B3635	A3541
KOMATSU	PC100		UNSEALED	1.18	6.69	6.06	915069	A3536	A3539
KOMATSU	PC100	PITCH ALSO 6.89	SEALED	1.181	6.811	6.063	915126	A3536	A3539
KOMATSU	PC100		SEALED	1.18	6.81	6.89	915161	A3536	A3539
KOMATSU	PC1000		SEALED	2.244	12.614	10.25	915063	B3607/8	A3541
KOMATSU	PC1000-1		SALT	2.24	12.61	10.25	915063	B3607/8	A3541
KOMATSU	PC1000SE-1		SALT	2.24	12.61	10.25	915063	B3607/8	A3541
KOMATSU	PC100-1		SEALED	1.181	6.535	6.062	915110	A3536	A3539
KOMATSU	PC100-2		SEALED	1.181	6.535	6.062	915110	A3536	A3539
KOMATSU	PC100-3		SEALED	1.181	6.535	6.062	915110	A3536	A3539
KOMATSU	PC100-6		SEALED	1.18	6.81	6.89	915161	A3536	A3539
KOMATSU	PC100L-6		SEALED	1.49	8.66	7.49	915060	B3635	A3541
KOMATSU	PC1100-6		DRY TRACK	2.36	12.77	11.03	915131	B3607/8	A3541
KOMATSU	PC1100LC-6		DRY TRACK	2.36	12.77	11.03	915131	B3607/8	A3541
KOMATSU	PC1100SP-6		DRY TRACK	2.36	12.77	11.03	915131	B3607/8	A3541
KOMATSU	PC120		SEALED	1.18	6.81	6.89	915161	A3536	A3539
KOMATSU	PC120	PITCH ALSO 6.89	SEALED	1.181	6.811	6.063	915126	A3536	A3539
KOMATSU	PC120-1		SEALED	1.181	6.535	6.062	915110	A3536	A3539

WTC Machinery
MPP 250 Tooling Chart

				Pin Dimensions				Disassembly Tools	
Make	Model	Comments	Type	Dia	Length	Pitch	PAT	Pin Tool	Back. Bush.
KOMATSU	PC120-2		SEALED	1.181	6.535	6.062	915110	A3536	A3539
KOMATSU	PC120-3		SEALED	1.181	6.535	6.062	915110	A3536	A3539
KOMATSU	PC120-6			1.181	6.811	6.9	915231	A3536	A3539
KOMATSU	PC120-6			1.181	6.811	6.89	915126	A3536	A3539
KOMATSU	PC120LC-6		SEALED	1.18	6.81	6.89	915161	A3536	A3539
KOMATSU	PC1250		DRY TRACK	2.36	12.77	11.03	915131	B3607/8	A3541
KOMATSU	PC1250-7		DRY TRACK	2.36	12.77	11.03	915131	B3607/8	A3541
KOMATSU	PC1250LC-7		DRY TRACK	2.36	12.77	11.03	915131	B3607/8	A3541
KOMATSU	PC1250SP-7		DRY TRACK	2.36	12.77	11.03	915131	B3607/8	A3541
KOMATSU	PC130-6		SEALED	1.18	6.81	6.89	915161	A3536	A3539
KOMATSU	PC138		SEALED	1.18	6.81	6.89	915161	A3536	A3539
KOMATSU	PC150		UNSEALED	1.499	8.66	6.89	915122	B3635	A3541
KOMATSU	PC1600		SALT	2.76	13.78	12.51	915107	B3605/6	A4157
KOMATSU	PC200		SEALED	1.496	8.661	7.48	915060	B3635	A3541
KOMATSU	PC2000		SALT	2.76	13.78	12.51	915107	B3605/6	A4157
KOMATSU	PC200-6		SEALED	1.496	8.661	7.48	915060	B3635	A3541
KOMATSU	PC200-7		SEALED	1.496	8.661	7.48	915060	B3635	A3541
KOMATSU	PC200-8		SEALED	1.496	8.661	7.48	915060	B3635	A3541
KOMATSU	PC220		SEALED	1.496	8.661	7.48	915060	B3635	A3541
KOMATSU	PC240LC-6		SEALED	1.496	8.661	7.48	915060	B3635	A3541
KOMATSU	PC250LC-6		SEALED	1.75	9.52	8.5	915159	B3635	A3541

WTC Machinery
MPP 250 Tooling Chart

				Pin Dimensions				Disassembly Tools	
Make	Model	Comments	Type	Dia	Length	Pitch	PAT	Pin Tool	Back. Bush.
KOMATSU	PC270LC-6		SEALED	1.75	9.52	8.5	915159	B3635	A3541
KOMATSU	PC270LC-7		SEALED	1.75	9.52	8.5	915159	B3635	A3541
KOMATSU	PC300	EXC	SALT	1.75	9.53	8	915097	B3635	A3541
KOMATSU	PC300	EXC	SEALED	1.76	9.53	8	915076	B3635	A3541
KOMATSU	PC300HD-6		SEALED	1.85	9.92	9	915160	B3635	A3541
KOMATSU	PC300LC-6		SEALED	1.75	9.52	8.5	915159	B3635	A3541
KOMATSU	PC300LC-7		SEALED	1.75	9.52	8.5	915159	B3635	A3541
KOMATSU	PC-400 EX		SEALED	1.85	10	8.504	915232	B3635	A3541
KOMATSU	PC400-3		SEALED	1.8425	10	8.5039	915096	B3635	A3541
KOMATSU	PC400-5		SEALED	1.8425	10	8.5039	915096	B3635	A3541
KOMATSU	PC400-6		SEALED	1.85	10	9	915096	B3635	A3541
KOMATSU	PC400-6		SEALED	1.8425	10	8.5039	915096	B3635	A3541
KOMATSU	PC400LC-7		SEALED	1.85	10	9	915096	B3635	A3541
KOMATSU	PC400LCSE-7		SEALED	1.85	10	9	915096	B3635	A3541
KOMATSU	PC450		SEALED	1.85	10	9	915096	B3635	A3541
KOMATSU	PC60	EXC	SEALED	0.945	5.55	5.31	915123	A3536	A3539
KOMATSU	PC600		SEALED	2.185	12.614	10.25	915125	B3607/8	A3541
KOMATSU	PC600	EXC	SEALED	1.85	10	8.504	915232	B3635	A3541
KOMATSU	PC600-6			1.92	11.41	9	915177	B3635	A3541
KOMATSU	PC600-7			1.92	11.41	9	915177	B3635	A3541
KOMATSU	PC600LC-6			1.92	11.41	9	915177	B3635	A3541

WTC Machinery
MPP 250 Tooling Chart

				Pin Dimensions				Disassembly Tools	
Make	Model	Comments	Type	Dia	Length	Pitch	PAT	Pin Tool	Back. Bush.
KOMATSU	PC600LC-7			1.92	11.41	9	915177	B3635	A3541
KOMATSU	PC650-5		SEALED	2.185	12.614	10.25	915125	B3607/8	A3541
KOMATSU	PC700		SEALED	2.185	12.614	10.25	915125	B3607/8	A3541
KOMATSU	PC710		SEALED	2.185	12.614	10.25	915125	B3607/8	A3541
KOMATSU	PC750		DRY TRACK	2.2	12.61	10.25	915125	B3607/8	A3541
KOMATSU	PC750SE-6		SEALED	2.185	12.614	10.25	915125	B3607/8	A3541
KOMATSU	PC80	PITCH ALSO 6.89	SEALED	1.181	6.811	6.063	915126	A3536	A3539
KOMATSU	PC800		SEALED	2.185	12.614	10.25	915125	B3607/8	A3541
KOMATSU	PC80-1		SEALED	1.181	6.535	6.062	915110	A3536	A3539
KOMATSU	PC80-3		SEALED	1.181	6.535	6.062	915110	A3536	A3539
KUBOTA	KH170L	EXC	UNSEALED	0.994	5.51	5.31	915040	A3536	A3539
LIEBHERR	631	MAY WORK	SALT	1.752	9.06	7.985	915003	B3635	A3541
LIEBHERR	PR711		SALT	1.315	7.22	6.735	915052	A3537	A3540
LIEBHERR	PR721		SALT	1.442	8.12	6.735	915052	B3635	A3541
LIEBHERR	PR731		SALT	1.752	9.06	7.985	915003	B3635	A3541
LIEBHERR	R912		SEALED	1.314	7	6.735	915002	A3537	A3540
LIEBHERR	R922		SEALED	1.314	7	6.735	915002	A3537	A3540
LIEBHERR	R932		SEALED	1.442	8.13	6.735	915009	B3635	A3541
LINKBELT	LS2800		SEALED	1.442	8.13	6.735	915009	B3635	A3541
LINKBELT	LS4800		SEALED	1.878	9.88	8.5	915012	B3635	A3541
LINKBELT	LS5400		SEALED	1.878	9.88	8.5	915012	B3635	A3541

WTC Machinery
MPP 250 Tooling Chart

				Pin Dimensions				Disassembly Tools	
Make	Model	Comments	Type	Dia	Length	Pitch	PAT	Pin Tool	Back. Bush.
LINKBELT	LS5800		SEALED	1.878	9.88	8.5	915012	B3635	A3541
LINKBELT	LS6400		SEALED	2.003	11.44	9	915001	B3635	A3541
LINKBELT	LS7400		SEALED	2.003	11.44	9	915001	B3635	A3541
LINKBELT	LS7800		SEALED	1.442	8.13	6.735	915009	B3635	A3541
LINKBELT	LS9800		SEALED	1.752	9.88	7.985	915012	B3635	A3541
MASSEY-FERGUSSON	MF200B		SEALED	1.063	5.75	5.512	915004	A3536	A3539
MASSEY-FERGUSSON	MF2244		RECESSED	0.984	5.42	5.512	915057	A3536	A3539
MASSEY-FERGUSSON	MF300		RECESSED	1.299	6.61	6.299	915002	A3537	A3540
MASSEY-FERGUSSON	MF300		SEALED	1.299	6.61	6.299	915078	A3537	A3540
MASSEY-FERGUSSON	MF400C		SEALED	1.38	7.01	6.69	915078	B3635	A3541
MASSEY-FERGUSSON	MF450		RECESSED	1.299	6.61	6.299	915002	A3537	A3540
MASSEY-FERGUSSON	MF500		RECESSED	1.378	7.17	6.69	915080	B3635	A3541
MASSEY-FERGUSSON	MF500B		SEALED	1.441	8.11	6.75	915079	B3635	A3541
MASSEY-FERGUSSON	MF600C		SEALED	1.752	8.66	7.98	915081	B3635	A3541
MASSEY-FERGUSSON	MFD400C		SEALED	1.38	7.01	6.69	915078	B3635	A3541
MASSEY-FERGUSSON	MFD700C		SEALED	1.88	9.88	8.5	915062	B3635	A3541
TEREX	82-20AA,		RECESSED	1.75	9.19	8	915075	B3635	A3541
TEREX	82-30		RECESSED	1.75	9.19	8	915075	B3635	A3541
TEREX	82-30AA		RECESSED	1.75	11.52	8	915021	B3635	A3541
TEREX	82-30B		RECESSED	2	11.52	9	915077	B3635	A3541
TEREX	82-30FA		RECESSED	1.75	11.52	8	915021	B3635	A3541

WTC Machinery
MPP 250 Tooling Chart

				Pin Dimensions				Disassembly Tools	
Make	Model	Comments	Type	Dia	Length	Pitch	PAT	Pin Tool	Back. Bush.
TEREX	82-40AA		RECESSED	1.75	11.52	8	915021	B3635	A3541
TEREX	82-40CA		RECESSED	1.75	11.52	8	915021	B3635	A3541
TEREX	82-40DA		RECESSED	2	11.52	9	915077	B3635	A3541
TEREX	82-50		RECESSED	2.38	12.38	10.312	915063	B3607/8	A3541
TEREX	82-80DA		RECESSED	2	12.38	9	915076	B3635	A3541
TEREX	TC-12		RECESSED	2	12.38	9	915076	B3635	A3541
VOLVO	EC150LC			1.496	8.1875	7.5	915234	B3635	A3541