

MPP 100 Tooling Chart

WTC Machinery, LLC

W1222 Linden Road

Ixonia, Wisconsin 53036 USA

Phone: 800.248.8405 or 262.567.3993

Fax: 262.567.4304 or 262.569.4850

MASTER PIN REMOVAL

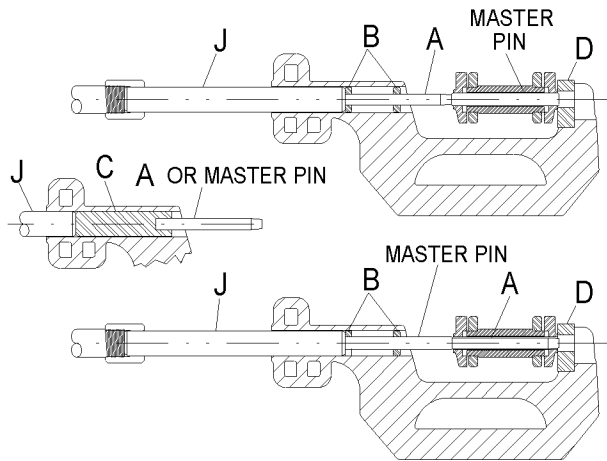

MASTER PIN INSTALLATION

⚠ WARNING: To help prevent personal injury, do not use this tooling beyond its maximum working force of 100 tons (90.9 tonnes)

IMPORTANT: To help prevent equipment damage, remove aligning bushings ("B") if used, BEFORE the final push is made.

MASTER BUSHING REMOVAL

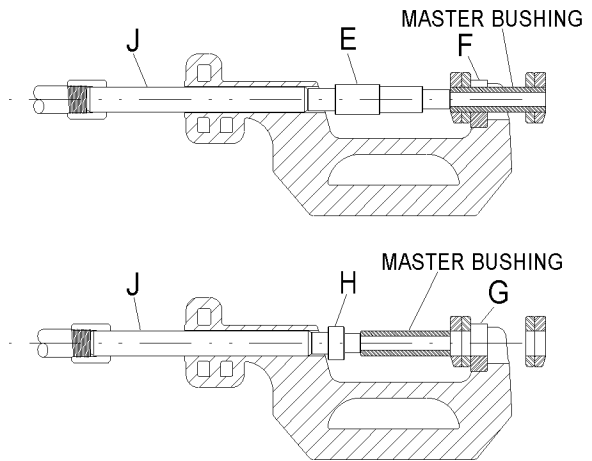

MASTER BUSHING INSTALLATION

Table of Contents

Case	pg. 1-7
Caterpillar	pg. 7-33
Dresser	pg. 33-41
Fiat	pg. 41-63
Fowler	pg. 63
Hanomag	pg. 63
Hitachi	pg. 63
Intertrac	pg. 65-69
John Deere	pg. 69-79
Komatsu	pg. 79-101
Kuboto	pg. 101
Liebherr	pg. 101
Linkbelt	pg. 101-103
Massey Ferguson	pg. 103-105
Terex	pg. 105-107
Volvo	pg. 107

WTC Machinery
MPP 100 Tooling Chart

				MASTER PIN RMOVAL AND INSTALLATION					
MAKE	MODEL	COMMENTS	PITCH	PIN LENGTH	PIN DIA	FORCING PIN (A)	ALIGNING BUSHING (2)(B)		PILOT PIN ©
							REMOVAL	INSTALL	
CASE	200		5.875	5.220	0.992	200281	Not Req'd	Not Req'd	25505
CASE	300		5.875	5.220	0.992	200281	Not Req'd	Not Req'd	25505
CASE	310		5.875	5.220	0.992	200281	Not Req'd	Not Req'd	25505
CASE	320		5.875	5.220	0.992	200281	Not Req'd	Not Req'd	25505
CASE	350		5.875	5.22	0.993	200281	Not Req'd	Not Req'd	25505
CASE	350		5.875	5.220	0.992	200281	Not Req'd	Not Req'd	25505
CASE	400		5.875	5.220	0.992	200281	Not Req'd	Not Req'd	25505
CASE	420		5.875	5.220	0.992	200281	Not Req'd	Not Req'd	25505
CASE	450		5.75	5.38	1.187	25498	Not Req'd	Not Req'd	25504
CASE	450		5.875	5.375	1.058	200281	Not Req'd	Not Req'd	25505
CASE	500		5.875	5.220	0.992	200281	Not Req'd	Not Req'd	25505
CASE	520		5.875	5.220	0.992	200281	Not Req'd	Not Req'd	25505
CASE	550		6.29	6.575	1.129	200281	Not Req'd	Not Req'd	25504
CASE	600		5.875	5.375	1.063	200281	Not Req'd	Not Req'd	25505
CASE	600		5.875	5.375	1.058	200281	Not Req'd	Not Req'd	25505
CASE	650		6.735	7.224	1.318	25499	Not Req'd	Not Req'd	25502

WTC Machinery
MPP 100 Tooling Chart

				BUSHING REMOVAL		BUSHING INSTALL			
MODEL	ALIGNING ADAPTOR (D)	BUSHING ID	BUSHING OD	BUSHING PUSHER (E)	BUSHING ADAPTER (F)	REAR BUSH ASSY PLATE (G)	BUSHING INSTALLER (H)	REAR FORCING PIN (J)	SPECIAL TOOLING
200	32435	1.005	1.500	35199	32437	N/A	35204	33934	None
300	32435	1.005	1.500	35199	32437	N/A	35204	33934	None
310	32435	1.005	1.500	35199	32437	N/A	35204	33934	None
320	32435	1.005	1.500	35199	32437	N/A	35204	33934	None
350	32435	N/A	1.5	35199	32437	35202	35204	33934	None
350	32435	1.005	1.500	35199	32437	N/A	35204	33934	None
400	32435	1.005	1.500	35199	32437	N/A	35204	33934	None
420	32435	1.005	1.500	35199	32437	N/A	35204	33934	None
450	32435	N/A	1.75	35199	33471	35202	EITHER	33934	None
450	32435	1.078	1.625	35199	33471	N/A	35204	33934	None
500	32435	1.005	1.500	35199	32437	N/A	35204	33934	None
520	32435	1.005	1.500	35199	32437	N/A	35204	33934	None
550	32435	N/A	1.966	35199	35205	35202	EITHER	33934	None
600	32435	N/A	1.625	35199	33471	35202	35204	33934	None
600	32435	1.078	1.625	35199	33471	N/A	35204	33934	None
650	22471	N/A	2.119	35199	35205	25562	25546	33936	None

WTC Machinery
MPP 100 Tooling Chart

				MASTER PIN RMOVAL AND INSTALLATION					
MAKE	MODEL	COMMENTS	PITCH	PIN LENGTH	PIN DIA	FORCING PIN (A)	ALIGNING BUSHING (2)(B)		PILOT PIN ©
							REMOVAL	INSTALL	
CASE	650		6.735	7.224	1.318	25499	Not Req'd	Not Req'd	25502
CASE	750		6.25	6.94	1.374	25499	Not Req'd	Not Req'd	25502
CASE	750	LDR	6.250	6.940	1.370	25499	Not Req'd	Not Req'd	25502
CASE	800		6.25	6.5	1.248	25498	Not Req'd	Not Req'd	25504
CASE	850		6.25	6.94	1.374	25499	Not Req'd	Not Req'd	25502
CASE	850		6.250	6.940	1.370	25499	Not Req'd	Not Req'd	25502
CASE	1000		6.25	6.5	1.248	25498	Not Req'd	Not Req'd	25504
CASE	1150	Recessed	6.25	6.94	1.374	25499	Not Req'd	Not Req'd	25502
CASE	1150	Sealed	6.25	6.94	1.374	25499	Not Req'd	Not Req'd	25502
CASE	1150		6.250	6.940	1.370	25499	Not Req'd	Not Req'd	25502
CASE	1450	Sealed	8.02	9.06	1.753	25548	22777	22751	Not Req'd
CASE	1450		8.020	9.250	1.752	25548	22777	22751	Not Req'd
CASE	1550		8.02	9.06	1.753	25548	22777	22751	Not Req'd
CASE	1000D		6.250	6.940	1.370	25499	Not Req'd	Not Req'd	25502
CASE	1000HD		6.25	6.94	1.374	25499	Not Req'd	Not Req'd	25502
CASE	1000HD		6.250	6.940	1.370	25499	Not Req'd	Not Req'd	25502

WTC Machinery
MPP 100 Tooling Chart

				BUSHING REMOVAL		BUSHING INSTALL			
MODEL	ALIGNING ADAPTOR (D)	BUSHING ID	BUSHING OD	BUSHING PUSHER (E)	BUSHING ADAPTER (F)	REAR BUSH ASSY PLATE (G)	BUSHING INSTALLER (H)	REAR FORCING PIN (J)	SPECIAL TOOLING
650	22471	N/A	2.119	35199	35205	25562	25546	33936	None
750	33472	N/A	1.995	35199	35205	35202	25546	33934	None
750	32437	1.390	1.997	35199	35205	N/A	25546	33934	None
800	32435	N/A	1.871	35199	33471	35202	EITHER	33934	None
850	33472	N/A	2	35199	35205	25562	25546	33934	None
850	32437	1.390	1.997	35199	35205	N/A	25546	33934	None
1000	32435	N/A	1.871	35199	33471	35202	EITHER	33934	None
1150	33472	N/A	1.995	35199	35205	35202	25546	33934	None
1150	33472	N/A	2	35199	35205	25562	25546	33934	None
1150	32437	1.390	1.997	35199	35205	N/A	25546	33934	None
1450	32441	N/A	2.62	35199	22769	25562	25546	33934	None
1450	33471	1.776	2.619	32434	22769	25563	25546	33934	None
1550	32441	N/A	2.62	35199	22769	25562	25546	33934	None
1000D	32437	1.390	1.997	35199	35205	N/A	25546	33934	None
1000HD	33472	N/A	1.995	35199	35205	35202	25546	33934	None
1000HD	32437	1.390	1.997	35199	35205	N/A	25546	33934	None

WTC Machinery
MPP 100 Tooling Chart

				MASTER PIN RMOVAL AND INSTALLATION					
MAKE	MODEL	COMMENTS	PITCH	PIN LENGTH	PIN DIA	FORCING PIN (A)	ALIGNING BUSHING (2)(B)		PILOT PIN ©
							REMOVAL	INSTALL	
CASE	1150 B		6.680	8.100	1.495	25500	22779	22779	Not Req'd
CASE	1150B		6.678	8.1	1.5	25500	Not Req'd	22777	Not Req'd
CASE	1150D		6.678	8.11	1.44	25500	Not Req'd	22779	Not Req'd
CASE	1150E		6.678	8.11	1.44	25500	Not Req'd	22779	Not Req'd
CASE	1155D		6.678	8.11	1.44	25500	Not Req'd	22779	Not Req'd
CASE	1155E		6.678	8.11	1.44	25500	Not Req'd	22779	Not Req'd
CASE	1450B	Sealed	8.02	9.06	1.753	25548	22777	22751	Not Req'd
CASE	1450B	SALT	8.02	9.06	1.753	25548	22777	22751	Not Req'd
CASE	1455B	SALT	8.02	9.06	1.753	25548	22777	22751	Not Req'd
CASE	1455B	Sealed	8.02	9.06	1.753	25548	22777	22751	Not Req'd
CASE	310G		5.875	5.22	0.993	200281	Not Req'd	Not Req'd	25505
CASE	350B		5.875	5.219	0.994	200281	Not Req'd	Not Req'd	25505
CASE	450A		6	6.54	1.25	25498	Not Req'd	Not Req'd	25502
CASE	450B		6	6.54	1.25	25498	Not Req'd	Not Req'd	25502
CASE	450C	SALT	6	6.46	1.129	200281	Not Req'd	Not Req'd	25504
CASE	450C	Sealed	6	6.457	1.129	200281	Not Req'd	Not Req'd	25504

WTC Machinery
MPP 100 Tooling Chart

				BUSHING REMOVAL		BUSHING INSTALL			
MODEL	ALIGNING ADAPTOR (D)	BUSHING ID	BUSHING OD	BUSHING PUSHER (E)	BUSHING ADAPTER (F)	REAR BUSH ASSY PLATE (G)	BUSHING INSTALLER (H)	REAR FORCING PIN (J)	SPECIAL TOOLING
1150 B	32437	1.515	2.188	35199	35205	N/A	25546	33936	None
1150B	32437	N/A	2.185	35199	35205	25562	25546	33936	None
1150D	33472	N/A	2.314	35199	35205	25562	25546	33936	None
1150E	33472	N/A	2.314	35199	35205	25562	25546	33936	None
1155D	33472	N/A	2.314	35199	35205	25562	25546	33936	None
1155E	33472	N/A	2.314	35199	35205	25562	25546	33936	None
1450B	32441	N/A	2.62	35199	22769	25562	25546	33934	None
1450B	32441	N/A	2.62	35199	22769	25562	25546	33934	None
1455B	32441	N/A	2.62	35199	22769	25562	25546	33934	None
1455B	32441	N/A	2.62	35199	22769	25562	25546	33934	None
310G	32435	N/A	3.18	32434	22771	25561	25546	33934	None
350B	32435	N/A	3.359	32434	31658	25561	25546	33934	None
450A	32435	N/A	4.31	35199	Not Req'd	25561	25546	33934	None
450B	32435	N/A	4.31	35199	Not Req'd	25561	25546	33934	None
450C	32435	N/A	1.85	35199	33471	35202	EITHER	33934	None
450C	32435	N/A	1.85	35199	33471	35202	EITHER	33934	None

WTC Machinery
MPP 100 Tooling Chart

				MASTER PIN RMOVAL AND INSTALLATION					
MAKE	MODEL	COMMENTS	PITCH	PIN LENGTH	PIN DIA	FORCING PIN (A)	ALIGNING BUSHING (2)(B)		PILOT PIN ©
							REMOVAL	INSTALL	
CASE	450HD		5.875	5.375	1.184	25498	Not Req'd	Not Req'd	25504
CASE	455C		6	6.46	1.129	200281	Not Req'd	Not Req'd	25504
CASE	550E		6.29	6.575	1.129	200281	Not Req'd	Not Req'd	25504
CASE	550G		6.29	6.575	1.129	200281	Not Req'd	Not Req'd	25504
CASE	850D		6.25	7.22	1.318	25499	Not Req'd	Not Req'd	25502
CASE	850D		6.735	7.224	1.318	25499	Not Req'd	Not Req'd	25502
CASE	850E		6.25	7.22	1.318	25499	Not Req'd	Not Req'd	25502
CASE	850E		6.735	7.224	1.318	25499	Not Req'd	Not Req'd	25502
CASE	850G		6.735	7.224	1.318	25499	Not Req'd	Not Req'd	25502
CASE	850H		6.735	7.224	1.318	25499	Not Req'd	Not Req'd	25502
CASE	850K		6.735	7.224	1.318	25499	Not Req'd	Not Req'd	25502
CASE	855D		6.25	7.22	1.318	25499	Not Req'd	Not Req'd	25502
CASE	855D		6.735	7.224	1.318	25499	Not Req'd	Not Req'd	25502
CASE	M3		5.875	5.220	0.992	200281	Not Req'd	Not Req'd	25505
CATERPILLAR	215	EXC (9/16" Bolt)	6.735	6.370	1.315	25499	Not Req'd	Not Req'd	25502
CATERPILLAR	215	EXC (5/8" Bolt)	6.735	7.22	1.315	25499	Not Req'd	Not Req'd	25502

WTC Machinery
MPP 100 Tooling Chart

				BUSHING REMOVAL		BUSHING INSTALL			
MODEL	ALIGNING ADAPTOR (D)	BUSHING ID	BUSHING OD	BUSHING PUSHER (E)	BUSHING ADAPTER (F)	REAR BUSH ASSY PLATE (G)	BUSHING INSTALLER (H)	REAR FORCING PIN (J)	SPECIAL TOOLING
450HD	32435	1.195	1.750	35199	33471	N/A	EITHER	33934	None
455C	32435	N/A	1.85	35199	33471	35202	EITHER	33934	None
550E	32435	N/A	1.996	35199	35205	35202	25546	33934	None
550G	32435	N/A	1.996	35199	35205	35202	25546	33934	None
850D	22471	N/A	1.995	35199	35205	35202	25546	33936	None
850D	22471	N/A	1.995	35199	35205	35202	25546	33936	None
850E	22471	N/A	2.119	35199	35205	25562	25546	33936	None
850E	22471	N/A	2.119	35199	35205	25562	25546	33936	None
850G	22471	N/A	2.119	35199	35205	25562	25546	33936	None
850H	22471	N/A	2.119	35199	35205	25562	25546	33936	None
850K	22471	N/A	2.119	35199	35205	25562	25546	33936	None
855D	22471	N/A	2.119	35199	35205	25562	25546	33936	None
855D	22471	N/A	2.119	35199	35205	25562	25546	33936	None
M3	32435	1.005	1.500	35199	32437	N/A	35204	33934	None
215	22471	N/A	2.120	35199	35205	25562	25546	33934	None
215	22471	N/A	2.12	35199	35205	25562	25546	33936	None

WTC Machinery
MPP 100 Tooling Chart

				MASTER PIN RMOVAL AND INSTALLATION					
MAKE	MODEL	COMMENTS	PITCH	PIN LENGTH	PIN DIA	FORCING PIN (A)	ALIGNING BUSHING (2)(B)		PILOT PIN ©
							REMOVAL	INSTALL	
CATERPILLAR	215		6.750	7.000	1.314	25499	Not Req'd	Not Req'd	25502
CATERPILLAR	219		7.480	8.120	1.442	25500	Not Req'd	22779	Not Req'd
CATERPILLAR	225	EXC	6.735	7.22	1.315	25499	Not Req'd	Not Req'd	25502
CATERPILLAR	225		6.750	7.000	1.314	25499	Not Req'd	Not Req'd	25502
CATERPILLAR	227		7.985	9.060	1.752	25548	22777	22751	Not Req'd
CATERPILLAR	229		7.985	9.060	1.752	25548	22777	22751	Not Req'd
CATERPILLAR	235	EXC	7.985	9.06	1.752	25548	22777	22751	Not Req'd
CATERPILLAR	235		8.500	9.813	1.877	25551	22751	22749	Not Req'd
CATERPILLAR	245		10.250	11.260	2.252	25501	Not Req'd	Not Req'd	Not Req'd
CATERPILLAR	311		6.750	7.010	1.321	25499	Not Req'd	Not Req'd	25502
CATERPILLAR	312	EXC	6.75	7.01	1.321	25499	Not Req'd	Not Req'd	25502
CATERPILLAR	315		7.480	8.150	1.442	25500	Not Req'd	22779	Not Req'd
CATERPILLAR	317		7.480	8.150	1.442	25500	Not Req'd	22779	Not Req'd
CATERPILLAR	318		7.480	8.150	1.442	25500	Not Req'd	22779	Not Req'd
CATERPILLAR	320	EXC	7.480	8.150	1.442	25500	Not Req'd	22779	Not Req'd
CATERPILLAR	320	EXC	7.48	8.15	1.442	25500	Not Req'd	22779	Not Req'd

WTC Machinery
MPP 100 Tooling Chart

				BUSHING REMOVAL		BUSHING INSTALL			
MODEL	ALIGNING ADAPTOR (D)	BUSHING ID	BUSHING OD	BUSHING PUSHER (E)	BUSHING ADAPTER (F)	REAR BUSH ASSY PLATE (G)	BUSHING INSTALLER (H)	REAR FORCING PIN (J)	SPECIAL TOOLING
215	33472	1.330	1.993	35199	35205	N/A	25546	33936	None
219	33472	N/A	2.312	35199	35205	25562	25546	33936	None
225	22471	N/A	2.118	35199	35205	25562	25546	33936	None
225	33472	1.330	1.993	35199	35205	N/A	25546	33936	None
227	32441	N/A	2.621	35199	22769	25562	35204	33934	None
229	32441	N/A	2.621	35199	22769	25562	35204	33934	None
235	32441	N/A	2.621	35199	22769	25562	35204	33934	None
235	33471	1.898	2.812	32434	22787	25563	25546	33934	None
245	33474	N/A	3.371	32434	31658	25561	25546	33934	None
311	22471	N/A	1.992	35199	35205	35202	25546	33936	None
312	22471	N/A	1.992	35199	35205	35202	25546	33936	None
315	33472	N/A	2.312	35199	35205	25562	25546	33936	None
317	33472	N/A	2.312	35199	35205	25562	25546	33936	None
318	33472	N/A	3.120	35199	22771	25561	25546	33936	None
320	33472	N/A	2.312	35199	35205	25562	25546	33936	None
320	33472	N/A	2.312	35199	35205	25562	25546	33936	None

WTC Machinery
MPP 100 Tooling Chart

				MASTER PIN RMOVAL AND INSTALLATION					
MAKE	MODEL	COMMENTS	PITCH	PIN LENGTH	PIN DIA	FORCING PIN (A)	ALIGNING BUSHING (2)(B)		PILOT PIN ©
							REMOVAL	INSTALL	
CATERPILLAR	322		7.480	8.150	1.442	25500	Not Req'd	22779	Not Req'd
CATERPILLAR	325	EXC	8.000	9.055	1.654	25547	22779	22751	Not Req'd
CATERPILLAR	330	EXC	8.500	9.665	1.811	25551	22751	22749	Not Req'd
CATERPILLAR	345	EXC	9.000	11.438	2.003	25551	22751	Not Req'd	Not Req'd
CATERPILLAR	375	EXC	10.250	12.244	2.253	25501	Not Req'd	Not Req'd	Not Req'd
CATERPILLAR	375	EXC	10.25	12.244	2.253	25501	Not Req'd	Not Req'd	Not Req'd
CATERPILLAR	561	PIPELAYER	6.906	8.120	1.442	25500	Not Req'd	22779	Not Req'd
CATERPILLAR	561		8.000	9.000	1.750	25548	22777	22751	Not Req'd
CATERPILLAR	571		7.985	9.880	1.752	25548	22777	22751	Not Req'd
CATERPILLAR	572		8.500	9.813	1.877	25551	22751	22749	Not Req'd
CATERPILLAR	572		8.5	9.88	1.878	25551	22751	22749	Not Req'd
CATERPILLAR	578	PIPELAYER	8.500	9.880	1.878	25551	22751	22749	Not Req'd
CATERPILLAR	578	PPR	8.500	9.650	1.878	25551	22751	22749	Not Req'd
CATERPILLAR	583		7.985	11.44	1.752	25548	22777	22751	Not Req'd
CATERPILLAR	583		8.000	11.438	1.740	25548	22777	22751	Not Req'd
CATERPILLAR	583		9.000	11.313	1.998	25551	22749	Not Req'd	Not Req'd

WTC Machinery
MPP 100 Tooling Chart

MODEL	ALIGNING ADAPTOR (D)	BUSHING ID	BUSHING OD	BUSHING REMOVAL		BUSHING INSTALL		REAR FORCING PIN (J)	SPECIAL TOOLING
				BUSHING PUSHER (E)	BUSHING ADAPTER (F)	REAR BUSH ASSY PLATE (G)	BUSHING INSTALLER (H)		
322	33472	N/A	2.312	35199	35205	25562	25546	33936	None
325	32437	N/A	2.519	35199	22769	25562	25546	33934	None
330	32441	N/A	2.677	35199	22769	25562	35204	33934	None
345	32441	N/A	2.996	32434	22787	25563	35204	33934	None
375	33474	N/A	3.710	32434	Not Req'd	25561	25546	33934	None
375	33474	N/A	3.71	32434	Not Req'd	25561	25546	33934	None
561	33472	N/A	2.312	35199	35205	25562	25546	33936	None
561	33471	1.774	2.621	32434	22769	25562	25546	33934	None
571	32441	N/A	2.621	35199	22769	25562	35204	33934	None
572	33471	1.898	2.812	32434	22787	25563	25546	33934	None
572	32441	N/A	2.621	32434	22769	25562	35204	33934	None
578	32441	N/A	2.940	32434	22787	25563	35204	33934	None
578	32441	N/A	2.937	32434	22787	25563	35204	33934	None
583	32441	N/A	2.621	35199	22769	25562	35204	33934	None
583	33471	1.788	2.618	32434	22787	25561	25546	33934	None
583	32441	2.024	2.996	32434	22771	25561	25546	33934	None

WTC Machinery
MPP 100 Tooling Chart

				MASTER PIN RMOVAL AND INSTALLATION					
MAKE	MODEL	COMMENTS	PITCH	PIN LENGTH	PIN DIA	FORCING PIN (A)	ALIGNING BUSHING (2)(B)		PILOT PIN ©
							REMOVAL	INSTALL	
CATERPILLAR	589		9.000	11.440	2.003	25551	22751	Not Req'd	Not Req'd
CATERPILLAR	589	PPR	9.000	10.770	2.003	25551	22751	Not Req'd	Not Req'd
CATERPILLAR	594		10.250	12.125	2.252	25501	Not Req'd	Not Req'd	Not Req'd
CATERPILLAR	931		6.125	5.989	1.129	200281	Not Req'd	Not Req'd	25504
CATERPILLAR	931	SALT	6.125	6.16	1.129	200281	Not Req'd	Not Req'd	25504
CATERPILLAR	931	Sealed	6.125	6.16	1.129	200281	Not Req'd	Not Req'd	25504
CATERPILLAR	933		6.125	5.989	1.129	200281	Not Req'd	Not Req'd	25504
CATERPILLAR	933		6.750	7.000	1.314	25499	Not Req'd	Not Req'd	25502
CATERPILLAR	935		6.125	5.989	1.129	200281	Not Req'd	Not Req'd	25504
CATERPILLAR	939		6.735	7.535	1.318	25499	Not Req'd	Not Req'd	25502
CATERPILLAR	941		6.735	7.220	1.315	25499	Not Req'd	Not Req'd	25502
CATERPILLAR	941	(9/16" Bolt)	6.735	7	1.314	25499	Not Req'd	Not Req'd	25502
CATERPILLAR	941	(5/8" Bolt)	6.735	7.22	1.315	25499	Not Req'd	Not Req'd	25502
CATERPILLAR	941		6.750	7.000	1.314	25499	Not Req'd	Not Req'd	25502
CATERPILLAR	943		6.750	7.000	1.314	25499	Not Req'd	Not Req'd	25502
CATERPILLAR	951		6.906	8.120	1.442	25500	Not Req'd	22779	Not Req'd

WTC Machinery
MPP 100 Tooling Chart

MODEL	ALIGNING ADAPTOR (D)	BUSHING ID	BUSHING OD	BUSHING REMOVAL		BUSHING INSTALL		REAR FORCING PIN (J)	SPECIAL TOOLING
				BUSHING PUSHER (E)	BUSHING ADAPTER (F)	REAR BUSH ASSY PLATE (G)	BUSHING INSTALLER (H)		
589	32441	N/A	3.220	32434	31658	25561	25546	33934	None
589	32441	N/A	3.220	32434	31658	25561	25546	33934	None
594	33474	2.274	3.375	32434	31658	25561	25546	33934	None
931	32435	1.150	1.850	35199	33471	N/A	N/A	33934	None
931	32435	N/A	1.85	35199	33471	35202	EITHER	33934	None
931	32435	N/A	1.85	35199	33471	35202	EITHER	33934	None
933	32435	1.150	1.850	35199	33471	N/A	EITHER	33934	None
933	33472	1.330	1.993	35199	35205	N/A	25546	33936	None
935	32435	1.150	1.850	35199	33471	N/A	EITHER	33934	None
939	22471	N/A	2.228	35199	35205	25562	25546	33936	None
941	22471	N/A	2.118	35199	35205	25562	25546	33936	None
941	22471	N/A	1.993	35199	35205	35202	25546	33936	None
941	22471	N/A	2.118	35199	35205	25562	25546	33936	None
941	33472	1.330	1.993	35199	35205	N/A	25546	33936	None
943	33472	1.330	1.993	35199	35205	N/A	25546	33936	None
951	33472	N/A	2.312	35199	35205		25546	33936	None

WTC Machinery
MPP 100 Tooling Chart

				MASTER PIN RMOVAL AND INSTALLATION					
MAKE	MODEL	COMMENTS	PITCH	PIN LENGTH	PIN DIA	FORCING PIN (A)	ALIGNING BUSHING (2)(B)		PILOT PIN ©
							REMOVAL	INSTALL	
CATERPILLAR	953		6.750	8.125	1.438	25500	22779	22779	Not Req'd
CATERPILLAR	955		6.750	7.000	1.314	25499	Not Req'd	Not Req'd	25502
CATERPILLAR	955	NEW	6.750	8.125	1.438	25500	22779	22779	Not Req'd
CATERPILLAR	955		8.000	9.000	1.750	25548	22777	22751	Not Req'd
CATERPILLAR	963		8.000	9.000	1.750	25548	22777	22751	Not Req'd
CATERPILLAR	973		8.500	9.813	1.877	25551	22751	22749	Not Req'd
CATERPILLAR	973		8.5	9.88	1.878	25551	22751	22749	Not Req'd
CATERPILLAR	977	OLD	6.750	8.125	1.438	25500	22779	22779	Not Req'd
CATERPILLAR	977	NEW	8.000	9.688	1.747	25548	22777	22751	Not Req'd
CATERPILLAR	977		8.500	9.813	1.877	25551	22751	22749	Not Req'd
CATERPILLAR	983		9.000	11.313	1.998	25551	22749	Not Req'd	Not Req'd
CATERPILLAR	5080		10.250	12.244	2.253	25501	Not Req'd	Not Req'd	Not Req'd
CATERPILLAR	5130					200281	Not Req'd	Not Req'd	25506
CATERPILLAR	D7	OLD	8.000	9.688	1.747	25548	22777	22751	Not Req'd
CATERPILLAR	14A		7.985	11.440	1.752	25548	22777	22751	Not Req'd
CATERPILLAR	17A		7.985	9.88	1.752	25548	22777	22751	Not Req'd

WTC Machinery
MPP 100 Tooling Chart

				BUSHING REMOVAL		BUSHING INSTALL			
MODEL	ALIGNING ADAPTOR (D)	BUSHING ID	BUSHING OD	BUSHING PUSHER (E)	BUSHING ADAPTER (F)	REAR BUSH ASSY PLATE (G)	BUSHING INSTALLER (H)	REAR FORCING PIN (J)	SPECIAL TOOLING
953	33472	1.458	2.118	35199	35205	N/A	25546	33936	None
955	33472	1.330	1.993	35199	35205	N/A	25546	33936	None
955	33472	1.458	2.118	35199	35205	N/A	25546	33936	None
955	33471	1.774	2.621	32434	22769	25562	25546	33934	None
963	33471	1.774	2.621	32434	22769	25562	25546	33934	None
973	33471	1.898	2.812	32434	22787	25563	25546	33934	None
973	32441	N/A	2.812	32434	22787	25563	35204	33934	None
977	33472	1.458	2.118	35199	35205	N/A	25546	33936	None
977	33471	1.773	2.621	32434	22769	25563	25546	33934	None
977	33471	1.898	2.812	32434	22787	25563	25546	33934	None
983	32441	2.024	2.996	32434	22771	25561	25546	33934	None
5080	33474	N/A	3.710	32434	Not Req'd	25561	25546	33934	None
5130	32435	N/A	4.330	32434	Not Req'd	25561	25546	33934	None
D7	33471	1.773	2.621	32434	22769	25563	25546	33934	None
14A	32441	N/A	2.621	35199	22769	25562	35204	33934	None
17A	32441	N/A	2.621	35199	22769	25562	35204	33934	None

WTC Machinery
MPP 100 Tooling Chart

				MASTER PIN RMOVAL AND INSTALLATION					
MAKE	MODEL	COMMENTS	PITCH	PIN LENGTH	PIN DIA	FORCING PIN (A)	ALIGNING BUSHING (2)(B)		PILOT PIN ©
							REMOVAL	INSTALL	
CATERPILLAR	215A		7.480	8.120	1.442	25500	Not Req'd	22779	Not Req'd
CATERPILLAR	225B	EXC	7.48	8.12	1.442	25500	Not Req'd	22779	Not Req'd
CATERPILLAR	231D		7.985	9.06	1.752	25548	22777	22751	Not Req'd
CATERPILLAR	235D	EXC	9	11.44	2.003	25551	22751	Not Req'd	Not Req'd
CATERPILLAR	245S		9.000	11.313	1.998	25551	22749	Not Req'd	Not Req'd
CATERPILLAR	307C		6.060	5.150	0.940	200281	Not Req'd	Not Req'd	25505
CATERPILLAR	315B		7.480	8.150	1.442	25500	Not Req'd	22779	Not Req'd
CATERPILLAR	315C		7.480	8.150	1.442	25500	Not Req'd	22779	Not Req'd
CATERPILLAR	318C		7.48	8.15	1.442	25500	Not Req'd	22779	Not Req'd
CATERPILLAR	320C		7.480	8.150	1.442	25500	Not Req'd	22779	Not Req'd
CATERPILLAR	322B		7.480	8.150	1.442	25500	Not Req'd	22779	Not Req'd
CATERPILLAR	322C		7.480	8.150	1.442	25500	Not Req'd	22779	Not Req'd
CATERPILLAR	330B		8.500	9.665	1.811	25551	22751	22749	Not Req'd
CATERPILLAR	345B		8.500	9.882	1.877	25551	22751	22749	Not Req'd
CATERPILLAR	345BL		8.500	9.882	1.877	25551	22751	22749	Not Req'd
CATERPILLAR	385B		10.250	13.188	2.253	25501	Not Req'd	Not Req'd	Not Req'd

WTC Machinery
MPP 100 Tooling Chart

				BUSHING REMOVAL		BUSHING INSTALL			
MODEL	ALIGNING ADAPTOR (D)	BUSHING ID	BUSHING OD	BUSHING PUSHER (E)	BUSHING ADAPTER (F)	REAR BUSH ASSY PLATE (G)	BUSHING INSTALLER (H)	REAR FORCING PIN (J)	SPECIAL TOOLING
215A	33472	N/A	2.312	35199	35205	25562	25546	33936	None
225B	33472	N/A	2.312	35199	35205	25562	25546	33936	None
231D	32441	N/A	2.621	35199	22769	25562	35204	33934	None
235D	32441	N/A	2.996	32434	22787	25563	35204	33934	None
245S	32441	2.024	2.996	32434	22771	25561	25546	33934	None
307C	32435	N/A	1.620	35199	33471	35205	35204	33934	None
315B	33472	N/A	3.120	35199	22771	25561	25546	33936	None
315C	33472	N/A	3.120	35199	22771	25561	25546	33936	None
318C	33472	N/A	3.12	35199	22771	25561	25546	33936	None
320C	33472	N/A	3.120	35199	22771	25561	25546	33936	None
322B	33472	N/A	3.120	35199	22771	25561	25546	33936	None
322C	33472	N/A	3.120	35199	22771	25561	25546	33936	None
330B	32441	N/A	2.677	35199	22769	25562	35204	33934	None
345B	32441	N/A	2.812	32434	22787	25563	35204	33934	None
345BL	32441	N/A	2.812	32434	22787	25563	35204	33934	None
385B	33474	N/A	3.371	32434	31658	25561	25546	33934	None

WTC Machinery
MPP 100 Tooling Chart

				MASTER PIN RMOVAL AND INSTALLATION					
MAKE	MODEL	COMMENTS	PITCH	PIN LENGTH	PIN DIA	FORCING PIN (A)	ALIGNING BUSHING (2)(B)		PILOT PIN ©
							REMOVAL	INSTALL	
CATERPILLAR	385B		10.25	13.188	2.253	25501	Not Req'd	Not Req'd	Not Req'd
CATERPILLAR	5080		10.25	12.244	2.253	25501	Not Req'd	Not Req'd	Not Req'd
CATERPILLAR	561H		6.735	7.535	1.318	25499	Not Req'd	Not Req'd	25502
CATERPILLAR	561H-HD		6.735	8.445	1.418	25500	Not Req'd	22779	Not Req'd
CATERPILLAR	571A		8.500	9.813	1.877	25551	22751	22749	Not Req'd
CATERPILLAR	572PL		8.000	9.688	1.747	25548	22777	22751	Not Req'd
CATERPILLAR	583R	PIPELAYER	8.500	9.880	1.878	25551	22751	22749	Not Req'd
CATERPILLAR	594		10.25	12.25	2.252	25501	Not Req'd	Not Req'd	Not Req'd
CATERPILLAR	671PL		6.750	8.125	1.438	25500	22779	22779	Not Req'd
CATERPILLAR	935B	Sealed	6.125	6.16	1.129	200281	Not Req'd	Not Req'd	25504
CATERPILLAR	935C		6.125	6.160	1.129	200281	Not Req'd	Not Req'd	25504
CATERPILLAR	935C	SALT	6.125	6.16	1.129	200281	Not Req'd	Not Req'd	25504
CATERPILLAR	951B		6.750	8.125	1.438	25500	22779	22779	Not Req'd
CATERPILLAR	951C		6.906	8.120	1.442	25500	Not Req'd	22779	Not Req'd
CATERPILLAR	955		7.985	9.06	1.752	25548	22777	22751	Not Req'd
CATERPILLAR	955C		6.750	7.000	1.314	25499	Not Req'd	Not Req'd	25502

WTC Machinery
MPP 100 Tooling Chart

				BUSHING REMOVAL		BUSHING INSTALL			
MODEL	ALIGNING ADAPTOR (D)	BUSHING ID	BUSHING OD	BUSHING PUSHER (E)	BUSHING ADAPTER (F)	REAR BUSH ASSY PLATE (G)	BUSHING INSTALLER (H)	REAR FORCING PIN (J)	SPECIAL TOOLING
385B	33474	N/A	3.371	32434	31658	25561	25546	33934	None
5080	33474	N/A	3.371	32434	31658	25561	25546	33934	None
561H	22471	N/A	2.336	35199	22769	25562	25546	33936	None
561H-HD	33472	N/A	2.336	35199	22769	25562	25546	33936	None
571A	33471	1.898	2.812	32434	22787	25563	25546	33934	None
572PL	33471	1.773	2.621	32434	22769	25563	25546	33934	None
583R	32441	N/A	2.940	32434	22787	25563	35204	33934	None
594	33474	N/A	3.371	32434	31658	25561	25546	33934	None
671PL	33472	1.458	2.118	35199	35205	N/A	25546	33936	None
935B	32435	N/A	1.85	35199	33471	35202	EITHER	33934	None
935C	32435	N/A	1.850	35199	33471	35202	EITHER	33934	None
935C	32435	N/A	1.85	35199	33471	35205	EITHER	33934	None
951B	33472	1.458	2.118	35199	35205	N/A	25546	33936	None
951C	33472	N/A	2.312	35199	35205	25562	25546	33936	None
955	32441	N/A	2.621	35199	22769	25562	35204	33934	None
955C	33472	1.330	1.993	35199	35205	N/A	25546	33936	None

WTC Machinery
MPP 100 Tooling Chart

				MASTER PIN RMOVAL AND INSTALLATION					
MAKE	MODEL	COMMENTS	PITCH	PIN LENGTH	PIN DIA	FORCING PIN (A)	ALIGNING BUSHING (2)(B)		PILOT PIN ©
							REMOVAL	INSTALL	
CATERPILLAR	955D		6.750	8.125	1.438	25500	22779	22779	Not Req'd
CATERPILLAR	955E		6.750	8.125	1.438	25500	22779	22779	Not Req'd
CATERPILLAR	955H		6.750	8.125	1.438	25500	22779	22779	Not Req'd
CATERPILLAR	955-HD		6.906	8.13	1.442	25500	Not Req'd	22779	Not Req'd
CATERPILLAR	955K		6.750	8.125	1.438	25500	22779	22779	Not Req'd
CATERPILLAR	955LD		6.750	7.000	1.314	25499	Not Req'd	Not Req'd	25502
CATERPILLAR	977E		8.000	9.688	1.747	25548	22777	22751	Not Req'd
CATERPILLAR	977H		8.000	9.688	1.747	25548	22777	22751	Not Req'd
CATERPILLAR	977K		8.000	9.688	1.747	25548	22777	22751	Not Req'd
CATERPILLAR	AP1050		6.125	6.160	1.129	200281	Not Req'd	Not Req'd	25504
CATERPILLAR	D10		10.25	12.25	2.252	25501	Not Req'd	Not Req'd	Not Req'd
CATERPILLAR	D10	PPR	10.25	11.97	2.252	25501	Not Req'd	Not Req'd	Not Req'd
CATERPILLAR	D10N		10.25	12.25	2.252	25501	Not Req'd	Not Req'd	Not Req'd
CATERPILLAR	D10N	PPR	10.25	11.97	2.252	25501	Not Req'd	Not Req'd	Not Req'd
CATERPILLAR	D10N		10.25	11.97	2.253	25501	Not Req'd	Not Req'd	Not Req'd
CATERPILLAR	D11		12.5	13.81	2.626	25553	Not Req'd	Not Req'd	Not Req'd

WTC Machinery
MPP 100 Tooling Chart

				BUSHING REMOVAL		BUSHING INSTALL			
MODEL	ALIGNING ADAPTOR (D)	BUSHING ID	BUSHING OD	BUSHING PUSHER (E)	BUSHING ADAPTER (F)	REAR BUSH ASSY PLATE (G)	BUSHING INSTALLER (H)	REAR FORCING PIN (J)	SPECIAL TOOLING
955D	33472	1.458	2.118	35199	35205	N/A	25546	33936	None
955E	33472	1.458	2.118	35199	35205	N/A	25546	33936	None
955H	33472	1.458	2.118	35199	35205	N/A	25546	33936	None
955-HD	33472	N/A	2.118	35199	35205	25562	25546	33936	None
955K	33472	1.458	2.118	35199	35205	N/A	25546	33936	None
955LD	33472	1.330	1.993	35199	35205	N/A	25546	33936	None
977E	33471	1.773	2.621	32434	22769	25563	25546	33934	None
977H	33471	1.773	2.621	32434	22769	25563	25546	33934	None
977K	33471	1.773	2.621	32434	22769	25563	25546	33934	None
AP1050	32435	N/A	1.850	35199	33471	35205	EITHER	33934	None
D10	33474	N/A	3.809	32434	Not Req'd	25561	25546	33934	None
D10	33474	N/A	3.809	32434	Not Req'd	25561	25546	33934	None
D10N	33474	N/A	3.557	32434	31658	25561	25546	33934	None
D10N	33474	N/A	3.557	32434	31658	25561	25546	33934	None
D10N	33474	N/A	3.557	32434	31658	25561	25546	33934	None
D11	Not Req'd	N/A	4.633	32434	Not Req'd	25561	25546	33934	None

WTC Machinery
MPP 100 Tooling Chart

				MASTER PIN RMOVAL AND INSTALLATION					
MAKE	MODEL	COMMENTS	PITCH	PIN LENGTH	PIN DIA	FORCING PIN (A)	ALIGNING BUSHING (2)(B)		PILOT PIN ©
							REMOVAL	INSTALL	
CATERPILLAR	D11N	PPR	12.25	11.97	2.252	25501	Not Req'd	Not Req'd	Not Req'd
CATERPILLAR	D11N		12.5	11.97	2.252	25501	Not Req'd	Not Req'd	Not Req'd
CATERPILLAR	D11R		12.5	11.97	2.252	25501	Not Req'd	Not Req'd	Not Req'd
CATERPILLAR	D2		6.125	6.156	1.127	200281	Not Req'd	Not Req'd	25504
CATERPILLAR	D3		6.125	5.989	1.129	200281	Not Req'd	Not Req'd	25504
CATERPILLAR	D3B		6.125	6.16	1.129	200281	Not Req'd	Not Req'd	25504
CATERPILLAR	D3C		6.125	6.16	1.129	200281	Not Req'd	Not Req'd	25504
CATERPILLAR	D4		6.750	7.000	1.314	25499	Not Req'd	Not Req'd	25502
CATERPILLAR	D4B		6.125	5.989	1.129	200281	Not Req'd	Not Req'd	25504
CATERPILLAR	D4C		6.125	5.989	1.129	200281	Not Req'd	Not Req'd	25504
CATERPILLAR	D4C		6.735	7	1.314	25499	Not Req'd	Not Req'd	25502
CATERPILLAR	D4C		6.125	6.16	1.129	200281	Not Req'd	Not Req'd	25504
CATERPILLAR	D4D		6.735	7.000	1.314	25499	Not Req'd	Not Req'd	25502
CATERPILLAR	D4G		6.125	5.989	1.129	200281	Not Req'd	Not Req'd	25504
CATERPILLAR	D4H		6.735	7.535	1.318	25499	Not Req'd	Not Req'd	25502
CATERPILLAR	D4H-HD		6.735	8.445	1.418	25500	Not Req'd	22779	Not Req'd

WTC Machinery
MPP 100 Tooling Chart

				BUSHING REMOVAL		BUSHING INSTALL			
MODEL	ALIGNING ADAPTOR (D)	BUSHING ID	BUSHING OD	BUSHING PUSHER (E)	BUSHING ADAPTER (F)	REAR BUSH ASSY PLATE (G)	BUSHING INSTALLER (H)	REAR FORCING PIN (J)	SPECIAL TOOLING
D11N	33474	N/A	3.557	32434	31658	25561	25546	33934	None
D11N	33474	N/A	3.557	32434	31658	25561	25546	33934	None
D11R	33474	N/A	3.557	32434	31658	25561	25546	33934	None
D2	32435	N/A	1.690	35199	33471	35205	35204	33934	None
D3	32435	1.150	1.850	35199	33471	N/A	EITHER	33934	None
D3B	32435	N/A	1.85	35199	33471	35205	EITHER	33934	None
D3C	32435	N/A	1.85	35199	33471	35202	EITHER	33934	None
D4	33472	1.330	1.993	35199	35205	N/A	25546	33936	None
D4B	32435	1.150	1.850	35199	33471	N/A	EITHER	33934	None
D4C	32435	1.150	1.850	35199	33471	N/A	EITHER	33934	None
D4C	22471	N/A	1.994	35199	35205	35202	25546	33936	None
D4C	32435	N/A	1.85	35199	33471	35202	EITHER	33934	None
D4D	22471	N/A	1.993	35199	35205	35202	25546	33936	None
D4G	32435	1.150	1.850	35199	33471	N/A	EITHER	33934	None
D4H	22471	N/A	2.228	35199	35205	25562	25546	33936	None
D4H-HD	33472	N/A	2.336	35199	22769	25562	25546	33936	None

WTC Machinery
MPP 100 Tooling Chart

				MASTER PIN RMOVAL AND INSTALLATION					
MAKE	MODEL	COMMENTS	PITCH	PIN LENGTH	PIN DIA	FORCING PIN (A)	ALIGNING BUSHING (2)(B)		PILOT PIN ©
							REMOVAL	INSTALL	
CATERPILLAR	D5		6.750	8.125	1.438	25500	22779	22779	Not Req'd
CATERPILLAR	D5	PRO	6.906	8.120	1.442	25500	Not Req'd	22779	Not Req'd
CATERPILLAR	D5	Sealed	6.906	8.12	1.442	25500	Not Req'd	22779	Not Req'd
CATERPILLAR	D5B		6.906	8.125	1.442	25500	Not Req'd	22779	Not Req'd
CATERPILLAR	D5C		6.735	7.535	1.318	25499	Not Req'd	Not Req'd	25502
CATERPILLAR	D5H		7.480	8.120	1.442	25500	Not Req'd	22779	Not Req'd
CATERPILLAR	D5H-HD		7.480	9.390	1.490	25500	Not Req'd	22779	Not Req'd
CATERPILLAR	D5M		6.735	7.535	1.318	25499	Not Req'd	Not Req'd	25502
CATERPILLAR	D6		6.750	8.125	1.438	25500	22779	22779	Not Req'd
CATERPILLAR	D6		7.985	9.060	1.752	25548	22777	22751	Not Req'd
CATERPILLAR	D6B		6.750	8.125	1.438	25500	22779	22779	Not Req'd
CATERPILLAR	D6C		8.000	9.000	1.750	25548	22777	22751	Not Req'd
CATERPILLAR	D6D		7.985	9.060	1.752	25548	22777	22751	Not Req'd
CATERPILLAR	D6H		7.985	9.060	1.530	25547	22779	22777	Not Req'd
CATERPILLAR	D6H-HD		7.985	10.315	1.753	25548	22777	22751	Not Req'd
CATERPILLAR	D6M		7.480	1.495	8.120	25553	Not Req'd	Not Req'd	Not Req'd

WTC Machinery
MPP 100 Tooling Chart

				BUSHING REMOVAL		BUSHING INSTALL			
MODEL	ALIGNING ADAPTOR (D)	BUSHING ID	BUSHING OD	BUSHING PUSHER (E)	BUSHING ADAPTER (F)	REAR BUSH ASSY PLATE (G)	BUSHING INSTALLER (H)	REAR FORCING PIN (J)	SPECIAL TOOLING
D5	33472	1.458	2.118	35199	35205	N/A	25546	33936	None
D5	33472	N/A	2.312	35199	35205	25562	25546	33936	None
D5	33472	N/A	2.312	35199	35205	25562	25546	33936	None
D5B	33472	N/A	2.312	35199	35205	25562	25546	33936	None
D5C	22471	N/A	2.280	35199	35205	25562	25546	33936	None
D5H	33472	N/A	2.413	35199	22769	25562	25546	33936	None
D5H-HD	32437	N/A	2.495	35199	22769	25562	25546	33934	None
D5M	22471	N/A	2.366	35199	22769	25562	25546	33936	None
D6	33472	1.458	2.118	35199	35205	N/A	25546	33936	None
D6	32441	N/A	2.621	35199	22769	25562	35204	33934	None
D6B	33472	1.458	2.118	35199	35205	N/A	25546	33936	None
D6C	33471	1.774	2.621	32434	22769	25562	25546	33934	None
D6D	32441	N/A	2.621	35199	22769	25562	35204	33934	None
D6H	32437	N/A	2.750	35199	35206	25563	35204	33934	None
D6H-HD	32441	N/A	2.864	35199	22787	25563	35204	33934	None
D6M	Not Req'd	N/A	2.495	35199	22769	25562	25546	33934	None

WTC Machinery
MPP 100 Tooling Chart

				MASTER PIN RMOVAL AND INSTALLATION					
MAKE	MODEL	COMMENTS	PITCH	PIN LENGTH	PIN DIA	FORCING PIN (A)	ALIGNING BUSHING (2)(B)		PILOT PIN ©
							REMOVAL	INSTALL	
CATERPILLAR	D6R		7.985	9.060	1.752	25548	22777	22751	Not Req'd
CATERPILLAR	D7C		7.985	9.880	1.752	25548	22777	22751	Not Req'd
CATERPILLAR	D7D		7.985	9.880	1.752	25548	22777	22751	Not Req'd
CATERPILLAR	D7E		7.985	9.880	1.877	25551	22751	22749	Not Req'd
CATERPILLAR	D7E		8.500	9.813	1.877	25551	22751	22749	Not Req'd
CATERPILLAR	D7F		7.985	9.880	1.877	25551	22751	22749	Not Req'd
CATERPILLAR	D7F		8.500	9.813	1.877	25551	22751	22749	Not Req'd
CATERPILLAR	D7G		7.985	9.880	1.877	25551	22751	22749	Not Req'd
CATERPILLAR	D7G		8.500	9.813	1.877	25551	22751	22749	Not Req'd
CATERPILLAR	D7G	Sealed	7.985	9.88	1.877	25551	22751	22749	Not Req'd
CATERPILLAR	D7G-LGP		8.5	9.88	1.878	25551	22751	22749	Not Req'd
CATERPILLAR	D7H		8.500	9.880	1.878	25551	22751	22749	Not Req'd
CATERPILLAR	D7H-HD		8.500	10.866	1.878	25551	22751	22749	Not Req'd
CATERPILLAR	D7N		8.500	9.813	1.877	25551	22751	22749	Not Req'd
CATERPILLAR	D7R		8.500	10.875	1.878	25551	22751	22749	Not Req'd
CATERPILLAR	D8		8.000	11.438	1.740	25548	22777	22751	Not Req'd

WTC Machinery
MPP 100 Tooling Chart

MODEL	ALIGNING ADAPTOR (D)	BUSHING ID	BUSHING OD	BUSHING REMOVAL		BUSHING INSTALL		REAR FORCING PIN (J)	SPECIAL TOOLING
				BUSHING PUSHER (E)	BUSHING ADAPTER (F)	REAR BUSH ASSY PLATE (G)	BUSHING INSTALLER (H)		
D6R	32441	N/A	2.864	35199	22787	25563	35204	33934	None
D7C	32441	N/A	2.621	35199	22769	25562	35204	33934	None
D7D	32441	N/A	2.621	35199	22769	25562	35204	33934	None
D7E	32441	N/A	2.812	32434	22787	25563	35204	33934	None
D7E	33471	1.898	2.812	32434	22787	25563	25546	33934	None
D7F	32441	N/A	2.812	32434	22787	25563	35204	33934	None
D7F	33471	1.898	2.812	32434	22787	25563	25546	33934	None
D7G	32441	N/A	2.812	32434	22787		35204	33934	None
D7G	33471	1.898	2.812	32434	22787	25563	25546	33934	None
D7G	32441	N/A	2.812	32434	22787	25563	35204	33934	None
D7G-LGP	32441	N/A	2.812	32434	22787	25563	35204	33934	None
D7H	32441	N/A	2.937	32434	22787	25563	35204	33934	None
D7H-HD	32441	N/A	3.085	32434	22771	25561	25546	33934	None
D7N	33471	1.898	2.812	32434	22787	25563	25546	33934	None
D7R	32441	N/A	3.085	32434	22771	25561	25546	33934	None
D8	33471	1.788	2.618	32434	22787	25561	25546	33934	None

WTC Machinery
MPP 100 Tooling Chart

				MASTER PIN RMOVAL AND INSTALLATION					
MAKE	MODEL	COMMENTS	PITCH	PIN LENGTH	PIN DIA	FORCING PIN (A)	ALIGNING BUSHING (2)(B)		PILOT PIN ©
							REMOVAL	INSTALL	
CATERPILLAR	D8D		8.000	11.438	1.740	25548	22777	22751	Not Req'd
CATERPILLAR	D8E		8.000	11.438	1.740	25548	22777	22751	Not Req'd
CATERPILLAR	D8F		8.000	11.438	1.740	25548	22777	22751	Not Req'd
CATERPILLAR	D8G		8.000	11.438	1.740	25548	22777	22751	Not Req'd
CATERPILLAR	D8H		9.000	11.313	1.998	25551	22749	Not Req'd	Not Req'd
CATERPILLAR	D8H	Sealed	9	11.44	2.003	25551	22751	Not Req'd	Not Req'd
CATERPILLAR	D8J		9.000	11.313	1.998	25551	22749	Not Req'd	Not Req'd
CATERPILLAR	D8K		9.000	11.313	1.998	25551	22749	Not Req'd	Not Req'd
CATERPILLAR	D8L		8.500	9.880	1.878	25551	22751	22749	Not Req'd
CATERPILLAR	D8N		8.500	9.880	1.878	25551	22751	22749	Not Req'd
CATERPILLAR	D8R		8.5	9.88	1.878	25551	22751	22749	Not Req'd
CATERPILLAR	D9		9.000	11.875	2.002	25551	22749	Not Req'd	Not Req'd
CATERPILLAR	D9		10.25	12.25	2.25	25501	Not Req'd	Not Req'd	Not Req'd
CATERPILLAR	D9D		10.250	12.125	2.252	25501	Not Req'd	Not Req'd	Not Req'd
CATERPILLAR	D9E		10.250	12.125	2.252	25501	Not Req'd	Not Req'd	Not Req'd
CATERPILLAR	D9G		10.250	12.125	2.252	25501	Not Req'd	Not Req'd	Not Req'd

WTC Machinery
MPP 100 Tooling Chart

				BUSHING REMOVAL		BUSHING INSTALL			
MODEL	ALIGNING ADAPTOR (D)	BUSHING ID	BUSHING OD	BUSHING PUSHER (E)	BUSHING ADAPTER (F)	REAR BUSH ASSY PLATE (G)	BUSHING INSTALLER (H)	REAR FORCING PIN (J)	SPECIAL TOOLING
D8D	33471	1.788	2.618	32434	22787	25561	25546	33934	None
D8E	33471	1.788	2.618	32434	22787	25561	25546	33934	None
D8F	33471	1.788	2.618	32434	22787	25561	25546	33934	None
D8G	33471	1.788	2.618	32434	22787	25561	25546	33934	None
D8H	32441	2.024	2.996	32434	22771	25561	25546	33934	None
D8H	32441	N/A	2.996	32434		25563	35204	33934	None
D8J	32441	2.024	2.996	32434	22771	25561	25546	33934	None
D8K	32441	2.024	2.996	32434	22771	25561	25546	33934	None
D8L	32441	N/A	2.940	32434	22787	25563	35204	33934	None
D8N	32441	N/A	2.940	32434	22787	25563	35204	33934	None
D8R	32441	N/A	2.94	32434	22787	25563	35204	33934	None
D9	32441	2.024	2.871	32434	22789	25561	25546	33934	None
D9	33474	N/A	3.371	32434	31658	25561	25546	33934	None
D9D	33474	2.274	3.375	32434	31658	25561	25546	33934	None
D9E	33474	2.274	3.375	32434	31658	25561	25546	33934	None
D9G	33474	2.274	3.375	32434	31658	25561	25546	33934	None

WTC Machinery
MPP 100 Tooling Chart

				MASTER PIN RMOVAL AND INSTALLATION					
MAKE	MODEL	COMMENTS	PITCH	PIN LENGTH	PIN DIA	FORCING PIN (A)	ALIGNING BUSHING (2)(B)		PILOT PIN ©
							REMOVAL	INSTALL	
CATERPILLAR	D9H	Sealed	10.25	12.25	2.252	25501	Not Req'd	Not Req'd	Not Req'd
CATERPILLAR	D9H	SALT	10.25	12.25	2.252	25501	Not Req'd	Not Req'd	Not Req'd
CATERPILLAR	D9L		9.000	11.875	2.002	25551	22749	Not Req'd	Not Req'd
CATERPILLAR	D9L	PPR	9	10.77	2.003	25551	22751	Not Req'd	Not Req'd
CATERPILLAR	D9N		9.45	10.98	2.003	25551	22751	Not Req'd	Not Req'd
CATERPILLAR	D9N	PPR	9.45	10.44	2.003	25551	22751	Not Req'd	Not Req'd
CATERPILLAR	D9R		9.45	10.98	2.003	25551	22751	Not Req'd	Not Req'd
CATERPILLAR	D9R	PPR	9.45	10.44	2.003	25551	22751	Not Req'd	Not Req'd
CATERPILLAR	E110B		6.75	7.01	1.319	25499	Not Req'd	Not Req'd	25502
CATERPILLAR	E120B		6.75	7.01	1.319	25499	Not Req'd	Not Req'd	25502
CATERPILLAR	E180		6.906	8.12	1.442	25500	Not Req'd	22779	Not Req'd
CATERPILLAR	E200B		7.48	8.125	1.443	25500	Not Req'd	22779	Not Req'd
CATERPILLAR	E240		7.48	8.125	1.443	25500	Not Req'd	22779	Not Req'd
CATERPILLAR	E300A		7.48	8.58	1.488	25500	Not Req'd	22779	Not Req'd
CATERPILLAR	E300B		8	9.65	1.75	25548	22777	22751	Not Req'd
CATERPILLAR	E450		8.5	10	1.873	25551	22751	22749	Not Req'd

WTC Machinery
MPP 100 Tooling Chart

				BUSHING REMOVAL		BUSHING INSTALL			
MODEL	ALIGNING ADAPTOR (D)	BUSHING ID	BUSHING OD	BUSHING PUSHER (E)	BUSHING ADAPTER (F)	REAR BUSH ASSY PLATE (G)	BUSHING INSTALLER (H)	REAR FORCING PIN (J)	SPECIAL TOOLING
D9H	33474	N/A	3.371	32434	31658	25561	25546	33934	None
D9H	33474	N/A	3.22	32434	31658	25561	25546	33934	None
D9L	32441	2.024	2.871	32434	22789	25561	25546	33934	None
D9L	32441	N/A	3.23	32434	31658	25561	25546	33934	None
D9N	32441	N/A	3.163	32434	22771	25561	25546	33934	None
D9N	32441	N/A	3.136	32434	22771	25561	25546	33934	None
D9R	32441	N/A	3.163	32434	22771	25561	25546	33934	None
D9R	32441	N/A	3.136	32434	22771	25561	25546	33934	None
E110B	22471	N/A	1.984	35199	35205	35205	EITHER	33936	None
E120B	22471	N/A	1.984	35199	35205	35202	EITHER	33936	None
E180	33472	N/A	2.31	35199	35205	25562	25546	33936	None
E200B	33472	N/A	2.311	35199	35205	25562	25546	33936	None
E240	33472	N/A	2.311	35199	35205	25562	25546	33936	None
E300A	32437	N/A	2.325	35199	22769	25562	25546	33936	None
E300B	32441	N/A	2.624	35199	22769	25562	35204	33934	None
E450	32441	N/A	2.809	35199	22787	25563	35204	33934	None

WTC Machinery
MPP 100 Tooling Chart

				MASTER PIN RMOVAL AND INSTALLATION					
MAKE	MODEL	COMMENTS	PITCH	PIN LENGTH	PIN DIA	FORCING PIN (A)	ALIGNING BUSHING (2)(B)		PILOT PIN ©
							REMOVAL	INSTALL	
CATERPILLAR	E70		5.315	5.51	0.945	200281	Not Req'd	Not Req'd	25505
CATERPILLAR	E70B		5.315	5.51	0.945	200281	Not Req'd	Not Req'd	25505
CATERPILLAR	EL180		6.906	8.12	1.442	25500	Not Req'd	22779	Not Req'd
CATERPILLAR	EL200B		7.48	8.125	1.443	25500	Not Req'd	22779	Not Req'd
CATERPILLAR	EL240		7.48	8.125	1.443	25500	Not Req'd	22779	Not Req'd
CATERPILLAR	EL300A/B		8	9.65	1.75	25548	22777	22751	Not Req'd
CATERPILLAR	FB227		7.985	9.06	1.752	25548	22777	22751	Not Req'd
CATERPILLAR	MHI 180-8		6.906	8.12	1.442	25500	Not Req'd	22779	Not Req'd
CATERPILLAR	MHI 180LC-8		6.906	8.12	1.442	25500	Not Req'd	22779	Not Req'd
CATERPILLAR	MHI 300LC-8		8	9.65	1.75	25548	22777	22751	Not Req'd
CATERPILLAR	PR450		6.125	6.16	1.129	200281	Not Req'd	Not Req'd	25504
CATERPILLAR	SF350		6.125	6.16	1.129	200281	Not Req'd	Not Req'd	25504
CATERPILLAR	TR225		6.125	6.16	1.129	200281	Not Req'd	Not Req'd	25504
DRESSER	150		6.5	6.69	1.374	25499	Not Req'd	Not Req'd	25502
DRESSER	175		7	7.87	1.625	25547	22779	22751	Not Req'd
DRESSER	500		6	5.36	1.125	200281	Not Req'd	Not Req'd	25504

WTC Machinery
MPP 100 Tooling Chart

			BUSHING REMOVAL		BUSHING INSTALL				
MODEL	ALIGNING ADAPTOR (D)	BUSHING ID	BUSHING OD	BUSHING PUSHER (E)	BUSHING ADAPTER (F)	REAR BUSH ASSY PLATE (G)	BUSHING INSTALLER (H)	REAR FORCING PIN (J)	SPECIAL TOOLING
E70	32435	N/A	1.614	35199	33471	35202	35204	33934	None
E70B	32435	N/A	1.614	3.5199	33471	35202	35204	33934	None
EL180	33472	N/A	2.31	35199	35205	25562	25546	33936	None
EL200B	33472	N/A	2.311	35199	35205	25562	25546	33936	None
EL240	33472	N/A	2.311	35199	35205	25562	25546	33936	None
EL300A/B	32441	N/A	2.624	35199	22769	25562	35204	33934	None
FB227	32441	N/A	2.621	35199	22769	25562	35204	33934	None
MHI 180-8	33472	N/A	2.31	35199	35205	25562	25546	33936	None
MHI 180LC-8	33472	N/A	2.31	35199	35205	25562	25546	33936	None
MHI 300LC-8	32441	N/A	2.624	35199	22769	25562	35204	33934	None
PR450	32435	N/A	1.85	35199	33471	35202	EITHER	33934	None
SF350	32435	N/A	1.85	35199	33471	35202	EITHER	33934	None
TR225	32435	N/A	1.85	35199	33471	35202	EITHER	33934	None
150	33472	N/A	2.053	35199	35205	25562	25546	33934	None
175	32437	N/A	2.364	35199	22769	25562	25546	33936	None
500	32435	N/A	1.656	35199	33471	35202	35204	33934	None

WTC Machinery
MPP 100 Tooling Chart

				MASTER PIN RMOVAL AND INSTALLATION					
MAKE	MODEL	COMMENTS	PITCH	PIN LENGTH	PIN DIA	FORCING PIN (A)	ALIGNING BUSHING (2)(B)		PILOT PIN ©
							REMOVAL	INSTALL	
DRESSER	100B		6	5.97	1.25	25498	Not Req'd	Not Req'd	25502
DRESSER	100C		6	6.5	1.25	25498	Not Req'd	Not Req'd	25502
DRESSER	100E		6	6.5	1.25	25498	Not Req'd	Not Req'd	25502
DRESSER	100G		6.49	6.69	1.314	25499	Not Req'd	Not Req'd	25502
DRESSER	125C		6.5	6.69	1.374	25499	Not Req'd	Not Req'd	25502
DRESSER	125E		6.5	6.69	1.374	25499	Not Req'd	Not Req'd	25502
DRESSER	125G		6.49	6.69	1.314	25499	Not Req'd	Not Req'd	25502
DRESSER	175B		7	7.87	1.625	25547	22779	22751	Not Req'd
DRESSER	175B		7.5	8.81	1.75	25548	22777	22751	Not Req'd
DRESSER	175C		7.5	8.81	1.75	25548	22777	22751	Not Req'd
DRESSER	250B		7.5	9.31	1.75	25548	22777	22751	Not Req'd
DRESSER	250C		7.5	9.31	1.75	25548	22777	22751	Not Req'd
DRESSER	500E		5.99	5.3	1.125	200281	Not Req'd	Not Req'd	25504
DRESSER	T340		6	4.75	1.01	200281	Not Req'd	Not Req'd	25505
DRESSER	T5		6	4.75	1.01	200281	Not Req'd	Not Req'd	25505
DRESSER	T6		6	5.97	1.25	25498	Not Req'd	Not Req'd	25502

WTC Machinery
MPP 100 Tooling Chart

MODEL	ALIGNING ADAPTOR (D)	BUSHING ID	BUSHING OD	BUSHING REMOVAL		BUSHING INSTALL		REAR FORCING PIN (J)	SPECIAL TOOLING
				BUSHING PUSHER (E)	BUSHING ADAPTER (F)	REAR BUSH ASSY PLATE (G)	BUSHING INSTALLER (H)		
100B	32435	N/A	1.8	35199	33471	35202	EITHER	33934	None
100C	32435	N/A	1.805	35199	33471	35202	EITHER	33934	None
100E	32435	N/A	1.8	35199	33471	35205	EITHER	33934	None
100G	22471	N/A	2.115	35199	35205	25562	25546	33934	None
125C	33472	N/A	2.053	35199	35205	25562	25546	33934	None
125E	33472	N/A	2.053	35199	35205	25562	25546	33934	None
125G	22471	N/A	2.115	35199	35205	25562	25546	33934	None
175B	32437	N/A	2.364	35199	22769	25562	25546	33936	None
175B	32441	N/A	2.614	35199	22769	25562	25546	33936	None
175C	32441	N/A	2.614	35199	22769	25562	25546	33936	None
250B	32441	N/A	2.614	35199	22769	25562	25546	33934	None
250C	32441	N/A	2.614	35199	22769	25562	25546	33934	None
500E	32435	N/A	1.675	35199	33471	35202	35204	33934	None
T340	32435	N/A	1.47	35199	32437	35202	35204	33934	None
T5	32435	N/A	1.47	35199	32437	35202	35204	33934	None
T6	32435	N/A	1.8	35199	33471	35202	EITHER	33934	None

WTC Machinery
MPP 100 Tooling Chart

				MASTER PIN RMOVAL AND INSTALLATION					
MAKE	MODEL	COMMENTS	PITCH	PIN LENGTH	PIN DIA	FORCING PIN (A)	ALIGNING BUSHING (2)(B)		PILOT PIN ©
							REMOVAL	INSTALL	
DRESSER	T7		6	6.5	1.25	25498	Not Req'd	Not Req'd	25502
DRESSER	TD12	SALT	7.5	8.03	1.5	25500	Not Req'd	22777	Not Req'd
DRESSER	TD12	Sealed	7.5	8.03	1.75	25548	22777	22751	Not Req'd
DRESSER	TD12A		7.49	8.03	1.5	25500	Not Req'd	22777	Not Req'd
DRESSER	TD12B		7.49	8.03	1.5	25500	Not Req'd	22777	Not Req'd
DRESSER	TD15B		7	7.87	1.625	25547	22779	22751	Not Req'd
DRESSER	TD15B		7.5	8.81	1.75	25548	22777	22751	Not Req'd
DRESSER	TD15C		7.5	8.81	1.75	25548	22777	22751	Not Req'd
DRESSER	TD15C		7.5	8.81	1.625	25547	22779	22751	Not Req'd
DRESSER	TD15C	LGP	7.5	8.81	1.625	25547	22779	22751	Not Req'd
DRESSER	TD15E	LGP	7.98	8.81	1.75	25548	22777	22751	Not Req'd
DRESSER	TD15E	SALT	7.98	8.81	1.75	25548	22777	22751	Not Req'd
DRESSER	TD15E	Sealed	7.98	8.81	1.75	25548	22777	22751	Not Req'd
DRESSER	TD20B		7.5	9.31	1.75	25548	22777	22751	Not Req'd
DRESSER	TD20C		7.5	9.31	1.75	25548	22777	22751	Not Req'd
DRESSER	TD20C		8.5	9.31	1.875	25551	22751	22749	Not Req'd

WTC Machinery
MPP 100 Tooling Chart

			BUSHING REMOVAL		BUSHING INSTALL				
MODEL	ALIGNING ADAPTOR (D)	BUSHING ID	BUSHING OD	BUSHING PUSHER (E)	BUSHING ADAPTER (F)	REAR BUSH ASSY PLATE (G)	BUSHING INSTALLER (H)	REAR FORCING PIN (J)	SPECIAL TOOLING
T7	32435	N/A	1.805	35199	33471	35202	EITHER	33934	None
TD12	32437	N/A	2.366	35199	22769	25562	25546	33936	None
TD12	32441	N/A	2.366	35199	22769	25562	25546	33936	None
TD12A	32437	N/A	2.366	35199	22769	25562	25546	33936	None
TD12B	32437	N/A	2.366	35199	22769	25562	25546	33936	None
TD15B	32437	N/A	2.364	35199	22769	25562	25546	33936	None
TD15B	32441	N/A	2.614	35199	22769	25562	25546	33936	None
TD15C	32441	N/A	2.614	35199	22769	25562	25546	33936	None
TD15C	32437	N/A	2.614	35199	22769	25562	25546	33936	None
TD15C	32437	N/A	2.614	35199	22769	25562	25546	33936	None
TD15E	32441	N/A	2.754	35199	35206	25563	35204	33936	None
TD15E	32441	N/A	2.754	35199	35206	25563	35204	33936	None
TD15E	32441	N/A	2.756	35199	35206	25563	35204	33936	None
TD20B	32441	N/A	2.614	35199	22769	25562	25546	33934	None
TD20C	32441	N/A	2.614	35199	22769	25562	25546	33934	None
TD20C	32441	N/A	2.862	35199	22787	25563	35204	33934	None

WTC Machinery
MPP 100 Tooling Chart

				MASTER PIN RMOVAL AND INSTALLATION					
MAKE	MODEL	COMMENTS	PITCH	PIN LENGTH	PIN DIA	FORCING PIN (A)	ALIGNING BUSHING (2)(B)		PILOT PIN ©
							REMOVAL	INSTALL	
DRESSER	TD20E		8.5	10.44	1.875	25551	22751	22749	Not Req'd
DRESSER	TD20E		8.5	10.43	1.875	25551	22751	22749	Not Req'd
DRESSER	TD20E	SPLIT	8.5	10.43	1.875	25551	22751	22749	Not Req'd
DRESSER	TD20G		8.5	10.43	1.875	25551	22751	22749	Not Req'd
DRESSER	TD20G	LGP	8.5	10.43	1.875	25551	22751	22749	Not Req'd
DRESSER	TD24		8.5	11	1.875	25551	22751	22749	Not Req'd
DRESSER	TD25B		8.5	11	1.875	25551	22751	22749	Not Req'd
DRESSER	TD25C		9.87	11	2.125	25501	Not Req'd	Not Req'd	Not Req'd
DRESSER	TD25E		9.87	11	2.125	25501	Not Req'd	Not Req'd	Not Req'd
DRESSER	TD25G		9.87	11	2.125	25501	Not Req'd	Not Req'd	Not Req'd
DRESSER	TD30		9.87	11	2.125	25501	Not Req'd	Not Req'd	Not Req'd
DRESSER	TD4		6	4.75	1.01	200281	Not Req'd	Not Req'd	25505
DRESSER	TD40	SPLIT	11.02	12.6	2.454	25553	Not Req'd	Not Req'd	Not Req'd
DRESSER	TD5		6	4.75	1.01	200281	Not Req'd	Not Req'd	25505
DRESSER	TD6		6	5.97	1.25	25498	Not Req'd	Not Req'd	25502
DRESSER	TD7C		6	6.5	1.25	25498	Not Req'd	Not Req'd	25502

WTC Machinery
MPP 100 Tooling Chart

				BUSHING REMOVAL		BUSHING INSTALL			
MODEL	ALIGNING ADAPTOR (D)	BUSHING ID	BUSHING OD	BUSHING PUSHER (E)	BUSHING ADAPTER (F)	REAR BUSH ASSY PLATE (G)	BUSHING INSTALLER (H)	REAR FORCING PIN (J)	SPECIAL TOOLING
TD20E	32441	N/A	2.866	35199	22787	25563	35204	33934	None
TD20E	32441	N/A	2.866	35199	22787	25563	35204	33934	None
TD20E	32441	N/A	2.866	35199	22787	25563	35204	33934	None
TD20G	32441	N/A	2.866	35199	22787	25563	35204	33934	None
TD20G	32441	N/A	2.866	35199	22787	25563	35204	33934	None
TD24	32441	N/A	2.864	35199	22787	25563	35204	33934	None
TD25B	32441	N/A	2.864	35199	22787	25563	35204	33934	None
TD25C	33474	N/A	3.239	32434	31658	25561	25546	33934	None
TD25E	33474	N/A	3.239	32434	31658	25561	25546	33934	None
TD25G	33474	N/A	3.239	32434	31658	25561	25546	33934	None
TD30	33474	N/A	3.239	32434	31658	25561	25546	33934	None
TD4	32435	N/A	1.47	35199	32437	35202	35204	33934	None
TD40	Not Req'd	N/A	3.772	32434	Not Req'd	25561	25546	33934	None
TD5	32435	N/A	1.47	35199	32437	35202	35204	33934	None
TD6	32435	N/A	1.8	35199	33471	35202	EITHER	33934	None
TD7C	32435	N/A	1.805	35199	33471	35202	EITHER	33934	None

WTC Machinery
MPP 100 Tooling Chart

				MASTER PIN RMOVAL AND INSTALLATION					
MAKE	MODEL	COMMENTS	PITCH	PIN LENGTH	PIN DIA	FORCING PIN (A)	ALIGNING BUSHING (2)(B)		PILOT PIN ©
							REMOVAL	INSTALL	
DRESSER	TD7E		6	6.5	1.25	25498	Not Req'd	Not Req'd	25502
DRESSER	TD7G		6.49	6.69	1.314	25499	Not Req'd	Not Req'd	25502
DRESSER	TD7H		6.49	6.69	1.312	25499	Not Req'd	Not Req'd	25502
DRESSER	TD8C		6.5	6.69	1.374	25499	Not Req'd	Not Req'd	25502
DRESSER	TD8E		6.5	6.69	1.374	25499	Not Req'd	Not Req'd	25502
DRESSER	TD8G		6.49	6.69	1.314	25499	Not Req'd	Not Req'd	25502
DRESSER	TD9B		6.5	6.69	1.374	25499	Not Req'd	Not Req'd	25502
FIAT	8		6.688	7.000	1.373	25499	Not Req'd	Not Req'd	25502
FIAT	10		6.938	7.875	1.451	25500	22779	22779	Not Req'd
FIAT	14		7.500	8.625	1.569	25547	22779	22777	Not Req'd
FIAT	31		11.281	12.953	2.374	25553	Not Req'd	Not Req'd	Not Req'd
FIAT	455		5.313	4.875	0.978	200281	Not Req'd	Not Req'd	25505
FIAT	505		5.313	4.875	0.978	200281	Not Req'd	Not Req'd	25505
FIAT	555		5.313	4.875	0.978	200281	Not Req'd	Not Req'd	25505
FIAT	650		6.000	6.500	1.246	25498	Not Req'd	Not Req'd	25504
FIAT	652		6	6.24	1.25	25498	Not Req'd	Not Req'd	25502

WTC Machinery
MPP 100 Tooling Chart

				BUSHING REMOVAL		BUSHING INSTALL			
MODEL	ALIGNING ADAPTOR (D)	BUSHING ID	BUSHING OD	BUSHING PUSHER (E)	BUSHING ADAPTER (F)	REAR BUSH ASSY PLATE (G)	BUSHING INSTALLER (H)	REAR FORCING PIN (J)	SPECIAL TOOLING
TD7E	32435	N/A	1.8	35199	33471	35202	EITHER	33934	None
TD7G	22471	N/A	2.115	35199	35205	25562	25546	33934	None
TD7H	22471	N/A	2.115	35199	35205	25562	25546	33934	None
TD8C	33472	N/A	2.053	35199	35205	25562	25546	33934	None
TD8E	33472	N/A	2.053	35199	35205	25562	25546	33934	None
TD8G	22471	N/A	2.115	35199	35205	25562	25546	33934	None
TD9B	33472	N/A	2.053	35199	35205	25562	25546	33934	None
8	33472	N/A	N/A	35199	Not Req'd	N/A	25546	33936	None
10	32437	N/A	N/A	35199	Not Req'd	N/A	25546	33936	None
14	32437	N/A	N/A	35199	Not Req'd	N/A	25546	33936	None
31	Not Req'd	N/A	3.876	32434	Not Req'd	25561	25546	33934	None
455	32437	0.989	1.453	35199	32437	35202	35204	33934	32425
505	32437	0.989	1.453	35199	32437	35202	35204	33934	32425
555	32437	0.989	1.453	35199	32437	35202	35204	33934	32425
650	32435	1.275	1.877	35199	33471	N/A	N/A	33934	None
652	32435	N/A	1.875	35199	33471	35202	EITHER	33934	None

WTC Machinery
MPP 100 Tooling Chart

				MASTER PIN RMOVAL AND INSTALLATION					
MAKE	MODEL	COMMENTS	PITCH	PIN LENGTH	PIN DIA	FORCING PIN (A)	ALIGNING BUSHING (2)(B)		PILOT PIN ©
							REMOVAL	INSTALL	
FIAT	653		6	6.24	1.25	25498	Not Req'd	Not Req'd	25502
FIAT	655		6	6.24	1.25	25498	Not Req'd	Not Req'd	25502
FIAT	655		6.313	5.875	1.175	25498	Not Req'd	Not Req'd	25504
FIAT	HD-11	OLD	7.000	8.125	1.558	25547	22779	22777	Not Req'd
FIAT	HD-11	OLD, SEALED	7.000	8.375	1.619	25547	22779	22777	Not Req'd
FIAT	HD-11GC	NEW	7.000	8.375	1.619	25547	22779	22777	Not Req'd
FIAT	HD-21	NEW	9.000	11.625	1.995	25551	22749	Not Req'd	Not Req'd
FIAT	100C		6.688	6.750	1.372	25499	Not Req'd	Not Req'd	25502
FIAT	10B		6.938	7.875	1.451	25500	22779	22779	Not Req'd
FIAT	11B		7.000	8.375	1.620	25547	22779	22751	Not Req'd
FIAT	12G		7.85	10.27	1.876	25551	22751	22749	Not Req'd
FIAT	12GB		7.85	10.27	1.876	25551	22751	22749	Not Req'd
FIAT	16B		7.875	10.250	1.872	25551	22751	22749	Not Req'd
FIAT	21C		9.000	11.625	2.031	25501	22749	Not Req'd	Not Req'd
FIAT	411C		5.313	4.875	0.978	200281	Not Req'd	Not Req'd	25505
FIAT	41B		11.281	14	2.622	25553	Not Req'd	Not Req'd	Not Req'd

WTC Machinery
MPP 100 Tooling Chart

				BUSHING REMOVAL		BUSHING INSTALL			
MODEL	ALIGNING ADAPTOR (D)	BUSHING ID	BUSHING OD	BUSHING PUSHER (E)	BUSHING ADAPTER (F)	REAR BUSH ASSY PLATE (G)	BUSHING INSTALLER (H)	REAR FORCING PIN (J)	SPECIAL TOOLING
653	32435	N/A	1.875	35199	33471	35202	EITHER	33934	None
655	32435	N/A	1.875	35199	33471	35202	EITHER	33934	None
655	22471	1.186	1.770	35199	33471	35202	35204	33934	32435
HD-11	32437	1.572	2.313	35199	35205	N/A	N/A	33936	None
HD-11	32437	1.631	2.500	35199	22769	N/A	N/A	33936	None
HD-11GC	32437	1.631	2.500	35199	22769	N/A	N/A	33936	None
HD-21	32441	2.021	3.040	32434	22789	25561	25546	33934	None
100C	22471	1.383	2.046	35199	35205	25562	35204	33934	33472
10B	32437	N/A	N/A	35199	Not Req'd	N/A	25546	33936	None
11B	32437	N/A	N/A	35199	Not Req'd	N/A	25546	33936	None
12G	32441	N/A	2.879	32434	22787	25563	35204	33934	None
12GB	32441	N/A	2.875	32434	22787	25563	35204	33934	None
16B	33471	N/A	N/A	35199	Not Req'd	N/A	25546	33934	None
21C	33471	N/A	N/A	32434	Not Req'd	N/A	25546	33934	None
411C	32437	0.989	1.453	35199	32437	35202	35204	33934	32425
41B	Not Req'd	N/A	3.998	32434	Not Req'd	25561	25546	33934	None

WTC Machinery
MPP 100 Tooling Chart

				MASTER PIN RMOVAL AND INSTALLATION					
MAKE	MODEL	COMMENTS	PITCH	PIN LENGTH	PIN DIA	FORCING PIN (A)	ALIGNING BUSHING (2)(B)		PILOT PIN ©
							REMOVAL	INSTALL	
FIAT	450M		6.313	5.875	1.175	25498	Not Req'd	Not Req'd	25504
FIAT	500M		6.313	5.875	1.175	25498	Not Req'd	Not Req'd	25504
FIAT	60C		6.688	6.750	1.372	25499	Not Req'd	Not Req'd	25502
FIAT	70C		6.688	6.750	1.372	25499	Not Req'd	Not Req'd	25502
FIAT	AD10		6.938	8.000	1.450	25500	22779	22779	Not Req'd
FIAT	AD10B		6.929	7.87	1.458	25500	Not Req'd	22779	Not Req'd
FIAT	AD12		7.48	8.66	1.577	25547	22779	22777	Not Req'd
FIAT	AD14		7.48	8.66	1.577	25547	22779	22777	Not Req'd
FIAT	AD14B		7.48	8.66	1.577	25547	22779	22777	Not Req'd
FIAT	AD18		8.500	10.000	1.872	25551	22751	22749	Not Req'd
FIAT	AD20		8.500	10.000	1.872	25551	22751	22749	Not Req'd
FIAT	AD4		5.313	4.875	0.978	200281	Not Req'd	Not Req'd	25505
FIAT	AD5		6.313	5.875	1.175	25498	Not Req'd	Not Req'd	25504
FIAT	AD6		6.688	6.750	1.372	25499	Not Req'd	Not Req'd	25502
FIAT	AD7		6.688	6.750	1.372	25499	Not Req'd	Not Req'd	25502
FIAT	AD7C		6.688	6.750	1.372	25499	Not Req'd	Not Req'd	25502

WTC Machinery
MPP 100 Tooling Chart

MODEL	ALIGNING ADAPTOR (D)	BUSHING ID	BUSHING OD	BUSHING REMOVAL		BUSHING INSTALL		REAR FORCING PIN (J)	SPECIAL TOOLING
				BUSHING PUSHER (E)	BUSHING ADAPTER (F)	REAR BUSH ASSY PLATE (G)	BUSHING INSTALLER (H)		
450M	22471	1.186	1.770	35199	33471	35202	35204	33934	32435
500M	22471	1.186	1.770	35199	33471	35202	35204	33934	32435
60C	22471	1.383	2.046	35199	35205	25562	35204	33934	33472
70C	22471	1.383	2.046	35199	35205	25562	35204	33934	33472
AD10	32437	1.462	2.284	35199	35205	25562	35204	33936	32437
AD10B	33472	N/A	2.287	35199	35205	25562	25546	33936	None
AD12	32437	N/A	2.366	35199	22769	25562	25546	33936	None
AD14	32437	N/A	2.366	35199	22769	25562	25546	33936	None
AD14B	32437	N/A		CHECK	32437	35205	35204	33936	None
AD18	33471	1.877	2.816	35199	35206	25563	35204	33934	33471
AD20	33471	1.877	2.816	35199	35206	25563	35204	33934	33471
AD4	32437	0.989	1.453	35199	32437	35202	35204	33934	32425
AD5	22471	1.186	1.770	35199	33471	35202	35204	33934	32435
AD6	22471	1.383	2.046	35199	35205	25562	35204	33934	33472
AD7	22471	1.383	2.046	35199	35205	25562	35204	33934	33472
AD7C	22471	1.383	2.046	35199	35205	25562	35204	33934	33472

WTC Machinery
MPP 100 Tooling Chart

				MASTER PIN RMOVAL AND INSTALLATION					
MAKE	MODEL	COMMENTS	PITCH	PIN LENGTH	PIN DIA	FORCING PIN (A)	ALIGNING BUSHING (2)(B)		PILOT PIN ©
							REMOVAL	INSTALL	
FIAT	AD8		6.692	7.13	1.377	25499	Not Req'd	22779	25502
FIAT	AD9		6.688	6.750	1.372	25499	Not Req'd	Not Req'd	25502
FIAT	B1		5.512	5.28	0.984	200281	Not Req'd	Not Req'd	25505
FIAT	BD10		6.938	8.000	1.450	25500	22779	22779	Not Req'd
FIAT	BD10B		6.929	7.87	1.458	25500	Not Req'd	22779	Not Req'd
FIAT	BD12		7.48	8.66	1.577	25547	22779	22777	Not Req'd
FIAT	BD14		7.48	8.66	1.577	25547	22779	22777	Not Req'd
FIAT	BD14B		7.48	8.66	1.577	25547	22779	22777	Not Req'd
FIAT	BD18		8.500	10.000	1.872	25551	22751	22749	Not Req'd
FIAT	BD20		8.500	10.000	1.872	25551	22751	22749	Not Req'd
FIAT	BD7		6.692	7.01	1.377	25499	Not Req'd	22779	25502
FIAT	BD7C		6.688	6.750	1.372	25499	Not Req'd	Not Req'd	25502
FIAT	BD8		6.692	7.13	1.377	25499	Not Req'd	22779	25502
FIAT	BD9		6.692	7.01	1.377	25499	Not Req'd	22779	25502
FIAT	DH-20		9.000	11.625	1.871	25551	22751	22749	Not Req'd
FIAT	EX200		6.906	8.346	1.442	25500	Not Req'd	22779	Not Req'd

WTC Machinery
MPP 100 Tooling Chart

MODEL	ALIGNING ADAPTOR (D)	BUSHING ID	BUSHING OD	BUSHING REMOVAL		BUSHING INSTALL		REAR FORCING PIN (J)	SPECIAL TOOLING
				BUSHING PUSHER (E)	BUSHING ADAPTER (F)	REAR BUSH ASSY PLATE (G)	BUSHING INSTALLER (H)		
AD8	33472		2.05	35199	35205	25562	25546	33936	None
AD9	22471	1.383	2.046	35199	35205	25562	35204	33934	33472
B1	32435		1.452	35199	32437	35205	35204	33934	None
BD10	32437	1.462	2.284	35199	35205	25562	35204	33936	32437
BD10B	33472	N/A	2.287	35199	35205	25562	25546	33936	None
BD12	32437	N/A	2.366	35199	22769	25562	25546	33936	None
BD14	32437	N/A	2.366	35199	22769	25562	25546	33936	None
BD14B	32437	N/A	2.364	35199	22769	25562	25546	33936	None
BD18	33471	1.877	2.816	35199	35206	25563	35204	33934	33471
BD20	33471	1.877	2.816	35199	35206	25563	35204	33934	33471
BD7	33472	N/A	2.043	35199	35205	25562	25546	33936	None
BD7C	22471	1.383	2.046	35199	35205	25562	35204	33934	33472
BD8	33472	N/A	2.05	35199	35205	25562	25546	33936	None
BD9	33472	N/A	2.043	35199	35205	25562	25546	33936	None
DH-20	33471	1.885	2.881	32434	22771	25563	25546	33934	None
EX200	33472	N/A	2.303	35199	35205	25562	25546	33936	None

WTC Machinery
MPP 100 Tooling Chart

				MASTER PIN RMOVAL AND INSTALLATION					
MAKE	MODEL	COMMENTS	PITCH	PIN LENGTH	PIN DIA	FORCING PIN (A)	ALIGNING BUSHING (2)(B)		PILOT PIN ©
							REMOVAL	INSTALL	
FIAT	EX400		8.5	10	1.875	25551	22751	22749	Not Req'd
FIAT	FA200		7.48	8.66	1.577	25547	22779	22777	Not Req'd
FIAT	FD14		7.48	8.66	1.577	25547	22779	22777	Not Req'd
FIAT	FD14D		7.48	8.66	1.577	25547	22779	22777	Not Req'd
FIAT	FD14E		7.48	8.66	1.577	25547	22779	22777	Not Req'd
FIAT	FD20	SALT	8.503	9.9	1.88	25551	22751	22749	Not Req'd
FIAT	FD20	Unsealed	8.503	9.84	1.873	25551	22751	22749	Not Req'd
FIAT	FD30		9.000	11.625	2.031	25501	22749	Not Req'd	Not Req'd
FIAT	FD30	SALT	9.035	11.65	2.036	25501	Not Req'd	Not Req'd	Not Req'd
FIAT	FD40		11.25	12.95	2.373	25553	Not Req'd	Not Req'd	Not Req'd
FIAT	FD40B		11.25	12.95	2.373	25553	Not Req'd	Not Req'd	Not Req'd
FIAT	FD5		6.299	6.42	1.26	25498	Not Req'd	Not Req'd	25502
FIAT	FD5		6.299	6.46	1.142	200281	Not Req'd	Not Req'd	25504
FIAT	FD50		11.281	14	2.622	25553	Not Req'd	Not Req'd	Not Req'd
FIAT	FD7		6.299	6.42	1.26	25498	Not Req'd	Not Req'd	25502
FIAT	FD7		6.299	6.46	1.142	200281	Not Req'd	Not Req'd	25504

WTC Machinery
MPP 100 Tooling Chart

MODEL	ALIGNING ADAPTOR (D)	BUSHING ID	BUSHING OD	BUSHING REMOVAL		BUSHING INSTALL		REAR FORCING PIN (J)	SPECIAL TOOLING
				BUSHING PUSHER (E)	BUSHING ADAPTER (F)	REAR BUSH ASSY PLATE (G)	BUSHING INSTALLER (H)		
EX400	32441	N/A	2.81	35199	22787	25563	35204	33934	None
FA200	32437	N/A	2.364	35199	22769	25562	25546	33936	None
FD14	32437	N/A	2.364	35199	22769	25562	25546	33936	None
FD14D	32437	N/A	2.364	35199	22769	25562	25546	33936	None
FD14E	32437	N/A		CHECK	32437	35205	35204	33936	None
FD20	32441	N/A	2.811	32434	22787	25563	35204	33934	None
FD20	32441	N/A	2.819	35199	22787	25563	35204	33934	None
FD30	33471	N/A	N/A	32434	Not Req'd	N/A	25546	33934	None
FD30	33474	N/A	3.194	32434	22771	25561	25546	33934	None
FD40	Not Req'd	N/A	3.88	32434	Not Req'd	25561	25546	33934	None
FD40B	Not Req'd	N/A	3.876	32434	Not Req'd	25561	25546	33934	None
FD5	32435	N/A	2.01	35199	35205	25562	25546	33934	None
FD5	32435	N/A	1.772	35199	33471	35202	EITHER	33934	None
FD50	Not Req'd	N/A	4.112	32434	Not Req'd	25561	25546	33934	None
FD7	32435	N/A	2.01	35199	35205	25562	25546	33934	None
FD7	32435	N/A	1.772	35199	33471	35205	EITHER	33934	None

WTC Machinery
MPP 100 Tooling Chart

				MASTER PIN RMOVAL AND INSTALLATION					
MAKE	MODEL	COMMENTS	PITCH	PIN LENGTH	PIN DIA	FORCING PIN (A)	ALIGNING BUSHING (2)(B)		PILOT PIN ©
							REMOVAL	INSTALL	
FIAT	FD9		6.692	7.17	1.382	25499	Not Req'd	22779	25502
FIAT	FE16		6.692	7.165	1.377	25499	Not Req'd	22779	25502
FIAT	FE18		6.692	7.165	1.377	25499	Not Req'd	22779	25502
FIAT	FE20		6.692	7.165	1.377	25499	Not Req'd	22779	25502
FIAT	FE20LC		6.692	7.165	1.377	25499	Not Req'd	22779	25502
FIAT	FE8LC		6.692	7.165	1.377	25499	Not Req'd	22779	25502
FIAT	FH120		6.692	7.165	1.377	25499	Not Req'd	22779	25502
FIAT	FH150		6.692	7.165	1.377	25499	Not Req'd	22779	25502
FIAT	FH150LC		6.692	7.165	1.377	25499	Not Req'd	22779	25502
FIAT	FH200		6.929	8.031	1.458	25500	Not Req'd	22779	Not Req'd
FIAT	FH200LC		6.929	8.031	1.458	25500	Not Req'd	22779	Not Req'd
FIAT	FL10		6.938	8.000	1.450	25500	22779	22779	Not Req'd
FIAT	FL12		7.48	8.66	1.577	25547	22779	22777	Not Req'd
FIAT	FL14		7.48	8.66	1.577	25547	22779	22777	Not Req'd
FIAT	FL14B		7.48	8.66	1.577	25547	22779	22777	Not Req'd
FIAT	FL14C		7.48	8.66	1.577	25547	22779	22777	Not Req'd

WTC Machinery
MPP 100 Tooling Chart

			BUSHING REMOVAL		BUSHING INSTALL				
MODEL	ALIGNING ADAPTOR (D)	BUSHING ID	BUSHING OD	BUSHING PUSHER (E)	BUSHING ADAPTER (F)	REAR BUSH ASSY PLATE (G)	BUSHING INSTALLER (H)	REAR FORCING PIN (J)	SPECIAL TOOLING
FD9	33472	N/A	2.085	35199	35205	25562	25546	33936	None
FE16	33472	N/A	2.047	35199	35205	25562	25546	33936	None
FE18	33472	N/A		CHECK	32437	35205	35204	33936	None
FE20	33472	N/A	2.047	35199	35205	25562	25546	33936	None
FE20LC	33472	N/A	2.047	35199	35205	25562	25546	33936	None
FE8LC	33472	N/A	2.047	35199	35205	25562	25546	33936	None
FH120	33472	N/A	2.047	35199	35205	25562	25546	33936	None
FH150	33472	N/A	2.047	35199	35205	25562	25546	33936	None
FH150LC	33472	N/A	2.047	35199	35205	25562	25546	33936	None
FH200	33472	N/A	2.284	35199	35205	25562	25546	33936	None
FH200LC	33472	N/A	2.284	35199	35205	25562	25546	33936	None
FL10	32437	1.462	2.284	35199	35205	25562	35204	33936	32437
FL12	32437	N/A	2.366	35199	22769	25562	25546	33936	None
FL14	32437	N/A	2.366	35199	22769	25562	25546	33936	None
FL14B	32437	N/A	2.366	35199	22769	25562	25546	33936	None
FL14C	32437	N/A	2.366	35199	22769	25562	25546	33936	None

WTC Machinery
MPP 100 Tooling Chart

				MASTER PIN RMOVAL AND INSTALLATION					
MAKE	MODEL	COMMENTS	PITCH	PIN LENGTH	PIN DIA	FORCING PIN (A)	ALIGNING BUSHING (2)(B)		PILOT PIN ©
							REMOVAL	INSTALL	
FIAT	FL20	SALT	8.503	9.9	1.88	25551	22751	22749	Not Req'd
FIAT	FL20	Unsealed	8.503	9.84	1.873	25551	22751	22749	Not Req'd
FIAT	FL4C		5.313	4.875	0.978	200281	Not Req'd	Not Req'd	25505
FIAT	FL4D		5.512	5.28	0.984	200281	Not Req'd	Not Req'd	25505
FIAT	FL4L		5.512	5.28	0.984	200281	Not Req'd	Not Req'd	25505
FIAT	FL5	SALT	6.299	6.42	1.26	25498	Not Req'd	Not Req'd	25502
FIAT	FL5	Unsealed	6.299	6.46	1.142	200281	Not Req'd	Not Req'd	25504
FIAT	FL5B	SALT	6.299	6.42	1.26	25498	Not Req'd	Not Req'd	25502
FIAT	FL6		6.299	6.1	1.181	25498	Not Req'd	Not Req'd	25504
FIAT	FL6		6.313	5.875	1.175	25498	Not Req'd	Not Req'd	25504
FIAT	FL7		6.688	6.750	1.372	25499	Not Req'd	Not Req'd	25502
FIAT	FL7		6.692	7.01	1.377	25499	Not Req'd	22779	25502
FIAT	FL7/B		6.299	6.42	1.26	25498	Not Req'd	Not Req'd	25502
FIAT	FL8		6.688	6.750	1.372	25499	Not Req'd	Not Req'd	25502
FIAT	FL8C		6.692	7.01	1.377	25499	Not Req'd	22779	25502
FIAT	FL9		6.692	7.13	1.377	25499	Not Req'd	22779	25502

WTC Machinery
MPP 100 Tooling Chart

				BUSHING REMOVAL		BUSHING INSTALL			
MODEL	ALIGNING ADAPTOR (D)	BUSHING ID	BUSHING OD	BUSHING PUSHER (E)	BUSHING ADAPTER (F)	REAR BUSH ASSY PLATE (G)	BUSHING INSTALLER (H)	REAR FORCING PIN (J)	SPECIAL TOOLING
FL20	32441	N/A	2.811	32434	22787	25563	35204	33934	None
FL20	32441	N/A	2.819	35199	22787	25563	35204	33934	None
FL4C	32437	0.989	1.453	35199	32437	35202	35204	33934	32425
FL4D	32435	N/A	1.452	35199	32437	35202	35204	33934	None
FL4L	32435	N/A	1.452	35199	32437	35202	35204	33934	None
FL5	32435	N/A	2.01	35199	35205	25562	25546	33934	None
FL5	32435	N/A	1.772	35199	33471	35202	EITHER	33934	None
FL5B	32435	N/A	2.01	35199	35205	25562	25546	33934	None
FL6	32435	N/A	1.767	35199	33471	35202	EITHER	33934	None
FL6	22471	1.186	1.770	35199	33471	35202	35204	33934	32435
FL7	22471	1.383	2.046	35199	35205	25562	35204	33934	33472
FL7	33472	N/A	2.043	35199	35205	25562	25546	33936	None
FL7/B	32435	N/A	2.01	35199	35205	25562	25546	33934	None
FL8	22471	1.383	2.046	35199	35205	25562	35204	33934	33472
FL8C	33472	N/A	2.043	35199	35205	25562	25546	33936	None
FL9	33472	N/A	2.05	35199	35205	25562	25546	33936	None

WTC Machinery
MPP 100 Tooling Chart

				MASTER PIN RMOVAL AND INSTALLATION					
MAKE	MODEL	COMMENTS	PITCH	PIN LENGTH	PIN DIA	FORCING PIN (A)	ALIGNING BUSHING (2)(B)		PILOT PIN ©
							REMOVAL	INSTALL	
FIAT	FP120		11.25	12.95	2.373	25553	Not Req'd	Not Req'd	Not Req'd
FIAT	H3		6	5.84	1.253	25498	Not Req'd	Not Req'd	25502
FIAT	H4		6	5.84	1.253	25498	Not Req'd	Not Req'd	25502
FIAT	HD10		7.85	8.37	1.753	25548	22777	22751	Not Req'd
FIAT	HD11		7	8.14	1.562	25547	22779	22777	Not Req'd
FIAT	HD11/B		7	8.4	1.622	25547	22779	22751	Not Req'd
FIAT	HD-115		7.000	8.375	1.619	25547	22779	22777	Not Req'd
FIAT	HD-11B		7.000	8.375	1.619	25547	22779	22777	Not Req'd
FIAT	HD11E		7	8.14	1.562	25547	22779	22777	Not Req'd
FIAT	HD-11E		7.000	8.375	1.619	25547	22779	22777	Not Req'd
FIAT	HD-11EC		7.000	8.375	1.619	25547	22779	22777	Not Req'd
FIAT	HD-11EP		7.000	8.375	1.619	25547	22779	22777	Not Req'd
FIAT	HD11G		7	8.14	1.562	25547	22779	22777	Not Req'd
FIAT	HD-11G		7.000	8.125	1.558	25547	22779	22777	Not Req'd
FIAT	HD-11GC		7.000	8.125	1.558	25547	22779	22777	Not Req'd
FIAT	HD12G		7.875	10.250	1.871	25551	22751	22749	Not Req'd

WTC Machinery
MPP 100 Tooling Chart

				BUSHING REMOVAL		BUSHING INSTALL			
MODEL	ALIGNING ADAPTOR (D)	BUSHING ID	BUSHING OD	BUSHING PUSHER (E)	BUSHING ADAPTER (F)	REAR BUSH ASSY PLATE (G)	BUSHING INSTALLER (H)	REAR FORCING PIN (J)	SPECIAL TOOLING
FP120	Not Req'd	N/A	3.876	32434	Not Req'd	25561	25546	33934	None
H3	32435	N/A	1.75	35199	33471	35202	EITHER	33934	None
H4	32435	N/A	1.75	35199	33471	35202	EITHER	33934	None
HD10	32441	N/A	2.5	35199	22769	25562	25546	33936	None
HD11	32437	N/A	2.315	35199	35205	25562	25546	33936	None
HD11/B	32437	N/A	2.5	35199	22769	25562	25546	33936	None
HD-115	32437	1.631	2.500	35199	22769	N/A	N/A	33936	None
HD-11B	32437	1.631	2.500	35199	22769	N/A	N/A	33936	None
HD11E	32437	N/A	2.315	35199	35205	25562	25546	33936	None
HD-11E	32437	1.631	2.500	35199	22769	N/A	N/A	33936	None
HD-11EC	32437	1.631	2.500	35199	22769	N/A	N/A	33936	None
HD-11EP	32437	1.631	2.500	35199	22769	N/A	N/A	33936	None
HD11G	32437	N/A	2.315	35199	35205	25562	25546	33936	None
HD-11G	32437	1.572	2.313	35199	35205	N/A	N/A	33936	None
HD-11GC	32437	1.572	2.313	35199	35205	N/A	N/A	33936	None
HD12G	33471	1.885	2.881	32434	22771	25563	25546	33934	None

WTC Machinery
MPP 100 Tooling Chart

				MASTER PIN RMOVAL AND INSTALLATION					
MAKE	MODEL	COMMENTS	PITCH	PIN LENGTH	PIN DIA	FORCING PIN (A)	ALIGNING BUSHING (2)(B)		PILOT PIN ©
							REMOVAL	INSTALL	
FIAT	HD14		7.85	9.67	1.878	25551	22751	22749	Not Req'd
FIAT	HD15		7.85	9.33	1.751	25548	22777	22751	Not Req'd
FIAT	HD-15		7.875	9.313	1.746	25548	22777	22751	Not Req'd
FIAT	HD-16	NO SEALS	7.875	9.313	1.746	25548	22777	22751	Not Req'd
FIAT	HD-16		7.875	10.250	1.871	25551	22751	22749	Not Req'd
FIAT	HD16	Sealed	7.85	10.27	1.876	25551	22751	22749	Not Req'd
FIAT	HD16	Unsealed	7.85	9.33	1.751	25548	22777	22751	Not Req'd
FIAT	HD16B		7.85	10.27	1.876	25551	22751	22749	Not Req'd
FIAT	HD16B		7.875	10.250	1.871	25551	22751	22749	Not Req'd
FIAT	HD-16D		7.875	10.250	1.871	25551	22751	22749	Not Req'd
FIAT	HD-16DC		7.875	10.250	1.871	25551	22751	22749	Not Req'd
FIAT	HD-16DD		7.875	10.250	1.871	25551	22751	22749	Not Req'd
FIAT	HD19		9	11.66	1.876	25551	22751	22749	Not Req'd
FIAT	HD-19		9.000	11.625	1.871	25551	22751	22749	Not Req'd
FIAT	HD20		9	11.66	1.876	25551	22751	22749	Not Req'd
FIAT	HD21		9	11.66	1.876	25551	22751	22749	Not Req'd

WTC Machinery
MPP 100 Tooling Chart

				BUSHING REMOVAL		BUSHING INSTALL			
MODEL	ALIGNING ADAPTOR (D)	BUSHING ID	BUSHING OD	BUSHING PUSHER (E)	BUSHING ADAPTER (F)	REAR BUSH ASSY PLATE (G)	BUSHING INSTALLER (H)	REAR FORCING PIN (J)	SPECIAL TOOLING
HD14	32441	N/A	2.75	32434	35206	25563	35204	33934	None
HD15	32441	N/A	2.623	35199	22769	25562	35204	33934	None
HD-15	33471	1.775	2.624	32434	22769	25562	25546	33934	None
HD-16	33471	1.775	2.624	32434	22769	25562	25546	33934	None
HD-16	33471	1.885	2.881	32434	22771	25563	25546	33934	None
HD16	32441	N/A	2.879	32434	22787	25563	35204	33934	None
HD16	32441	N/A	2.623	35199	22769	25562	35204	33934	None
HD16B	32441	N/A	2.875	32434	22787	25563	35204	33934	None
HD16B	33471	1.885	2.881	32434	22771	25563	25546	33934	None
HD-16D	33471	1.885	2.881	32434	22771	25563	25546	33934	None
HD-16DC	33471	1.885	2.881	32434	22771	25563	25546	33934	None
HD-16DD	33471	1.885	2.881	32434	22771	25563	25546	33934	None
HD19	32441	N/A	2.879	32434	22787	25563	35204	33934	None
HD-19	33471	1.885	2.881	32434	22771	25563	25546	33934	None
HD20	32441	N/A	2.879	32434	22787	25563	35204	33934	None
HD21	32441	N/A	2.879	32434	22787	25563	35204	33934	None

WTC Machinery
MPP 100 Tooling Chart

				MASTER PIN RMOVAL AND INSTALLATION					
MAKE	MODEL	COMMENTS	PITCH	PIN LENGTH	PIN DIA	FORCING PIN (A)	ALIGNING BUSHING (2)(B)		PILOT PIN ©
							REMOVAL	INSTALL	
FIAT	HD-21	OLD	9.000	11.625	1.871	25551	22751	22749	Not Req'd
FIAT	HD-21b	NEW	9.000	11.625	1.871	25551	22751	22749	Not Req'd
FIAT	HD21B		9	11.66	1.876	25551	22751	22749	Not Req'd
FIAT	HD21C		9.035	11.66	2.036	25501	Not Req'd	Not Req'd	Not Req'd
FIAT	HD21P		9	11.66	1.876	25551	22751	22749	Not Req'd
FIAT	HD3		6	5.84	1.253	25498	Not Req'd	Not Req'd	25502
FIAT	HD31	SALT	11.25	12.95	2.373	25553	Not Req'd	Not Req'd	Not Req'd
FIAT	HD31	Unsealed	11.25	12.95	2.373	25553	Not Req'd	Not Req'd	Not Req'd
FIAT	HD-4		6.000	6.500	1.246	25498	Not Req'd	Not Req'd	25504
FIAT	HD4		6	6.24	1.25	25498	Not Req'd	Not Req'd	25502
FIAT	HD41	Sealed	11.25	12.95	2.373	25553	Not Req'd	Not Req'd	Not Req'd
FIAT	HD41	Unsealed	11.25	12.95	2.373	25553	Not Req'd	Not Req'd	Not Req'd
FIAT	HD41B		11.25	14	2.623	25553	Not Req'd	Not Req'd	Not Req'd
FIAT	HD5		7.85	8.37	1.753	25548	22777	22751	Not Req'd
FIAT	HD-5		6.500	6.875	1.379	25499	Not Req'd	22779	25502
FIAT	HD5		6.5	6.91	1.376	25499	Not Req'd	22779	25502

WTC Machinery
MPP 100 Tooling Chart

				BUSHING REMOVAL		BUSHING INSTALL			
MODEL	ALIGNING ADAPTOR (D)	BUSHING ID	BUSHING OD	BUSHING PUSHER (E)	BUSHING ADAPTER (F)	REAR BUSH ASSY PLATE (G)	BUSHING INSTALLER (H)	REAR FORCING PIN (J)	SPECIAL TOOLING
HD-21	33471	1.885	2.881	32434	22771	25563	35204	33934	None
HD-21b	33471	1.900	3.040	32434	22771	25561	25546	33934	None
HD21B	32441	N/A	3.044	32434	22771	25561	25546	33934	None
HD21C	33474	N/A	3.194	32434	22771	25561	25546	33934	None
HD21P	32441	N/A	2.875	32434	22787	25563	35204	33934	None
HD3	32435	N/A	1.75	35199	33471	35205	EITHER	33934	None
HD31	Not Req'd	N/A	3.876	32434	Not Req'd	25561	25546	33934	None
HD31	Not Req'd	N/A	3.88	32434	Not Req'd	25561	25546	33934	None
HD-4	32435	1.275	1.877	35199	33471	N/A	EITHER	33934	None
HD4	32435	N/A	1.875	35199	33471	35202	EITHER	33934	None
HD41	Not Req'd	N/A	3.876	32434	Not Req'd	25561	25546	33934	None
HD41	Not Req'd	N/A	3.88	32434	Not Req'd	25561	25546	33934	None
HD41B	Not Req'd	N/A	3.998	32434	Not Req'd	25561	25546	33934	None
HD5	32441	N/A	2.5	35199	22769	25562	25546	33936	None
HD-5	33472	1.400	2.000	35199	35205	N/A	25546	33934	None
HD5	33472	N/A	2.005	35199	35205	25562	25546	33934	None

WTC Machinery
MPP 100 Tooling Chart

				MASTER PIN RMOVAL AND INSTALLATION					
MAKE	MODEL	COMMENTS	PITCH	PIN LENGTH	PIN DIA	FORCING PIN (A)	ALIGNING BUSHING (2)(B)		PILOT PIN ©
							REMOVAL	INSTALL	
FIAT	HD50		11.25	14	2.623	25553	Not Req'd	Not Req'd	Not Req'd
FIAT	HD50		11.25	14	2.622	25553	Not Req'd	Not Req'd	Not Req'd
FIAT	HD6		6.5	6.91	1.376	25499	Not Req'd	22779	25502
FIAT	HD-6		6.500	6.875	1.379	25499	Not Req'd	22779	25502
FIAT	HD-6A		6.500	6.875	1.379	25499	Not Req'd	22779	25502
FIAT	HD-6B		6.500	6.875	1.379	25499	Not Req'd	22779	25502
FIAT	HD-6E		6.500	6.875	1.379	25499	Not Req'd	22779	25502
FIAT	HD-6EP		6.500	6.875	1.379	25499	Not Req'd	22779	25502
FIAT	HD-6G		6.500	6.875	1.379	25499	Not Req'd	22779	25502
FIAT	HD7		6.5	7.51	1.736	25548	22777	22751	Not Req'd
FIAT	HD7		6.5	8.14	1.563	25547	22779	22777	Not Req'd
FIAT	HD7G		7	8.14	1.562	25547	22779	22777	Not Req'd
FIAT	HD-7GB		7.000	8.125	1.558	25547	22779	22777	Not Req'd
FIAT	HD7G-B		7	8.14	1.562	25547	22779	22777	Not Req'd
FIAT	HD9		7	8.14	1.562	25547	22779	22777	Not Req'd
FIAT	HD-9		7.000	8.125	1.558	25547	22779	22777	Not Req'd

WTC Machinery
MPP 100 Tooling Chart

				BUSHING REMOVAL		BUSHING INSTALL			
MODEL	ALIGNING ADAPTOR (D)	BUSHING ID	BUSHING OD	BUSHING PUSHER (E)	BUSHING ADAPTER (F)	REAR BUSH ASSY PLATE (G)	BUSHING INSTALLER (H)	REAR FORCING PIN (J)	SPECIAL TOOLING
HD50	Not Req'd	N/A	3.998	32434	Not Req'd	25561	25546	33934	None
HD50	Not Req'd	N/A	4.112	32434	Not Req'd	25561	25546	33934	None
HD6	33472	N/A	2.005	35199	35205	25562	25546	33934	None
HD-6	33472	1.400	2.000	35199	35205	N/A	25546	33934	None
HD-6A	33472	1.400	2.000	35199	35205	N/A	25546	33934	None
HD-6B	33472	1.400	2.000	35199	35205	N/A	25546	33934	None
HD-6E	33472	1.400	2.000	35199	35205	N/A	25546	33934	None
HD-6EP	33472	1.400	2.000	35199	35205	N/A	25546	33934	None
HD-6G	33472	1.400	2.000	35199	35205	N/A	25546	33934	None
HD7	32441	N/A	2	35199	35205	25562	25546	33936	None
HD7	32437	N/A	2.315	35199	35205	25562	25546	33936	None
HD7G	32437	N/A	2.331	35199	22769	25562	25546	33936	None
HD-7GB	32437	1.572	2.313	35199	35205	N/A	25546	33936	None
HD7G-B	32437	N/A	2.315	35199	35205	25562	25546	33936	None
HD9	32437	N/A	2.315	35199	35205	25562	25546	33936	None
HD-9	32437	1.572	2.313	35199	35205	N/A	25546	33936	None

WTC Machinery
MPP 100 Tooling Chart

				MASTER PIN RMOVAL AND INSTALLATION					
MAKE	MODEL	COMMENTS	PITCH	PIN LENGTH	PIN DIA	FORCING PIN (A)	ALIGNING BUSHING (2)(B)		PILOT PIN ©
							REMOVAL	INSTALL	
FIAT	K		6.5	7.51	1.736	25548	22777	22751	Not Req'd
FIAT	KO		6.5	7.51	1.736	25548	22777	22751	Not Req'd
FIAT	S11		6.692	7.165	1.377	25499	Not Req'd	22779	25502
FIAT	S9		6.692	7.165	1.377	25499	Not Req'd	22779	25502
FIAT	SL11		6.692	7.165	1.377	25499	Not Req'd	22779	25502
FIAT	SL9		6.692	7.165	1.377	25499	Not Req'd	22779	25502
FIAT	UH801		12.5	14.37	2.756	25553	Not Req'd	Not Req'd	Not Req'd
FOWLER	33 Challenger		8.000	10.625	1.750	25548	22777	22751	Not Req'd
FOWLER	33 Marshall		8.000	9.750	1.751	25548	22777	22751	Not Req'd
FOWLER	75 Marshall	NO COUPLING	6.750	8.250	1.308	25499	Not Req'd	Not Req'd	25502
HANOMAG	K-15		8.000	10.250	1.740	25548	22777	22751	Not Req'd
HITACHI	EX100		6.736	7.283	1.315	25499	Not Req'd	Not Req'd	25502
HITACHI	EX1100		10.25	12.578	2.29	25553	Not Req'd	Not Req'd	Not Req'd
HITACHI	EX120		6.736	7.283	1.315	25499	Not Req'd	Not Req'd	25502
HITACHI	EX1200-5		10.25	12.578	2.29	25553	Not Req'd	Not Req'd	Not Req'd
HITACHI	EX90		6.736	7.283	1.315	25499	Not Req'd	Not Req'd	25502

WTC Machinery
MPP 100 Tooling Chart

				BUSHING REMOVAL		BUSHING INSTALL			
MODEL	ALIGNING ADAPTOR (D)	BUSHING ID	BUSHING OD	BUSHING PUSHER (E)	BUSHING ADAPTER (F)	REAR BUSH ASSY PLATE (G)	BUSHING INSTALLER (H)	REAR FORCING PIN (J)	SPECIAL TOOLING
K	32441	N/A	2	35199	35205	25562	25546	33936	None
KO	32441	N/A	2	35199	35205	25562	25546	33936	None
S11	33472	N/A	2.047	35199	35205	25562	25546	33936	None
S9	33472	N/A	2.047	35199	35205	25562	25546	33936	None
SL11	33472	N/A	2.047	35199	35205	25562	25546	33936	None
SL9	33472	N/A	2.047	35199	35205	25562	25546	33936	None
UH801	Not Req'd	N/A	4.252	32434	Not Req'd	25561	25546	33934	None
33 Challenger	33471	1.775	2.629	32434	22769	25562	25546	33934	None
33 Marshall	33471	1.750	2.625	32434	22769	25562	25546	33934	None
75 Marshall	33472	1.306	2.000	35199	N/A	N/A	25546	33936	None
K-15	33471	1.775	2.621	32434	22769	22562	25546	33934	None
EX100	22471	N/A	1.315	35199	32437	35205	35204	33936	None
EX1100	33474	N/A	3.54	32434	31658	25561	25546	33934	None
EX120	22471	N/A	1.991	35199	35205	35205	25546	33936	None
EX1200-5	33474	N/A	3.54	32434	31658	25561	25546	33934	None
EX90	22471	N/A	1.991	35199	35205	35202	25546	33936	None

WTC Machinery
MPP 100 Tooling Chart

				MASTER PIN RMOVAL AND INSTALLATION					
MAKE	MODEL	COMMENTS	PITCH	PIN LENGTH	PIN DIA	FORCING PIN (A)	ALIGNING BUSHING (2)(B)		PILOT PIN ©
							REMOVAL	INSTALL	
INTERTRAC	150	LDR	6.500	6.688	1.367	25499	Not Req'd	Not Req'd	25502
INTERTRAC	175	LDR	7.000	7.875	1.617	25547	22779	22777	Not Req'd
INTERTRAC	100C		6.000	6.500	1.243	25498	Not Req'd	Not Req'd	25504
INTERTRAC	100E	LDR	6.000	6.500	1.243	25498	Not Req'd	Not Req'd	25504
INTERTRAC	125C	LDR	6.500	6.688	1.367	25499	Not Req'd	Not Req'd	25502
INTERTRAC	125E	LDR	6.500	6.688	1.367	25499	Not Req'd	Not Req'd	25502
INTERTRAC	175B		7.500	8.688	1.742	25548	22777	22751	Not Req'd
INTERTRAC	175C		7.500	8.688	1.742	25548	22777	22751	Not Req'd
INTERTRAC	250-B	LDR	7.500	8.688	1.742	25548	22777	22751	Not Req'd
INTERTRAC	250-C		8.500	11.000	1.865	25551	22751	22749	Not Req'd
INTERTRAC	TD-14		7.000	7.875	1.485	25500	22779	22779	Not Req'd
INTERTRAC	TD-14A		7.000	7.875	1.485	25500	22779	22779	Not Req'd
INTERTRAC	TD-14B		7.000	7.875	1.485	25500	22779	22779	Not Req'd
INTERTRAC	TD-15	OLD	7.000	7.875	1.485	25500	22779	22779	Not Req'd
INTERTRAC	TD-15	NEW	7.000	7.875	1.617	25547	22779	22777	Not Req'd
INTERTRAC	TD15B		7.000	7.875	1.617	25547	22779	22777	Not Req'd

WTC Machinery
MPP 100 Tooling Chart

				BUSHING REMOVAL		BUSHING INSTALL			
MODEL	ALIGNING ADAPTOR (D)	BUSHING ID	BUSHING OD	BUSHING PUSHER (E)	BUSHING ADAPTER (F)	REAR BUSH ASSY PLATE (G)	BUSHING INSTALLER (H)	REAR FORCING PIN (J)	SPECIAL TOOLING
150	33472	1.385	2.051	35199	35205	N/A	25546	33934	None
175	32437	1.636	2.364	35199	22769	N/A	25546	33936	None
100C	32435	1.259	1.801	35199	33471	N/A	EITHER	33934	None
100E	32435	1.259	1.801	35199	33471	N/A	EITHER	33934	None
125C	33472	1.385	2.051	35199	35205	N/A	25546	33934	None
125E	33472	1.385	2.051	35199	35205	N/A	25546	33934	None
175B	33471	1.760	2.614	32434	22769	25562	25546	33936	None
175C	33471	1.760	2.614	32434	22769	25562	25546	33936	None
250-B	33471	1.760	2.614	32434	22769	25562	25546	33936	None
250-C	33471	1.894	2.864	32434	22787	25563	25546	33934	None
TD-14	32437	1.510	2.239	35199	35205	N/A	25546	33936	None
TD-14A	32437	1.510	2.239	35199	35205	N/A	25546	33936	None
TD-14B	32437	1.510	2.239	35199	35205	N/A	25546	33936	None
TD-15	32437	1.510	2.239	35199	35205	N/A	25546	33936	None
TD-15	32437	1.636	2.364	35199	22769	N/A	25546	33936	None
TD15B	32437	1.636	2.364	35199	22769	N/A	25546	33936	None

WTC Machinery
MPP 100 Tooling Chart

				MASTER PIN RMOVAL AND INSTALLATION					
MAKE	MODEL	COMMENTS	PITCH	PIN LENGTH	PIN DIA	FORCING PIN (A)	ALIGNING BUSHING (2)(B)		PILOT PIN ©
							REMOVAL	INSTALL	
INTERTRAC	TD-15B		7.500	8.688	1.742	25548	22777	22751	Not Req'd
INTERTRAC	TD-15C		7.500	8.688	1.742	25548	22777	22751	Not Req'd
INTERTRAC	TD-18		7.500	9.813	1.735	25548	22777	22751	Not Req'd
INTERTRAC	TD-20		7.500	9.813	1.735	25548	22777	22751	Not Req'd
INTERTRAC	TD20-B		7.500	8.688	1.742	25548	22777	22751	Not Req'd
INTERTRAC	TD-20C		8.500	11.000	1.865	25551	22751	22749	Not Req'd
INTERTRAC	TD-20E		8.500	11.000	1.865	25551	22751	22749	Not Req'd
INTERTRAC	TD-24		8.500	11.000	1.865	25551	22751	22749	Not Req'd
INTERTRAC	TD-25	OLD	8.500	11.000	1.865	25551	22751	22749	Not Req'd
INTERTRAC	TD-25B		8.500	11.000	1.865	25551	22751	22749	Not Req'd
INTERTRAC	TD-25B	NEW	9.875	11.000	2.115	25501	22749	Not Req'd	Not Req'd
INTERTRAC	TD25C		9.875	11.000	2.115	25501	22749	Not Req'd	Not Req'd
INTERTRAC	TD-30		9.875	11.000	2.115	25501	22749	Not Req'd	Not Req'd
INTERTRAC	TD-6		6.000	6.500	1.243	25498	Not Req'd	Not Req'd	25504
INTERTRAC	TD-7C		6.000	6.500	1.243	25498	Not Req'd	Not Req'd	25504
INTERTRAC	TD-7E		6.000	6.500	1.243	25498	Not Req'd	Not Req'd	25504

WTC Machinery
MPP 100 Tooling Chart

MODEL	ALIGNING ADAPTOR (D)	BUSHING ID	BUSHING OD	BUSHING REMOVAL		BUSHING INSTALL		REAR FORCING PIN (J)	SPECIAL TOOLING
				BUSHING PUSHER (E)	BUSHING ADAPTER (F)	REAR BUSH ASSY PLATE (G)	BUSHING INSTALLER (H)		
TD-15B	33471	1.760	2.614	32434	22769	25562	25546	33936	None
TD-15C	33471	1.760	2.614	32434	22769	25562	25546	33936	None
TD-18	33471	1.760	2.489	32434	22769	25562	25546	33934	None
TD-20	33471	1.760	2.489	32434	22769	25562	25546	33934	None
TD20-B	33471	1.760	2.614	32434	22769	25562	25546	33936	None
TD-20C	33471	1.894	2.864	32434	22787	25563	25546	33934	None
TD-20E	33471	1.894	2.864	32434	22787	25563	25546	33934	None
TD-24	33471	1.894	2.864	32434	22787	25563	25546	33934	None
TD-25	33471	1.894	2.864	32434	22787	25563	25546	33934	None
TD-25B	33471	1.894	2.864	32434	22787	25563	25546	33934	None
TD-25B	32441	2.144	3.239	32434	22789	25561	25546	33934	None
TD25C	32441	2.144	3.239	32434	22789	25561	25546	33934	None
TD-30	32441	2.144	3.239	32434	22789	25561	25546	33934	None
TD-6	32435	1.259	1.801	35199	33471	N/A	EITHER	33934	None
TD-7C	32435	1.259	1.801	35199	33471	N/A	EITHER	33934	None
TD-7E	32435	1.259	1.801	35199	33471	N/A	EITHER	33934	None

WTC Machinery
MPP 100 Tooling Chart

				MASTER PIN RMOVAL AND INSTALLATION					
MAKE	MODEL	COMMENTS	PITCH	PIN LENGTH	PIN DIA	FORCING PIN (A)	ALIGNING BUSHING (2)(B)		PILOT PIN ©
							REMOVAL	INSTALL	
INTERTRAC	TD-8C		6.500	6.688	1.367	25499	Not Req'd	Not Req'd	25502
INTERTRAC	TD-8E		6.500	6.688	1.367	25499	Not Req'd	Not Req'd	25502
INTERTRAC	TD9		6.500	6.688	1.367	25499	Not Req'd	Not Req'd	25502
INTERTRAC	TD9-B		6.500	6.688	1.367	25499	Not Req'd	Not Req'd	25502
JOHN DEERE	291		6.125	6.456	1.181	25498	Not Req'd	Not Req'd	25504
JOHN DEERE	350		5.750	5.380	1.186	25498	Not Req'd	Not Req'd	25504
JOHN DEERE	370		8.5	10	1.873	25551	22751	22749	Not Req'd
JOHN DEERE	440		5.75	5.47	1	200281	Not Req'd	Not Req'd	25505
JOHN DEERE	450		6.290	6.100	1.374	25499	Not Req'd	Not Req'd	25502
JOHN DEERE	455		6.290	6.100	1.374	25499	Not Req'd	Not Req'd	25502
JOHN DEERE	490		6.734	6.97	1.317	25499	Not Req'd	Not Req'd	25502
JOHN DEERE	550		6.290	6.100	1.374	25499	Not Req'd	Not Req'd	25502
JOHN DEERE	555		6.290	6.100	1.374	25499	Not Req'd	Not Req'd	25502
JOHN DEERE	590		6.75	7.598	1.366	25499	Not Req'd	Not Req'd	25502
JOHN DEERE	650		6.290	6.100	1.374	25499	Not Req'd	Not Req'd	25502
JOHN DEERE	655		6.909	8.11	1.44	25500	Not Req'd	22779	Not Req'd

WTC Machinery
MPP 100 Tooling Chart

				BUSHING REMOVAL		BUSHING INSTALL			
MODEL	ALIGNING ADAPTOR (D)	BUSHING ID	BUSHING OD	BUSHING PUSHER (E)	BUSHING ADAPTER (F)	REAR BUSH ASSY PLATE (G)	BUSHING INSTALLER (H)	REAR FORCING PIN (J)	SPECIAL TOOLING
TD-8C	33472	1.385	2.051	35199	35205	N/A	25546	33934	None
TD-8E	33472	1.385	2.051	35199	35205	N/A	25546	33934	None
TD9	33472	1.385	2.051	35199	35205	N/A	25546	33934	None
TD9-B	33472	1.385	2.051	35199	35205	N/A	25546	33934	None
291	32435	N/A	1.85	35199	33471	35205	EITHER	33934	None
350	32435	1.190	1.750	35199	33471	N/A	EITHER	33934	None
370	32441	N/A	2.809	35199	22787	25563	35204	33934	None
440	32435	N/A	1.56	35199	32437	35205	35204	33934	None
450	33472	1.387	2.128	35199	35205	N/A	25546	33934	None
455	33472	1.387	2.128	35199	35205	N/A	25546	33934	None
490	22471	N/A	1.99	35199	35205	35205	25546	33934	None
550	33472	1.387	2.128	35199	35205	N/A	25546	33934	None
555	33472	1.387	2.128	35199	35205	N/A	25546	33934	None
590	22471	N/A	2.116	35199	35205	25562	25546	33936	None
650	33472	1.387	2.128	35199	35205	N/A	25546	33934	None
655	33472	N/A	2.314	35199	35205	25562	25546	33936	None

WTC Machinery
MPP 100 Tooling Chart

				MASTER PIN RMOVAL AND INSTALLATION					
MAKE	MODEL	COMMENTS	PITCH	PIN LENGTH	PIN DIA	FORCING PIN (A)	ALIGNING BUSHING (2)(B)		PILOT PIN ©
							REMOVAL	INSTALL	
JOHN DEERE	690		6.734	7.000	1.314	25499	Not Req'd	Not Req'd	25502
JOHN DEERE	750		6.909	6.150	1.437	25500	22779	22779	Not Req'd
JOHN DEERE	755		6.909	6.150	1.437	25500	22779	22779	Not Req'd
JOHN DEERE	790		7.480	8.583	1.496	25500	22779	22779	Not Req'd
JOHN DEERE	792		8.000	9.646	1.750	25548	22777	22751	Not Req'd
JOHN DEERE	850		7.988	8.976	1.748	25548	22777	22751	Not Req'd
JOHN DEERE	855		8.500	9.950	1.872	25551	22751	22749	Not Req'd
JOHN DEERE	890		8.500	9.950	1.872	25551	22751	22749	Not Req'd
JOHN DEERE	892		8.500	9.950	1.872	25551	22751	22749	Not Req'd
JOHN DEERE	990		8.500	9.950	1.872	25551	22751	22749	Not Req'd
JOHN DEERE	1280		6.9	8.11	1.439	25500	Not Req'd	22779	Not Req'd
JOHN DEERE	2010		5.75	5.47	1	200281	Not Req'd	Not Req'd	25505
JOHN DEERE	1050C		8.5	10.31	2	25551	22751	Not Req'd	Not Req'd
JOHN DEERE	1050J		8.5	10.31	2	25551	22751	Not Req'd	Not Req'd
JOHN DEERE	1150D		6.678	8.11	1.44	25500	Not Req'd	22779	Not Req'd
JOHN DEERE	1155D		6.678	8.11	1.44	25500	Not Req'd	22779	Not Req'd

WTC Machinery
MPP 100 Tooling Chart

				BUSHING REMOVAL		BUSHING INSTALL			
MODEL	ALIGNING ADAPTOR (D)	BUSHING ID	BUSHING OD	BUSHING PUSHER (E)	BUSHING ADAPTER (F)	REAR BUSH ASSY PLATE (G)	BUSHING INSTALLER (H)	REAR FORCING PIN (J)	SPECIAL TOOLING
690	33472	1.327	1.993	35199	35205	N/A	25546	33936	None
750	33472	1.449	2.316	35199	35205	N/A	25546	33934	None
755	33472	1.449	2.316	35199	35205	N/A	25546	33934	None
790	32437	1.512	2.323	35199	35205	N/A	25546	33936	None
792	33471	1.765	2.624	35199	22769	N/A	35204	33934	None
850	33471	1.750	2.626	32434	22769	25562	25546	33936	None
855	33471	1.897	2.813	32434	22787	25563	25546	33934	33471
890	33471	1.897	2.813	32434	22787	25563	25546	33934	33471
892	33471	1.897	2.813	32434	22787	25563	25546	33934	33471
990	33471	1.897	2.813	32434	22787	25563	25546	33934	33471
1280	33472	N/A	2.313	35199	35205	25562	25546	33936	None
2010	32435	N/A	1.56	35199	32437	35202	35204	33934	None
1050C	32441	N/A	3	32434	22787	25561	35204	33934	None
1050J	32441	N/A	3	32434	22787	25561	35204	33934	None
1150D	33472	N/A	2.314	35199	35205	25562	25546	33936	None
1155D	33472	N/A	2.314	35199	35205	25562	25546	33936	None

WTC Machinery
MPP 100 Tooling Chart

				MASTER PIN RMOVAL AND INSTALLATION					
MAKE	MODEL	COMMENTS	PITCH	PIN LENGTH	PIN DIA	FORCING PIN (A)	ALIGNING BUSHING (2)(B)		PILOT PIN ©
							REMOVAL	INSTALL	
JOHN DEERE	190E		6.063	6.102	1.19	25498	Not Req'd	Not Req'd	25504
JOHN DEERE	2010C		5.750	5.380	1.186	25498	Not Req'd	Not Req'd	25504
JOHN DEERE	270CLC		8.5	9.52	1.76	25548	22777	22751	Not Req'd
JOHN DEERE	290D		6.125	6.456	1.181	25498	Not Req'd	Not Req'd	25504
JOHN DEERE	330CLC		8.5	9.52	1.76	25548	22777	22751	Not Req'd
JOHN DEERE	330LC		8.5	9.52	1.76	25548	22777	22751	Not Req'd
JOHN DEERE	350B		5.75	5.47	1.192	25498	Not Req'd	Not Req'd	25504
JOHN DEERE	350C		5.75	5.47	1.192	25498	Not Req'd	Not Req'd	25504
JOHN DEERE	350D		5.75	5.38	1.192	25498	Not Req'd	Not Req'd	25504
JOHN DEERE	400G		5.75	5.38	1.192	25498	Not Req'd	Not Req'd	25504
JOHN DEERE	420C		5.75	5.47	1	200281	Not Req'd	Not Req'd	25505
JOHN DEERE	450C		6.290	6.100	1.374	25499	Not Req'd	Not Req'd	25502
JOHN DEERE	450C	Recessed	6.29	6.08	1.374	25499	Not Req'd	Not Req'd	25502
JOHN DEERE	450C	Sealed	6.29	6.2	1.374	25499	Not Req'd	Not Req'd	25502
JOHN DEERE	450D	Sealed	6.29	6.36	1.26	25498	Not Req'd	Not Req'd	25502
JOHN DEERE	450D	SALT	6.29	6.36	1.26	25498	Not Req'd	Not Req'd	25502

WTC Machinery
MPP 100 Tooling Chart

MODEL	ALIGNING ADAPTOR (D)	BUSHING ID	BUSHING OD	BUSHING REMOVAL		BUSHING INSTALL		REAR FORCING PIN (J)	SPECIAL TOOLING
				BUSHING PUSHER (E)	BUSHING ADAPTER (F)	REAR BUSH ASSY PLATE (G)	BUSHING INSTALLER (H)		
190E	32435	N/A	1.82	35199	33471	35202	EITHER	33934	None
2010C	32435	1.190	1.750	35199	33471	N/A	EITHER	33934	None
270CLC	32441	N/A	2.63	35199	22769	25562	35204	33934	None
290D	32435	N/A	1.85	35199	33471	35202	EITHER	33934	None
330CLC	32441	N/A	2.63	35199	22769	25562	35204	33934	None
330LC	32441	N/A	2.63	35199	22769	25562	35204	33934	None
350B	32435	N/A	1.752	35199	33471	35205	EITHER	33934	None
350C	32435	N/A	1.752	35199	33471	35205	EITHER	33934	None
350D	32435	N/A	1.752	35199	33471	35202	EITHER	33934	None
400G	32435	N/A	1.752	35199	33471	35202	EITHER	33934	None
420C	32435	N/A	1.561	35199	32437	35202	35204	33934	None
450C	33472	1.387	2.128	35199	35205	N/A	25546	33934	None
450C	33472	N/A	2.008	35199	35205	25562	25546	33934	None
450C	33472	N/A	2.128	35199	35205	25562	25546	33934	None
450D	32435	N/A	2.008	35199	35205	25562	25546	33934	None
450D	32435	N/A	2.008	35199	35205	25562	25546	33934	None

WTC Machinery
MPP 100 Tooling Chart

				MASTER PIN RMOVAL AND INSTALLATION					
MAKE	MODEL	COMMENTS	PITCH	PIN LENGTH	PIN DIA	FORCING PIN (A)	ALIGNING BUSHING (2)(B)		PILOT PIN ©
							REMOVAL	INSTALL	
JOHN DEERE	450E	Sealed	6.29	6.36	1.26	25498	Not Req'd	Not Req'd	25502
JOHN DEERE	450G	Sealed	6.29	6.36	1.26	25498	Not Req'd	Not Req'd	25502
JOHN DEERE	450LC		8.5	10	1.873	25551	22751	22749	Not Req'd
JOHN DEERE	455G		6.29	6.36	1.26	25498	Not Req'd	Not Req'd	25502
JOHN DEERE	490D		6.75	7.01	1.318	25499	Not Req'd	Not Req'd	25502
JOHN DEERE	490E		6.73	6.7	1.33	25499	Not Req'd	Not Req'd	25502
JOHN DEERE	550A		6.29	6.36	1.26	25498	Not Req'd	Not Req'd	25502
JOHN DEERE	550G		6.29	6.36	1.26	25498	Not Req'd	Not Req'd	25502
JOHN DEERE	555A		6.29	6.36	1.26	25498	Not Req'd	Not Req'd	25502
JOHN DEERE	555G		6.734	7.22	1.318	25499	Not Req'd	Not Req'd	25502
JOHN DEERE	590D		6.75	7.598	1.378	25499	Not Req'd	22779	25502
JOHN DEERE	605C		6.730	7.165	1.259	25498	Not Req'd	Not Req'd	25502
JOHN DEERE	650G		6.734	7.22	1.318	25499	Not Req'd	Not Req'd	25502
JOHN DEERE	650J		6.730	7.165	1.259	25498	Not Req'd	Not Req'd	25502
JOHN DEERE	690A		6.734	6.97	1.317	25499	Not Req'd	Not Req'd	25502
JOHN DEERE	690B		6.734	6.97	1.317	25499	Not Req'd	Not Req'd	25502

WTC Machinery
MPP 100 Tooling Chart

				BUSHING REMOVAL		BUSHING INSTALL			
MODEL	ALIGNING ADAPTOR (D)	BUSHING ID	BUSHING OD	BUSHING PUSHER (E)	BUSHING ADAPTER (F)	REAR BUSH ASSY PLATE (G)	BUSHING INSTALLER (H)	REAR FORCING PIN (J)	SPECIAL TOOLING
450E	32435	N/A	2.008	35199	35205	25562	25546	33934	None
450G	32435	N/A	2.008	35199	35205	25562	25546	33934	None
450LC	32441	N/A	2.809	35199	22787	25563	35204	33934	None
455G	32435	N/A	2.008	35199	35205	25562	25546	33934	None
490D	22471	N/A	1.984	35199	35205	35202	EITHER	33936	None
490E	22471	N/A	1.99	35199	35205	35202	25546	33934	None
550A	32435	N/A	2.008	35199	35205	25562	25546	33934	None
550G	32435	N/A	2.008	35199	35205	25562	25546	33934	None
555A	32435	N/A		CHECK	32437	35202	35204	33934	None
555G	22471	N/A	2.12	35199	35205	25562	25546	33936	None
590D	33472	N/A	2.116	35199	35205	25562	25546	33936	None
605C	32435	1.275	1.877	35199	33471	N/A	EITHER	33936	None
650G	22471	N/A	2.119	35199	35205	25562	25546	33936	None
650J	32435	1.275	1.877	35199	33471	N/A	EITHER	33936	None
690A	22471	N/A	1.99	35199	35205	35202	25546	33934	None
690B	22471	N/A	1.99	35199	35205	35202	25546	33934	None

WTC Machinery
MPP 100 Tooling Chart

				MASTER PIN RMOVAL AND INSTALLATION					
MAKE	MODEL	COMMENTS	PITCH	PIN LENGTH	PIN DIA	FORCING PIN (A)	ALIGNING BUSHING (2)(B)		PILOT PIN ©
							REMOVAL	INSTALL	
JOHN DEERE	690C		6.734	6.97	1.317	25499	Not Req'd	Not Req'd	25502
JOHN DEERE	690D		6.734	6.97	1.317	25499	Not Req'd	Not Req'd	25502
JOHN DEERE	690E		7.48	8.15	1.437	25500	Not Req'd	22779	Not Req'd
JOHN DEERE	690E-LC		7.48	8.15	1.437	25500	Not Req'd	22779	Not Req'd
JOHN DEERE	693B		6.734	6.97	1.317	25499	Not Req'd	Not Req'd	25502
JOHN DEERE	693D		6.909	8.11	1.44	25500	Not Req'd	22779	Not Req'd
JOHN DEERE	750/B		6.909	8.11	1.44	25500	Not Req'd	22779	Not Req'd
JOHN DEERE	750C		7.48	8.125	1.437	25500	Not Req'd	22779	Not Req'd
JOHN DEERE	755/B		6.909	8.11	1.44	25500	Not Req'd	22779	Not Req'd
JOHN DEERE	755A		8	9.06	1.753	25548	22777	22751	Not Req'd
JOHN DEERE	790D		7.48	8.58	1.496	25500	Not Req'd	22779	Not Req'd
JOHN DEERE	790E		7.48	8.346	1.496	25500	Not Req'd	22779	Not Req'd
JOHN DEERE	792/D		8	9.65	1.75	25548	22777	22751	Not Req'd
JOHN DEERE	850B		7.984	9.06	1.753	25548	22777	22751	Not Req'd
JOHN DEERE	850C		7.984	9.06	1.753	25548	22777	22751	Not Req'd
JOHN DEERE	850D		10.250	12.125	2.245	25501	Not Req'd	Not Req'd	Not Req'd

WTC Machinery
MPP 100 Tooling Chart

MODEL	ALIGNING ADAPTOR (D)	BUSHING ID	BUSHING OD	BUSHING REMOVAL		BUSHING INSTALL		REAR FORCING PIN (J)	SPECIAL TOOLING
				BUSHING PUSHER (E)	BUSHING ADAPTER (F)	REAR BUSH ASSY PLATE (G)	BUSHING INSTALLER (H)		
690C	22471	N/A	1.99	35199	35205	35202	25546	33934	None
690D	22471	N/A	1.99	35199	35205	35202	25546	33934	None
690E	33472	N/A	2.311	35199	35205	25562	25546	33936	None
690E-LC	33472	N/A	2.311	35199	35205	25562	25546	33936	None
693B	22471	N/A	1.99	35199	35205	35205	25546	33934	None
693D	33472	N/A	1.99	35199	35205	35205	25546	33936	None
750/B	33472	N/A	2.314	35199	35205	25562	25546	33936	None
750C	33472	N/A	2.402	35199	22769	25562	25546	33936	None
755/B	33472	N/A	2.314	35199	35205	25562	25546	33936	None
755A	32441	N/A	2.62	35199	22769	25562	25546	33934	None
790D	32437	N/A	2.323	35199	35205	25562	25546	33936	None
790E	32437	N/A	2.322	35199	35205	25562	25546	33936	None
792/D	32441	N/A	2.618	35199	22769	25562	25546	33934	None
850B	32441	N/A	2.621	35199	22769	25562	35204	33934	None
850C	32441	N/A	2.621	35199	22769	25562	35204	33934	None
850D	33474	N/A	3.375	32434	31658	25561	25546	33934	None

WTC Machinery
MPP 100 Tooling Chart

				MASTER PIN RMOVAL AND INSTALLATION					
MAKE	MODEL	COMMENTS	PITCH	PIN LENGTH	PIN DIA	FORCING PIN (A)	ALIGNING BUSHING (2)(B)		PILOT PIN ©
							REMOVAL	INSTALL	
JOHN DEERE	850J		8	10.315	1.75	25548	22777	22751	Not Req'd
JOHN DEERE	890A		8.5	9.882	1.881	25551	22751	22749	Not Req'd
JOHN DEERE	892D		8	9.65	1.75	25548	22777	22751	Not Req'd
JOHN DEERE	892E		8	9.65	1.75	25548	22777	22751	Not Req'd
JOHN DEERE	950J		8.5	10.86	1.87	25551	22751	22749	Not Req'd
JOHN DEERE	992D		8.5	10	1.873	25551	22751	22749	Not Req'd
JOHN DEERE	992E		8.5	10	1.873	25551	22751	22749	Not Req'd
JOHN DEERE	EX120-2		6.73	6.7	1.33	25499	Not Req'd	Not Req'd	25502
Kobelco	K909A		7.48	8.58	1.496	25500	Not Req'd	22779	Not Req'd
KOMATSU	D120-15		9	11.3	1.988	25551	22751	22749	Not Req'd
KOMATSU	D120-18		9	11.312	1.996	25551	22749	Not Req'd	Not Req'd
KOMATSU	D120-8		9	11.312	1.996	25551	22749	Not Req'd	Not Req'd
KOMATSU	D125-18		9	11.312	1.996	25551	22749	Not Req'd	Not Req'd
KOMATSU	D150-1	OLD	9	11.312	1.996	25551	22749	Not Req'd	Not Req'd
KOMATSU	D150-1	NEW	9.000	11.312	1.918	25551	22751	22749	Not Req'd
KOMATSU	D155-1	OLD	9	11.312	1.996	25551	22749	Not Req'd	Not Req'd

WTC Machinery
MPP 100 Tooling Chart

MODEL	ALIGNING ADAPTOR (D)	BUSHING ID	BUSHING OD	BUSHING REMOVAL		BUSHING INSTALL		REAR FORCING PIN (J)	SPECIAL TOOLING
				BUSHING PUSHER (E)	BUSHING ADAPTER (F)	REAR BUSH ASSY PLATE (G)	BUSHING INSTALLER (H)		
850J	32441	N/A	2.756	35199	35206	25563	35204	33934	None
890A	32441	N/A	2.811	32434	22787	25563	35204	33934	None
892D	32441	N/A	2.618	35199	22769	25562	25546	33934	None
892E	32441	N/A	2.618	35199	22769	25562	25546	33934	None
950J	32441	N/A	3.09	35199	22771	25561	25546	33934	None
992D	32441	N/A	2.809	35199	22787	25563	35204	33934	None
992E	32441	N/A	2.809	35199	22787	25563	35204	33934	None
EX120-2	22471	N/A	1.99	35199	35205	35205	25546	33934	None
K909A	32437	N/A	2.171	35199	35205	25562	25546	33936	None
D120-15	32441	N/A	2.854	32434	22787	25563	35204	33934	None
D120-18	32441	N/A	N/A	32434	Not Req'd	N/A	25546	33934	None
D120-8	32441	N/A	N/A	32434	Not Req'd	N/A	25546	33934	None
D125-18	32441	N/A	N/A	32434	Not Req'd	N/A	25546	33934	None
D150-1	32441	N/A	N/A	32434	Not Req'd	N/A	25546	33934	None
D150-1	33471	N/A	N/A	32434	Not Req'd	N/A	25546	33934	None
D155-1	32441	N/A	N/A	32434	Not Req'd	N/A	25546	33934	None

WTC Machinery
MPP 100 Tooling Chart

				MASTER PIN RMOVAL AND INSTALLATION					
MAKE	MODEL	COMMENTS	PITCH	PIN LENGTH	PIN DIA	FORCING PIN (A)	ALIGNING BUSHING (2)(B)		PILOT PIN ©
							REMOVAL	INSTALL	
KOMATSU	D155-1	NEW	9.000	11.312	1.918	25551	22751	22749	Not Req'd
KOMATSU	D155A-1		9	11.3	1.909	25551	22751	22749	Not Req'd
KOMATSU	D155A-5		9	11.48	1.909	25551	22751	22749	Not Req'd
KOMATSU	D155AX-3		9	11.48	1.909	25551	22751	22749	Not Req'd
KOMATSU	D155AX-5		9	11.48	1.909	25551	22751	22749	Not Req'd
KOMATSU	D20	SALT	5.31	5.55	0.945	200281	Not Req'd	Not Req'd	25505
KOMATSU	D20	Sealed	5.31	5.63	0.945	200281	Not Req'd	Not Req'd	25505
KOMATSU	D20-2		5.312	5.500	0.943	200281	Not Req'd	Not Req'd	25505
KOMATSU	D20-3		5.312	5.500	0.943	200281	Not Req'd	Not Req'd	25505
KOMATSU	D21		5.312	5.500	0.943	200281	Not Req'd	Not Req'd	25505
KOMATSU	D250		10.25	12.32	2.165	25501	Not Req'd	Not Req'd	Not Req'd
KOMATSU	D30-12		6.625	6.625	1.1	200281	Not Req'd	Not Req'd	25504
KOMATSU	D30-15		6.625	6.625	1.1	200281	Not Req'd	Not Req'd	25504
KOMATSU	D30-6		6.625	6.625	1.1	200281	Not Req'd	Not Req'd	25504
KOMATSU	D30A		6.06	6.59	1.102	200281	Not Req'd	Not Req'd	25504
KOMATSU	D30S-1		6.06	6.59	1.094	200281	Not Req'd	Not Req'd	25505

WTC Machinery
MPP 100 Tooling Chart

				BUSHING REMOVAL		BUSHING INSTALL			
MODEL	ALIGNING ADAPTOR (D)	BUSHING ID	BUSHING OD	BUSHING PUSHER (E)	BUSHING ADAPTER (F)	REAR BUSH ASSY PLATE (G)	BUSHING INSTALLER (H)	REAR FORCING PIN (J)	SPECIAL TOOLING
D155-1	33471	N/A	N/A	32434	Not Req'd	N/A	25546	33934	None
D155A-1	32441	N/A	3.011	32434	22787	25561	25546	33934	None
D155A-5	32441	N/A	3.03	32434	22787	25561	25546	33934	None
D155AX-3	32441	N/A	3.03	32434	22787	25561	25546	33934	None
D155AX-5	32441	N/A	3.03	32434	22787	25561	25546	33934	None
D20	32435	N/A	1.6	35199	33471	35202	35204	33934	None
D20	32435	N/A	1.614	35199	33471	35202	35204	33934	None
D20-2	32435	N/A	N/A	35199	Not Req'd	N/A	25546	33934	None
D20-3	32435	N/A	N/A	35199	Not Req'd	N/A	25546	33934	None
D21	32435	N/A	N/A	35199	Not Req'd	N/A	25546	33934	None
D250	33474	N/A	3.11	32434	22771	25561	25546	33934	None
D30-12	32435	N/A	N/A	35199	Not Req'd	N/A	25546	33934	None
D30-15	32435	N/A	N/A	35199	Not Req'd	N/A	25546	33934	None
D30-6	32435	N/A	N/A	35199	Not Req'd	N/A	25546	33934	None
D30A	32435	N/A	1.772	35199	33471	35202	EITHER	33934	None
D30S-1	32435	N/A	1.772	35199	33471	35202	EITHER	33934	None

WTC Machinery
MPP 100 Tooling Chart

				MASTER PIN RMOVAL AND INSTALLATION					
MAKE	MODEL	COMMENTS	PITCH	PIN LENGTH	PIN DIA	FORCING PIN (A)	ALIGNING BUSHING (2)(B)		PILOT PIN ©
							REMOVAL	INSTALL	
KOMATSU	D30S-15		6.06	6.59	1.102	200281	Not Req'd	Not Req'd	25504
KOMATSU	D31		6.625	6.625	1.1	200281	Not Req'd	Not Req'd	25504
KOMATSU	D31 (PC100)		6.06	6.69	1.181	25498	Not Req'd	Not Req'd	25504
KOMATSU	D31-15		6.06	6.59	1.102	200281	Not Req'd	Not Req'd	25504
KOMATSU	D31-16		6.06	6.69	1.102	200281	Not Req'd	Not Req'd	25504
KOMATSU	D355		10.25	12.58	2.244	25501	Not Req'd	Not Req'd	Not Req'd
KOMATSU	D355-1	OLD	9.000	11.563	2.245	25501	Not Req'd	Not Req'd	Not Req'd
KOMATSU	D355-1	NEW	10.250	12.563	2.087	25501	22749	Not Req'd	Not Req'd
KOMATSU	D355-3		10.250	12.750	2.087	25501	22749	Not Req'd	Not Req'd
KOMATSU	D355A-1		10.25	12.58	2.244	25501	Not Req'd	Not Req'd	Not Req'd
KOMATSU	D355A-3		10.25	12.74	2.185	25501	Not Req'd	Not Req'd	Not Req'd
KOMATSU	D375A-1		10.25	12.61	2.244	25501	Not Req'd	Not Req'd	Not Req'd
KOMATSU	D375A-2		11.04	12.77	2.362	25553	Not Req'd	Not Req'd	Not Req'd
KOMATSU	D375A-5		11.04	12.77	2.362	25553	Not Req'd	Not Req'd	Not Req'd
KOMATSU	D37P		6.06	6.69	1.102	200281	Not Req'd	Not Req'd	25504
KOMATSU	D40	Recessed	6.89	8.58	1.488	25500	Not Req'd	22779	Not Req'd

WTC Machinery
MPP 100 Tooling Chart

MODEL	ALIGNING ADAPTOR (D)	BUSHING ID	BUSHING OD	BUSHING REMOVAL		BUSHING INSTALL		REAR FORCING PIN (J)	SPECIAL TOOLING
				BUSHING PUSHER (E)	BUSHING ADAPTER (F)	REAR BUSH ASSY PLATE (G)	BUSHING INSTALLER (H)		
D30S-15	32435	N/A	1.772	35199	33471	35202	EITHER	33934	None
D31	32435	N/A	N/A	35199	Not Req'd	N/A	25546	33934	None
D31 (PC100)	32435	N/A	1.82	35199	33471	35202	EITHER	33934	None
D31-15	32435	N/A	1.772	35199	33471	35202	EITHER	33934	None
D31-16	32435	N/A	1.772	35199	33471	35202	EITHER	33934	None
D355	33474	N/A	3.346	32434	31658	25561	25546	33934	None
D355-1	33474	N/A	N/A	32434	Not Req'd	N/A	25546	33934	None
D355-1	32441	N/A	N/A	32434	Not Req'd	N/A	25546	33934	None
D355-3	32441	N/A	N/A	32434	Not Req'd	N/A	25546	33934	None
D355A-1	33474	N/A	3.346	32434	31658	25561	25546	33934	None
D355A-3	33474	N/A	3.346	32434	31658	25561	25546	33934	None
D375A-1	33474	N/A	3.648	32434	Not Req'd	25561	25546	33934	None
D375A-2	Not Req'd	N/A	3.86	32434	Not Req'd	25561	25546	33934	None
D375A-5	Not Req'd	N/A	3.876	32434	Not Req'd	25561	25546	33934	None
D37P	32435	N/A	1.85	35199	33471	35202	EITHER	33934	None
D40	32437	N/A	2.165	35199	35205	25562	25546	33936	None

WTC Machinery
MPP 100 Tooling Chart

				MASTER PIN RMOVAL AND INSTALLATION					
MAKE	MODEL	COMMENTS	PITCH	PIN LENGTH	PIN DIA	FORCING PIN (A)	ALIGNING BUSHING (2)(B)		PILOT PIN ©
							REMOVAL	INSTALL	
KOMATSU	D40	SALT	6.89	7.13	1.377	25499	Not Req'd	22779	25502
KOMATSU	D40	Sealed	6.89	7.17	1.382	25499	Not Req'd	22779	25502
KOMATSU	D40-1		6.875	8.5625	1.494	25500	22779	22779	Not Req'd
KOMATSU	D40P-1		6.906	8.661	1.496	25500	Not Req'd	22779	Not Req'd
KOMATSU	D41	S/N 216338 & U	6.89	7.17	1.382	25499	Not Req'd	22779	25502
KOMATSU	D41	SALT	6.89	7.17	1.382	25499	Not Req'd	22779	25502
KOMATSU	D41	Sealed	6.89	7.17	1.382	25499	Not Req'd	22779	25502
KOMATSU	D41	Unsealed	6.89	7.17	1.382	25499	Not Req'd	22779	25502
KOMATSU	D41-6		6.75	7.224	1.307	25499	Not Req'd	Not Req'd	25502
KOMATSU	D41A.S.P.Q-3		6.906	8.661	1.496	25500	Not Req'd	22779	Not Req'd
KOMATSU	D41PX-12		6.875	7.845	1.432	25500	Not Req'd	22779	Not Req'd
KOMATSU	PC240		7.677	7.48	1.496	25500	Not Req'd	22779	Not Req'd
KOMATSU	D45		6.89	8.58	1.488	25500	Not Req'd	22779	Not Req'd
KOMATSU	D450		8.858	8.66	1.85	25551	22751	22749	Not Req'd
KOMATSU	D45-1		6.875	8.5625	1.494	25500	22779	22779	Not Req'd
KOMATSU	D455		12.5	14.37	2.756	25553	Not Req'd	Not Req'd	Not Req'd

WTC Machinery
MPP 100 Tooling Chart

MODEL	ALIGNING ADAPTOR (D)	BUSHING ID	BUSHING OD	BUSHING REMOVAL		BUSHING INSTALL		REAR FORCING PIN (J)	SPECIAL TOOLING
				BUSHING PUSHER (E)	BUSHING ADAPTER (F)	REAR BUSH ASSY PLATE (G)	BUSHING INSTALLER (H)		
D40	33472	N/A	2.043	35199	35205	25562	25546	33936	None
D40	33472	N/A	2.085	35199	35205	25562	25546	33936	None
D40-1	32437	N/A	N/A	35199	Not Req'd	N/A	25546	33936	None
D40P-1	32437	N/A	2.165	35199	35205	25562	25546	33936	None
D41	33472	N/A	2.085	35199	35205	25562	25546	33936	None
D41	33472	N/A	2.085	35199	35205	25562	25546	33936	None
D41	33472	N/A	2.085	35199	35205	25562	25546	33936	None
D41	33472	N/A	2.179	35199	35205	25562	25546	33936	None
D41-6	32435	N/A	2.283	35199	35205	25562	25546	33936	None
D41A.S.P.Q-3	32437	N/A	2.165	35199	35205	25562	25546	33936	None
D41PX-12	33472	N/A	2.365	35199	22769	25562	25546	33936	None
PC240	32437	N/A	2.165	35199	35205	25562	25546	33936	None
D45	32437	N/A	2.165	35199	35205	25562	25546	33936	None
D450	32441	N/A	2.803	35199	35206	25563	35204	33936	None
D45-1	32437	N/A	N/A	35199	Not Req'd	N/A	25546	33936	None
D455	Not Req'd	N/A	4.25	32434	Not Req'd	25561	25546	33934	None

WTC Machinery
MPP 100 Tooling Chart

				MASTER PIN RMOVAL AND INSTALLATION					
MAKE	MODEL	COMMENTS	PITCH	PIN LENGTH	PIN DIA	FORCING PIN (A)	ALIGNING BUSHING (2)(B)		PILOT PIN ©
							REMOVAL	INSTALL	
KOMATSU	D455A-1		12.5	14.37	2.756	25553	Not Req'd	Not Req'd	Not Req'd
KOMATSU	D45A		6.906	8.661	1.496	25500	Not Req'd	22779	Not Req'd
KOMATSU	D45B		6.906	8.661	1.496	25500	Not Req'd	22779	Not Req'd
KOMATSU	D45P-1		6.89	7.17	1.382	25499	Not Req'd	22779	25502
KOMATSU	D50		6.89	7.13	1.377	25499	Not Req'd	22779	25502
KOMATSU	D50-10		6.875	8.5625	1.494	25500	22779	22779	Not Req'd
KOMATSU	D50-11		6.875	8.5625	1.494	25500	22779	22779	Not Req'd
KOMATSU	D50-11		6.89	8.58	1.488	25500	Not Req'd	22779	Not Req'd
KOMATSU	D50-15		6.875	8.5625	1.494	25500	22779	22779	Not Req'd
KOMATSU	D50-15		6.89	8.58	1.488	25500	Not Req'd	22779	Not Req'd
KOMATSU	D50A		6.906	8.661	1.496	25500	Not Req'd	22779	Not Req'd
KOMATSU	D50B		6.906	8.661	1.496	25500	Not Req'd	22779	Not Req'd
KOMATSU	D50P		6.906	8.661	1.496	25500	Not Req'd	22779	Not Req'd
KOMATSU	D50S		6.906	8.661	1.496	25500	Not Req'd	22779	Not Req'd
KOMATSU	D53	SALT	6.89	7.13	1.377	25499	Not Req'd	22779	25502
KOMATSU	D53	S/N 1334 & UP	6.89	7.17	1.382	25499	Not Req'd	22779	25502

WTC Machinery
MPP 100 Tooling Chart

MODEL	ALIGNING ADAPTOR (D)	BUSHING ID	BUSHING OD	BUSHING REMOVAL		BUSHING INSTALL		REAR FORCING PIN (J)	SPECIAL TOOLING
				BUSHING PUSHER (E)	BUSHING ADAPTER (F)	REAR BUSH ASSY PLATE (G)	BUSHING INSTALLER (H)		
D455A-1	Not Req'd	N/A	4.25	32434	Not Req'd	25561	25546	33934	None
D45A	32437	N/A	2.165	35199	35205	25562	25546	33936	None
D45B	32437	N/A	2.165	35199	35205	25562	25546	33936	None
D45P-1	33472	N/A	2.085	35199	35205	25562	25546	33936	None
D50	33472	N/A	2.043	35199	35205	25562	25546	33936	None
D50-10	32437	N/A	N/A	35199	Not Req'd	N/A	25546	33936	None
D50-11	32437	N/A	N/A	35199	Not Req'd	N/A	25546	33936	None
D50-11	32437	N/A	2.165	35199	35205	25562	25546	33936	None
D50-15	32437	N/A	N/A	35199	Not Req'd	N/A	25546	33936	None
D50-15	32437	N/A	2.165	35199	35205	25562	25546	33936	None
D50A	32437	N/A	2.165	35199	35205	25562	25546	33936	None
D50B	32437	N/A	2.165	35199	35205	25562	25546	33936	None
D50P	32437	N/A	2.165	35199	35205	25562	25546	33936	None
D50S	32437	N/A	2.165	35199	35205	25562	25546	33936	None
D53	33472	N/A	2.043	35199	35205	25562	25546	33936	None
D53	33472	N/A	2.085	35199	35205	25562	25546	33936	None

WTC Machinery
MPP 100 Tooling Chart

				MASTER PIN RMOVAL AND INSTALLATION					
MAKE	MODEL	COMMENTS	PITCH	PIN LENGTH	PIN DIA	FORCING PIN (A)	ALIGNING BUSHING (2)(B)		PILOT PIN ©
							REMOVAL	INSTALL	
KOMATSU	D53-15		6.875	8.5625	1.494	25500	22779	22779	Not Req'd
KOMATSU	D53-16		6.89	7.17	1.382	25499	Not Req'd	22779	25502
KOMATSU	D53A		6.906	8.661	1.496	25500	Not Req'd	22779	Not Req'd
KOMATSU	D53A-15		6.89	7.17	1.382	25499	Not Req'd	22779	25502
KOMATSU	D55-2		7.5	8.562	1.494	25500	22779	22779	Not Req'd
KOMATSU	D55-3		7.5	8.562	1.494	25500	22779	22779	Not Req'd
KOMATSU	D55-S		7.48	8.58	1.488	25500	Not Req'd	22779	Not Req'd
KOMATSU	D57-1		7.48	8.66	1.5	25500	Not Req'd	22777	Not Req'd
KOMATSU	D58		6.89	7.13	1.377	25499	Not Req'd	22779	25502
KOMATSU	D58E		6.906	8.661	1.496	25500	Not Req'd	22779	Not Req'd
KOMATSU	D58P-1		6.906	8.661	1.496	25500	Not Req'd	22779	Not Req'd
KOMATSU	D60		8	9.43	1.75	25548	22777	22751	Not Req'd
KOMATSU	D60-1		6.875	8.5625	1.494	25500	22779	22779	Not Req'd
KOMATSU	D60-3		7.5	8.562	1.494	25500	22779	22779	Not Req'd
KOMATSU	D60-6		8	9.4375	1.756	25548	22777	22751	Not Req'd
KOMATSU	D60A	Recessed	7.48	8.58	1.488	25500	Not Req'd	22779	Not Req'd

WTC Machinery
MPP 100 Tooling Chart

MODEL	ALIGNING ADAPTOR (D)	BUSHING ID	BUSHING OD	BUSHING REMOVAL		BUSHING INSTALL		REAR FORCING PIN (J)	SPECIAL TOOLING
				BUSHING PUSHER (E)	BUSHING ADAPTER (F)	REAR BUSH ASSY PLATE (G)	BUSHING INSTALLER (H)		
D53-15	32437	N/A	N/A	35199	Not Req'd	N/A	25546	33936	None
D53-16	33472	N/A	2.085	35199	35205	25562	25546	33936	None
D53A	32437	N/A	2.165	35199	35205	25562	25546	33936	None
D53A-15	33472	N/A	2.085	35199	35205	25562	25546	33936	None
D55-2	32437	N/A	N/A	35199	Not Req'd	N/A	25546	33936	None
D55-3	32437	N/A	N/A	35199	Not Req'd	N/A	25546	33936	None
D55-S	32437	N/A	2.165	35199	35205	25562	25546	33936	None
D57-1	32437	N/A	2.165	35199	35205	25562	25546	33936	None
D58	33472	N/A	2.043	35199	35205	25562	25546	33936	None
D58E	32437	N/A	2.165	35199	35205	25562	25546	33936	None
D58P-1	32437	N/A	2.165	35199	35205	25562	25546	33936	None
D60	32441	N/A	2.618	35199	22769	25562	25546	33934	None
D60-1	32437	N/A	N/A	35199	Not Req'd	N/A	25546	33936	None
D60-3	32437	N/A	N/A	35199	Not Req'd	N/A	25546	33936	None
D60-6	33471	N/A	N/A	35199	Not Req'd	N/A	25546	33934	None
D60A	32437	N/A		CHECK	32437	35202	35204	33936	None

WTC Machinery
MPP 100 Tooling Chart

				MASTER PIN RMOVAL AND INSTALLATION					
MAKE	MODEL	COMMENTS	PITCH	PIN LENGTH	PIN DIA	FORCING PIN (A)	ALIGNING BUSHING (2)(B)		PILOT PIN ©
							REMOVAL	INSTALL	
KOMATSU	D60A	Sealed	7.984	9.449	1.756	25548	22777	22751	Not Req'd
KOMATSU	D61E		7.48	8.897	1.496	25500	Not Req'd	22779	Not Req'd
KOMATSU	D61EX		7.48	8.897	1.496	25500	Not Req'd	22779	Not Req'd
KOMATSU	D61P		7.48	8.897	1.496	25500	Not Req'd	22779	Not Req'd
KOMATSU	D61PX		7.48	8.897	1.496	25500	Not Req'd	22779	Not Req'd
KOMATSU	D63E		6.89	7.13	1.377	25499	Not Req'd	22779	25502
KOMATSU	D65-6		8	9.4375	1.756	25548	22777	22751	Not Req'd
KOMATSU	D65A	S/N 6842 & DN	7.984	9.449	1.756	25548	22777	22751	Not Req'd
KOMATSU	D65E		8	9.43	1.75	25548	22777	22751	Not Req'd
KOMATSU	D65EX-12		8	9.433	1.75	25548	22777	22751	Not Req'd
KOMATSU	D65P-6		8	9.43	1.75	25548	22777	22751	Not Req'd
KOMATSU	D65PX-12		8	9.433	1.75	25548	22777	22751	Not Req'd
KOMATSU	D66	SALT	8	9.53	1.75	25548	22777	22751	Not Req'd
KOMATSU	D66	Sealed	8	9.43	1.75	25548	22777	22751	Not Req'd
KOMATSU	D68	SALT	8	9.53	1.75	25548	22777	22751	Not Req'd
KOMATSU	D68	Sealed	8	9.43	1.75	25548	22777	22751	Not Req'd

WTC Machinery
MPP 100 Tooling Chart

MODEL	ALIGNING ADAPTOR (D)	BUSHING ID	BUSHING OD	BUSHING REMOVAL		BUSHING INSTALL		REAR FORCING PIN (J)	SPECIAL TOOLING
				BUSHING PUSHER (E)	BUSHING ADAPTER (F)	REAR BUSH ASSY PLATE (G)	BUSHING INSTALLER (H)		
D60A	32441	N/A	2.63	35199	22769	25562	35204	33934	None
D61E	32437	N/A	2.56	35199	22769	25562	25546	33936	None
D61EX	32437	N/A	2.56	35199	22769	25562	25546	33936	None
D61P	32437	N/A	2.56	35199	22769	25562	25546	33936	None
D61PX	32437	N/A	2.56	35199	22769	25562	25546	33936	None
D63E	33472	N/A	2.043	35199	35205	25562	25546	33936	None
D65-6	33471	N/A	N/A	35199	Not Req'd	N/A	25546	33934	None
D65A	32441	N/A	2.618	35199	22769	25562	25546	33934	None
D65E	32441	N/A	2.618	35199	22769	25562	25546	33934	None
D65EX-12	32441	N/A	2.618	35199	22769	25562	25546	33934	None
D65P-6	32441	N/A	2.618	35199	22769	25562	25546	33934	None
D65PX-12	32441	N/A	2.618	35199	22769	25562	25546	33934	None
D66	32441	N/A	2.751	35199	35206	25563	35204	33934	None
D66	32441	N/A	2.618	35199	22769	25562	25546	33934	None
D68	32441	N/A	2.75	35199	35206	25563	35204	33934	None
D68	32441	N/A	2.618	35199	22769	25562	25546	33934	None

WTC Machinery
MPP 100 Tooling Chart

				MASTER PIN RMOVAL AND INSTALLATION					
MAKE	MODEL	COMMENTS	PITCH	PIN LENGTH	PIN DIA	FORCING PIN (A)	ALIGNING BUSHING (2)(B)		PILOT PIN ©
							REMOVAL	INSTALL	
KOMATSU	D75		8.5	10	1.85	25551	22751	22749	Not Req'd
KOMATSU	D75-2		8.500	9.875	1.851	25551	22751	22749	Not Req'd
KOMATSU	D75-3		8.500	9.875	1.851	25551	22751	22749	Not Req'd
KOMATSU	D75-S		8.5	9.84	1.85	25551	22751	22749	Not Req'd
KOMATSU	D80		8.5	10	1.85	25551	22751	22749	Not Req'd
KOMATSU	D80-12		8.5	9.875	1.851	25551	22751	22749	Not Req'd
KOMATSU	D80-7		8.000	9.875	1.754	25548	22777	22751	Not Req'd
KOMATSU	D80-8		8.000	9.875	1.754	25548	22777	22751	Not Req'd
KOMATSU	D85-12		8.5	9.875	1.851	25551	22751	22749	Not Req'd
KOMATSU	D85-18		8.5	10	1.85	25551	22751	22749	Not Req'd
KOMATSU	D85-7		8.000	9.875	1.754	25548	22777	22751	Not Req'd
KOMATSU	D85-8		8.000	9.875	1.754	25548	22777	22751	Not Req'd
KOMATSU	D85A		8.5	10	1.85	25551	22751	22749	Not Req'd
KOMATSU	D85A-12		8.5	9.84	1.85	25551	22751	22749	Not Req'd
KOMATSU	D85E		8.5	10	1.85	25551	22751	22749	Not Req'd
KOMATSU	D85E-12		8.5	9.84	1.772	25551	22751	22751	Not Req'd

WTC Machinery
MPP 100 Tooling Chart

MODEL	ALIGNING ADAPTOR (D)	BUSHING ID	BUSHING OD	BUSHING REMOVAL		BUSHING INSTALL		REAR FORCING PIN (J)	SPECIAL TOOLING
				BUSHING PUSHER (E)	BUSHING ADAPTER (F)	REAR BUSH ASSY PLATE (G)	BUSHING INSTALLER (H)		
D75	32441	N/A	2.925	35199	22787	25563	35204	33934	None
D75-2	33471	N/A	N/A	35199	Not Req'd	N/A	25546	33934	None
D75-3	33471	N/A	N/A	35199	Not Req'd	N/A	25546	33934	None
D75-S	32441	N/A	2.803	35199	35206	25563	35204	33934	None
D80	32441	N/A	2.925	35199	22787	25563	35204	33934	None
D80-12	33471	N/A	N/A	35199	Not Req'd	N/A	25546	33934	None
D80-7	33471	N/A	N/A	35199	Not Req'd	N/A	25546	33934	None
D80-8	33471	N/A	N/A	35199	Not Req'd	N/A	25546	33934	None
D85-12	33471	N/A	N/A	35199	Not Req'd	N/A	25546	33934	None
D85-18	32441	N/A	2.925	35199	22787	25563	35204	33934	None
D85-7	33471	N/A	N/A	35199	Not Req'd	N/A	25546	33934	None
D85-8	33471	N/A	N/A	35199	Not Req'd	N/A	25546	33934	None
D85A	32441	N/A	2.295	35199	35205	25562	25546	33934	None
D85A-12	32441	N/A	2.803	35199	35206	25563	35204	33934	None
D85E	32441	N/A	2.925	35199	22787	25563	35204	33934	None
D85E-12	32441	N/A	2.795	35199	35206	25563	35204	33934	None

WTC Machinery
MPP 100 Tooling Chart

				MASTER PIN RMOVAL AND INSTALLATION					
MAKE	MODEL	COMMENTS	PITCH	PIN LENGTH	PIN DIA	FORCING PIN (A)	ALIGNING BUSHING (2)(B)		PILOT PIN ©
							REMOVAL	INSTALL	
KOMATSU	D85P-18		8.5	10	1.85	25551	22751	22749	Not Req'd
KOMATSU	D95		8.5	10	1.85	25551	22751	22749	Not Req'd
KOMATSU	D95-1		8.500	10.000	1.772	25551	22777	22751	Not Req'd
KOMATSU	D95-S		8.5	10	1.772	25551	22751	22751	Not Req'd
KOMATSU	EX1800		12.5	14.45	2.756	25553	Not Req'd	Not Req'd	Not Req'd
KOMATSU	PC100		6.06	6.811	1.181	25498	Not Req'd	Not Req'd	25504
KOMATSU	PC100		6.89	6.81	1.18	25498	Not Req'd	Not Req'd	25504
KOMATSU	PC1000		10.25	12.61	2.244	25501	Not Req'd	Not Req'd	Not Req'd
KOMATSU	PC100-1		6.062	6.535	1.181	25498	Not Req'd	Not Req'd	25504
KOMATSU	PC100-2		6.062	6.535	1.181	25498	Not Req'd	Not Req'd	25504
KOMATSU	PC100-3		6.062	6.535	1.181	25498	Not Req'd	Not Req'd	25504
KOMATSU	PC100-6		6.89	6.81	1.18	25498	Not Req'd	Not Req'd	25504
KOMATSU	PC120		6.06	6.811	1.181	25498	Not Req'd	Not Req'd	25504
KOMATSU	PC120		6.89	6.81	1.18	25498	Not Req'd	Not Req'd	25504
KOMATSU	PC120-1		6.062	6.535	1.181	25498	Not Req'd	Not Req'd	25504
KOMATSU	PC120-2		6.062	6.535	1.181	25498	Not Req'd	Not Req'd	25504

WTC Machinery
MPP 100 Tooling Chart

MODEL	ALIGNING ADAPTOR (D)	BUSHING ID	BUSHING OD	BUSHING REMOVAL		BUSHING INSTALL		REAR FORCING PIN (J)	SPECIAL TOOLING
				BUSHING PUSHER (E)	BUSHING ADAPTER (F)	REAR BUSH ASSY PLATE (G)	BUSHING INSTALLER (H)		
D85P-18	32441	N/A	2.925	35199	22787	25563	35204	33934	None
D95	32441	N/A	2.925	35199	22787	25563	35204	33934	None
D95-1	33471	N/A	N/A	35199	Not Req'd	N/A	25546	33934	None
D95-S	32441	N/A	2.8	35199	35206	25563	35204	33934	None
EX1800	Not Req'd	N/A	4.567	32434	Not Req'd	25561	25546	33934	None
PC100	32435	N/A	1.811	35199	33471	35205	EITHER	33934	None
PC100	32435	N/A	1.81	35199	33471	35202	EITHER	33934	None
PC1000	33474	N/A	3.62	32434	31658	25561	25546	33934	None
PC100-1	32435	N/A	1.819	35199	33471	35202	EITHER	33934	None
PC100-2	32435	N/A	1.819	35199	33471	35202	EITHER	33934	None
PC100-3	32435	N/A	1.819	35199	33471	35202	EITHER	33934	None
PC100-6	32435	N/A	1.82	35199	33471	35202	EITHER	33934	None
PC120	32435	N/A	1.82	35199	33471	35202	EITHER	33934	None
PC120	32435	N/A	1.81	35199	33471	35202	EITHER	33934	None
PC120-1	32435	N/A	1.819	35199	33471	35202	EITHER	33934	None
PC120-2	32435	N/A	1.819	35199	33471	35202	EITHER	33934	None

WTC Machinery
MPP 100 Tooling Chart

				MASTER PIN RMOVAL AND INSTALLATION					
MAKE	MODEL	COMMENTS	PITCH	PIN LENGTH	PIN DIA	FORCING PIN (A)	ALIGNING BUSHING (2)(B)		PILOT PIN ©
							REMOVAL	INSTALL	
KOMATSU	PC120-3		6.062	6.535	1.181	25498	Not Req'd	Not Req'd	25504
KOMATSU	PC120-6		6.9	6.811	1.181	25498	Not Req'd	Not Req'd	25504
KOMATSU	PC120LC-6		6.89	6.81	1.18	25498	Not Req'd	Not Req'd	25504
KOMATSU	PC130-6		6.89	6.81	1.18	25498	Not Req'd	Not Req'd	25504
KOMATSU	PC138		6.89	6.81	1.18	25498	Not Req'd	Not Req'd	25504
KOMATSU	PC150		6.89	8.66	1.499	25500	Not Req'd	22779	Not Req'd
KOMATSU	PC200		7.48	8.66	1.5	25500	Not Req'd	22777	Not Req'd
KOMATSU	PC220		7.48	8.66	1.5	25500	Not Req'd	22777	Not Req'd
KOMATSU	PC250LC-6		8.5	9.52	1.75	25548	22777	22751	Not Req'd
KOMATSU	PC270LC-6		8.5	9.52	1.75	25548	22777	22751	Not Req'd
KOMATSU	PC270LC-7		8.5	9.52	1.75	25548	22777	22751	Not Req'd
KOMATSU	PC275A-2		10.25	12.61	2.244	25501	Not Req'd	Not Req'd	Not Req'd
KOMATSU	PC300	EXC	8	9.53	1.75	25548	22777	22751	Not Req'd
KOMATSU	PC300HD-6		9	9.92	1.85	25551	22751	22749	Not Req'd
KOMATSU	PC300LC-6		8.5	9.52	1.75	25548	22777	22751	Not Req'd
KOMATSU	PC300LC-7		8.5	9.52	1.75	25548	22777	22751	Not Req'd

WTC Machinery
MPP 100 Tooling Chart

MODEL	ALIGNING ADAPTOR (D)	BUSHING ID	BUSHING OD	BUSHING REMOVAL		BUSHING INSTALL		REAR FORCING PIN (J)	SPECIAL TOOLING
				BUSHING PUSHER (E)	BUSHING ADAPTER (F)	REAR BUSH ASSY PLATE (G)	BUSHING INSTALLER (H)		
PC120-3	32435	N/A	1.819	35199	33471	35202	EITHER	33934	None
PC120-6	32435	N/A	1.81	35199	33471	35202	EITHER	33934	None
PC120LC-6	32435	N/A	1.82	35199	33471	35202	EITHER	33934	None
PC130-6	32435	N/A	1.82	35199	33471	35202	EITHER	33934	None
PC138	32435	N/A	1.82	35199	33471	35202	EITHER	33934	None
PC150	32437	N/A	2.179	35199	35205	25562	25546	33936	None
PC200	32437	N/A	2.165	35199	35205	25562	25546	33936	None
PC220	32437	N/A	2.165	35199	35205	25562	25546	33936	None
PC250LC-6	32441	N/A	2.62	35199	22769	25562	25546	33934	None
PC270LC-6	32441	N/A	2.62	35199	22769	25562	25546	33934	None
PC270LC-7	32441	N/A	2.62	35199	22769	25562	25546	33934	None
PC275A-2	33474	N/A		CHECK	32437	35202	35204	33934	None
PC300	32441	N/A	2.618	35199	22769	25562	25546	33934	None
PC300HD-6	32441	N/A	2.8	35199	35206	25563	35204	33934	None
PC300LC-6	32441	N/A	2.62	35199	22769	25562	25546	33934	None
PC300LC-7	32441	N/A	2.62	35199	22769	25562	25546	33934	None

WTC Machinery
MPP 100 Tooling Chart

				MASTER PIN RMOVAL AND INSTALLATION					
MAKE	MODEL	COMMENTS	PITCH	PIN LENGTH	PIN DIA	FORCING PIN (A)	ALIGNING BUSHING (2)(B)		PILOT PIN ©
							REMOVAL	INSTALL	
KOMATSU	PC400		8.5	10	1.85	25551	22751	22749	Not Req'd
KOMATSU	PC400LC-5		8.5	9.921	1.856	25551	22751	22749	Not Req'd
KOMATSU	PC-400 EX		8.504	10	1.85	25551	22751	22749	Not Req'd
KOMATSU	PC60 EXC		5.31	5.55	0.945	200281	Not Req'd	Not Req'd	25505
KOMATSU	PC600		8.5	10	1.85	25551	22751	22749	Not Req'd
KOMATSU	PC600-6		9	11.41	1.92	25551	22751	22749	Not Req'd
KOMATSU	PC600-7		9	11.41	1.92	25551	22751	22749	Not Req'd
KOMATSU	PC600LC-6		9	11.41	1.92	25551	22751	22749	Not Req'd
KOMATSU	PC600LC-7		9	11.41	1.92	25551	22751	22749	Not Req'd
KOMATSU	PC650-5		10.25	12.61	2.185	25501	Not Req'd	Not Req'd	Not Req'd
KOMATSU	PC700		10.25	12.61	2.185	25501	Not Req'd	Not Req'd	Not Req'd
KOMATSU	PC710		10.25	12.61	2.185	25501	Not Req'd	Not Req'd	Not Req'd
KOMATSU	PC750 SE-6		10.25	12.61	2.185	25501	Not Req'd	Not Req'd	Not Req'd
KOMATSU	PC80		6.06	6.811	1.181	25498	Not Req'd	Not Req'd	25504
KOMATSU	PC800		10.25	12.61	2.185	25501	Not Req'd	Not Req'd	Not Req'd
KOMATSU	PC80-1		6.062	6.535	1.181	25498	Not Req'd	Not Req'd	25504

WTC Machinery
MPP 100 Tooling Chart

MODEL	ALIGNING ADAPTOR (D)	BUSHING ID	BUSHING OD	BUSHING REMOVAL		BUSHING INSTALL		REAR FORCING PIN (J)	SPECIAL TOOLING
				BUSHING PUSHER (E)	BUSHING ADAPTER (F)	REAR BUSH ASSY PLATE (G)	BUSHING INSTALLER (H)		
PC400	32441	N/A	2.925	35199	22787	25563	35204	33934	None
PC400LC-5	32441		2.811	35199	22787	25563	35204	33934	
PC-400 EX	32441	N/A	2.925	35199	22787	25563	35204	33934	None
PC60 EXC	32435	N/A	1.6	35199	33471	35205	35204	33934	None
PC600	32441	N/A	2.79	35199	35206	25563	35204	33934	None
PC600-6	32441	N/A	2.87	32434	22787	25563	35204	33934	None
PC600-7	32441	N/A	2.87	32434	22787	25563	35204	33934	None
PC600LC-6	32441	N/A	2.87	32434	22787	25563	35204	33934	None
PC600LC-7	32441	N/A	2.87	32434	22787	25563	35204	33934	None
PC650-5	33474	N/A	3.445	32434	31658	25561	25546	33934	None
PC700	33474	N/A	3.445	32434	31658	25561	25546	33934	None
PC710	33474	N/A	3.445	32434	31658	25561	25546	33934	None
PC750 SE-6	33474	N/A	3.445	32434	31658	25561	25546	33934	None
PC80	32435	N/A	1.811	35199	33471	35202	EITHER	33934	None
PC800	33474	N/A	3.445	32434	31658	25561	25546	33934	None
PC80-1	32435	N/A	1.819	35199	33471	35202	EITHER	33934	None

WTC Machinery
MPP 100 Tooling Chart

				MASTER PIN RMOVAL AND INSTALLATION					
MAKE	MODEL	COMMENTS	PITCH	PIN LENGTH	PIN DIA	FORCING PIN (A)	ALIGNING BUSHING (2)(B)		PILOT PIN ©
							REMOVAL	INSTALL	
KOMATSU	PC80-3		6.062	6.535	1.181	25498	Not Req'd	Not Req'd	25504
KOMATSU	PC80LC-3		6.062	6.535	1.181	25498	Not Req'd	Not Req'd	25504
KUBOTO	KH170L EXC		5.31	5.51	0.994	200281	Not Req'd	Not Req'd	25505
LIEBHERR	944		6.735	7	1.314	25499	Not Req'd	Not Req'd	25502
LIEBHERR	PR711		6.735	7.22	1.315	25499	Not Req'd	Not Req'd	25502
LIEBHERR	PR721		6.735	8.12	1.442	25500	Not Req'd	22779	Not Req'd
LIEBHERR	PR731		7.985	9.06	1.752	25548	22777	22751	Not Req'd
LIEBHERR	R912		6.735	7	1.314	25499	Not Req'd	Not Req'd	25502
LIEBHERR	R922		6.735	7	1.314	25499	Not Req'd	Not Req'd	25502
LIEBHERR	R932		6.735	8.13	1.442	25500	Not Req'd	22779	Not Req'd
LINKBELT	LS2800		6.735	8.13	1.442	25500	Not Req'd	22779	Not Req'd
LINKBELT	LS4800		8.5	9.88	1.878	25551	22751	22749	Not Req'd
LINKBELT	LS5400		8.5	9.88	1.878	25551	22751	22749	Not Req'd
LINKBELT	LS5800		8.5	9.88	1.878	25551	22751	22749	Not Req'd
LINKBELT	LS6400		9	11.44	2.003	25551	22751	Not Req'd	Not Req'd
LINKBELT	LS7400		9	11.44	2.003	25551	22751	Not Req'd	Not Req'd

WTC Machinery
MPP 100 Tooling Chart

			BUSHING REMOVAL		BUSHING INSTALL				
MODEL	ALIGNING ADAPTOR (D)	BUSHING ID	BUSHING OD	BUSHING PUSHER (E)	BUSHING ADAPTER (F)	REAR BUSH ASSY PLATE (G)	BUSHING INSTALLER (H)	REAR FORCING PIN (J)	SPECIAL TOOLING
PC80-3	32435	N/A	1.819	35199	33471	35202	EITHER	33934	None
PC80LC-3	32435	N/A	1.819	35199	33471	35202	EITHER	33934	None
KH170L EXC	32435	N/A	0.662	CHECK	32437	35202	35204	33934	None
944	22471	N/A		CHECK	32437	35202	35204	33936	None
PR711	22471	N/A	2.205	35199	35205	25562	25546	33936	None
PR721	33472	N/A	2.312	35199	35205	25562	25546	33936	None
PR731	32441	N/A	2.621	35199	22769	25562	35204	33934	None
R912	22471	N/A	1.993	35199	35205	35202	25546	33936	None
R922	22471	N/A	1.993	35199	35205	35202	25546	33936	None
R932	33472	N/A	2.188	35199	35205	25562	25546	33936	None
LS2800	33472	N/A	2.188	35199	35205	25562	25546	33936	None
LS4800	32441	N/A	2.812	32434	22787	25563	35204	33934	None
LS5400	32441	N/A	2.812	32434	22787	25563	35204	33934	None
LS5800	32441	N/A	2.812	32434	22787	25563	35204	33934	None
LS6400	32441	N/A	2.996	32434	22787	25563	35204	33934	None
LS7400	32441	N/A	2.996	32434	22787	25563	35204	33934	None

WTC Machinery
MPP 100 Tooling Chart

				MASTER PIN RMOVAL AND INSTALLATION					
MAKE	MODEL	COMMENTS	PITCH	PIN LENGTH	PIN DIA	FORCING PIN (A)	ALIGNING BUSHING (2)(B)		PILOT PIN ©
							REMOVAL	INSTALL	
LINKBELT	LS7800		6.735	8.13	1.442	25500	Not Req'd	22779	Not Req'd
LINKBELT	LS9800		7.985	9.88	1.752	25548	22777	22751	Not Req'd
MASSEY FERGUSON	MF200B		5.512	5.75	1.063	200281	Not Req'd	Not Req'd	25505
MASSEY FERGUSON	MF2244		5.512	5.42	0.984	200281	Not Req'd	Not Req'd	25505
MASSEY FERGUSON	MF300	Recessed	6.299	6.61	1.299	25499	Not Req'd	Not Req'd	25502
MASSEY FERGUSON	MF300	Sealed	6.299	6.61	1.299	25499	Not Req'd	Not Req'd	25502
MASSEY FERGUSON	MF400C		6.69	7.01	1.38	25499	Not Req'd	22779	25502
MASSEY FERGUSON	MF450		6.299	6.61	1.299	25499	Not Req'd	Not Req'd	25502
MASSEY FERGUSON	MF500		6.69	7.17	1.378	25499	Not Req'd	22779	25502
MASSEY FERGUSON	MF500B		6.75	8.11	1.441	25500	Not Req'd	22779	Not Req'd
MASSEY FERGUSON	MF600C		7.98	8.66	1.752	25548	22777	22751	Not Req'd
MASSEY FERGUSON	MFD400C		6.69	7.01	1.38	25499	Not Req'd	22779	25502
MASSEY FERGUSON	MFD700C		8.5	9.88	1.88	25551	22751	22749	Not Req'd
O&K	RH40C		10.25	12.52	2.28	25553	Not Req'd	Not Req'd	Not Req'd
TEREX	8220		8.000	9.188	1.749	25548	22777	22751	Not Req'd
TEREX	8230		8.000	11.500	1.745	25548	22777	22751	Not Req'd

WTC Machinery
MPP 100 Tooling Chart

				BUSHING REMOVAL		BUSHING INSTALL			
MODEL	ALIGNING ADAPTOR (D)	BUSHING ID	BUSHING OD	BUSHING PUSHER (E)	BUSHING ADAPTER (F)	REAR BUSH ASSY PLATE (G)	BUSHING INSTALLER (H)	REAR FORCING PIN (J)	SPECIAL TOOLING
LS7800	33472	N/A	2.118	35199	35205	25562	25546	33936	None
LS9800	32441	N/A	2.621	35199	22769	25562	35204	33934	None
MF200B	32435	N/A	1.654	35199	33471	35202	35204	33934	None
MF2244	32435	N/A	1.468	35199	32437	35202	35204	33934	None
MF300	32435	N/A	1.968	35199	35205	35202	EITHER	33934	None
MF300	32435	N/A	1.968	35199	35205	35202	EITHER	33934	None
MF400C	33472	N/A	2.048	35199	35205	25562	25546	33936	None
MF450	32435	N/A	1.968	35199	35205	35205	EITHER	33934	None
MF500	33472	N/A	2.048	35199	35205	25562	25546	33936	None
MF500B	33472	N/A	2.122	35199	35205	25562	25546	33936	None
MF600C	32441	N/A	2.618	35199	22769	25562	25546	33936	None
MFD400C	33472	N/A	2.048	35199	35205	25562	25546	33936	None
MFD700C	32441	N/A	2.811	32434	22787	25563	35204	33934	None
RH40C	33474	N/A	3.62	32434	N/A	25561	25546	33934	None
8220	33471	1.769	2.624	35199	22769	N/A	35204	33934	None
8230	33471	1.768	2.624	32434	22771	25561	25546	33934	None

WTC Machinery
MPP 100 Tooling Chart

				MASTER PIN RMOVAL AND INSTALLATION					
MAKE	MODEL	COMMENTS	PITCH	PIN LENGTH	PIN DIA	FORCING PIN (A)	ALIGNING BUSHING (2)(B)		PILOT PIN ©
							REMOVAL	INSTALL	
TEREX	8240	OLD	8.000	11.500	1.745	25548	22777	22751	Not Req'd
TEREX	8240	NEW	9.000	12.563	1.994	25551	22749	Not Req'd	Not Req'd
TEREX	8280		9.000	12.563	1.994	25551	22749	Not Req'd	Not Req'd
TEREX	82-20AA		8	9.19	1.75	25548	22777	22751	Not Req'd
TEREX	82-30		8	9.19	1.75	25548	22777	22751	Not Req'd
TEREX	82-30FA		8	11.52	1.75	25548	22777	22751	Not Req'd
TEREX	82-40AA		8	11.52	1.75	25548	22777	22751	Not Req'd
TEREX	8240CA		9.000	12.500	1.994	25551	22749	Not Req'd	Not Req'd
TEREX	8240DA		9.000	12.500	1.994	25551	22749	Not Req'd	Not Req'd
TEREX	82-50		10.312	12.38	2.38	25553	Not Req'd	Not Req'd	Not Req'd
TEREX	82-80DA		9	12.38	2	25551	22751	Not Req'd	Not Req'd
TEREX	C-260		8.000	11.500	1.745	25548	22777	22751	Not Req'd
TEREX	C-6		8.000	11.500	1.745	25548	22777	22751	Not Req'd
TEREX	TC-12		9.000	12.563	1.994	25551	22749	Not Req'd	Not Req'd
VOLVO	EC150LC		7.5	8.188	1.496	25500	Not Req'd	22779	Not Req'd

WTC Machinery
MPP 100 Tooling Chart

MODEL	ALIGNING ADAPTOR (D)	BUSHING ID	BUSHING OD	BUSHING REMOVAL		BUSHING INSTALL		REAR FORCING PIN (J)	SPECIAL TOOLING
				BUSHING PUSHER (E)	BUSHING ADAPTER (F)	REAR BUSH ASSY PLATE (G)	BUSHING INSTALLER (H)		
8240	33471	1.768	2.624	32434	22771	25561	25546	33934	None
8240	32441	2.019	2.992	32434	22789	25561	25546	33934	None
8280	32441	2.019	2.992	32434	22789	25561	25546	33934	None
82-20AA	32441	N/A	2.88	35199	22787	25563	35204	33934	None
82-30	32441	N/A	2.88	35199	22787	25563	35204	33934	None
82-30FA	32441	N/A	2.88	35199	22787	25563	35204	33934	None
82-40AA	32441	N/A	2.88	35199	22787	25563	35204	33934	None
8240CA	32441	2.019	2.992	32434	22787	N/A	35204	33934	None
8240DA	32441	2.019	2.992	32434	22787	N/A	35204	33934	None
82-50	Not Req'd	N/A	3.5	32434	31658	25561	25546	33934	None
82-80DA	32441	N/A	3.19	32434	22771	25561	25546	33934	None
C-260	33471	1.768	2.624	32434	22771	25561	25546	33934	None
C-6	33471	1.768	2.624	32434	22771	25561	25546	33934	None
TC-12	32441	2.019	2.992	32434	22789	25561	25546	33934	None
EC150LC	32437	N/A	2.323	35199	35205	25562	25546	33936	None