



WTC MACHINERY Engineered to perform. Built to last.

WTC Machinery is a global leader in designing and building machinery and tooling for heavy equipment repair facilities.

WTC HTW Heavy Track Winder

Overview

A simple, safe, compact means to wind up the track chain. Whether used with a track press conveyor system, or located separately, the HTW is the quick, convenient way to finish up track chain assemblies.



Specifications:

Maximum Chain Weight:	22,000 lbs (1000 kg)
Maximum Pad Width:	120" (3,1m)
Machine Weight:	5,760 (2620 kg)
Dimensions:	(W x L x H)
Unloaded:	65" x 100" x 99" (1,65m x 2.54m x 2.51m)

SECTION 2 - B3020 Heavy Track Winder Specifications

MACHINE DIMENSIONS

Weight – 6500 lbs (2950 kg)	Height without track – 100" (2,54 m)
Width – 60" (1,53 m)	Length without track – 110" (2,80 m)
Operating Temperature Range 40° to 110° F (4° to 43° C)	

MAXIMUM TRACK CHAIN LOAD

Maximum Weight.....	22,000 lbs (10000 kg)
Maximum Coiled Diameter.....	120 inches (3,1 m)
Maximum Width Including Shoes.....	48 inches (1,22 m)

WINDING SPEED

50 Hz Supply	1.9 RPM
60 Hz Supply	2.3 RPM

ELECTRICAL

5 Hp (5.42 kW) 3 Phase Electric

Standard Voltages:

<u>50 Hz (1500 rpm)</u>	<u>60 Hz (1800 rpm)</u>
440 V / 7.1 A	460 V / 6.8 A
380 V / 8.3 A	230 V / 13.6 A
220 V / 14.2 A	208 V / 15.0 A
Other voltages available	

SPECIFICATIONS SUBJECT TO CHANGE WITHOUT NOTICE

Control and Part Identification

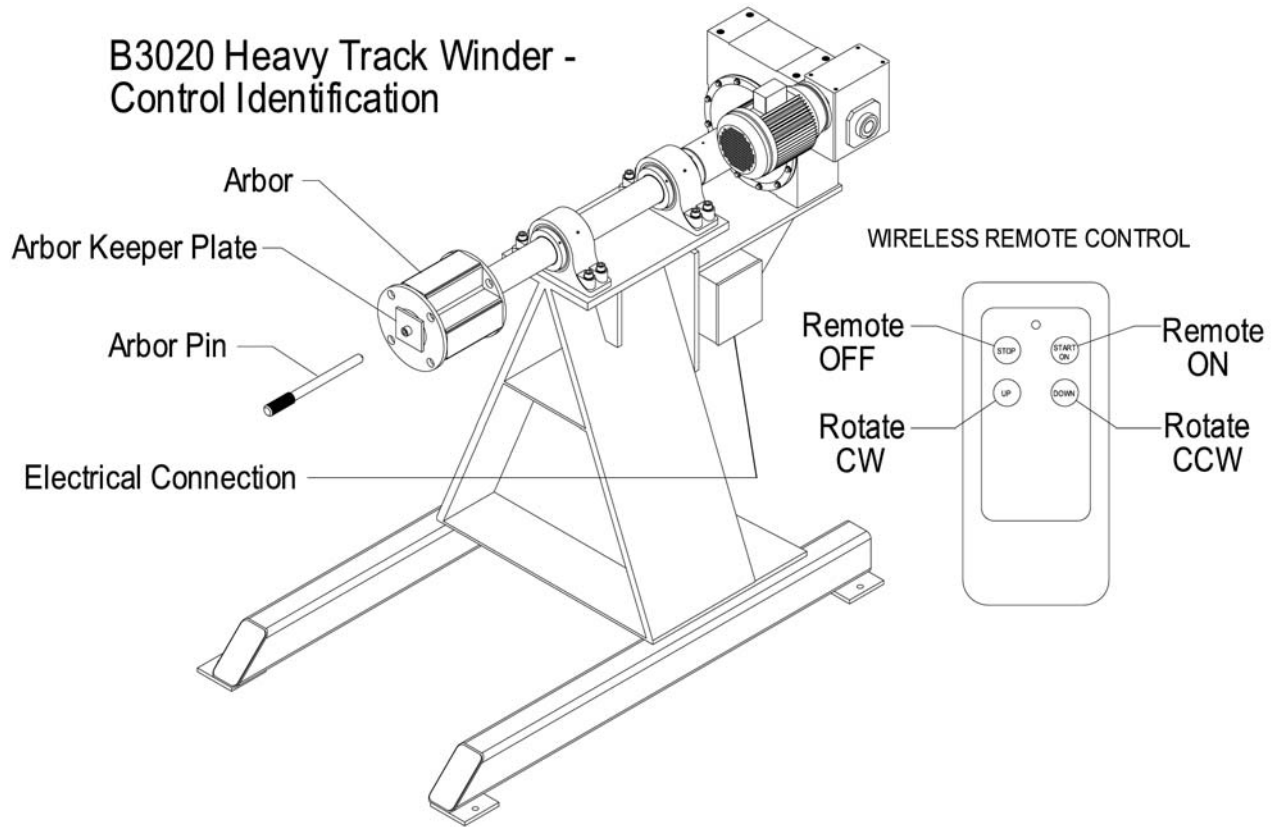

Arbor – The Arbor rotates to wind the track chain.
The four hole sets attach the Arbor to a strap connected to the track chain.

Arbor Keeper Plate – The Arbor Keeper Plate holds the Arbor on the Track Winder.
Remove this to unload the Arbor and track chain when winding is complete.

Arbor Pin – The Arbor Pin connects the Arbor to a strap.

Electrical Connection – Three phase electrical supply to the Track Winder is connected here.

Wireless Remote Control –

START / ON – Enables the Wireless Remote Control

STOP – Disables the Wireless Remote Control

UP – Turns the Arbor clockwise

DOWN – Turns the Arbor counter-clockwise



W1222 LINDEN ROAD, IXONIA, WISCONSIN 53036 USA

Phone: 800-248-8405 or 262-567-3993 • Fax: 262-567-4307 www.wtcmachinery.com

MANUFACTURERS/BENEFICIARY'S WARRANTY CERTIFICATE WTC MACHINERY, LLC WARRANTY

WTC MACHINERY, LLC warrants its products to be free from defects in material and workmanship under normal use and service for a period of twelve (12) months after date of shipment. WTC MACHINERY, LLC undertakes to be responsible for any defect that may arise due to faulty raw materials, design, workmanship and defective parts and to replace them without extra cost. Freight charges are the customer's responsibility. Our warranty is not transferable.

WTC MACHINERY, LLC shall have the option of requiring the return of all parts claimed defective. Parts proved to be defective, due to defect in workmanship and/or material, shall be either repaired or replaced free of charge, F.O.B. our designated factory. All parts warranty claims are subject to inspection by WTC MACHINERY, LLC and acceptance at the factory

Our warranty does not obligate us to bear the cost of labor or transportation charges in connection with the replacement or repair of defective parts and the removal and/or remounting of the parts repaired or replaced under this warranty, unless specifically authorized in writing by WTC MACHINERY, LLC. All parts returned to the factory must be shipped freight prepaid; no collect freight will be accepted by the factory. Forms authorizing such returns for inspection must accompany all returns.

This warranty shall not apply to products not manufactured by WTC MACHINERY, LLC.

Outside purchased equipment and accessories (not of WTC manufacture) are warranted only to the extent of the original equipment manufacturer's warranty and subject to their allowance to WTC MACHINERY, LLC. In this respect, our warranty obligations must conform and be limited to the warranty extended to WTC MACHINERY, LLC by its suppliers as extended to the customer.

We shall, in no event, be liable for consequential damages or contingent liability arising out of the failure of any unit or part to operate properly, or that is subject to:

- Ordinary operating wear, abuse, misuse, or overloading;
- Repairs or alterations by parties other than WTC MACHINERY, LLC;
- The use of improper fluids, contaminated fluids or improper filtering;
- The use of improper voltage hookup in the electrical connections of any equipment;
- Negligence, accident or damages due to deterioration during periods of storage by the purchaser prior to installation and operation;
- Damages occurred in shipment after leaving factory en route to customers' delivery point, as title to equipment passes to customer when loaded onboard for shipment, f.o.b. factory, and customer must place his own claim against damaged goods directly to the shipping company and not against WTC MACHINERY, LLC, its factory, or any of its personnel.
- Damages due to circumstances beyond the control of WTC MACHINERY, LLC and in connection with fulfilling any obligation under this warranty.

To the maximum extent permitted by applicable law, in no event shall WTC Machinery, LLC be liable for indirect, special, incidental or consequential damages resulting from personal injury, loss of business profits or business interruption from the use of its products, or from the inability to use its products.

This warranty is exclusive and is in lieu of all other expressed and implied warranties, including but not limited to implied warranties or merchantability and fitness for a particular purpose. WTC MACHINERY, LLC shall not be subject to any other obligations or liabilities whatsoever with respect to equipment manufactured or supplied by WTC MACHINERY, LLC, or services rendered to it.