



WTC MACHINERY Engineered to perform. Built to last.

WTC Machinery is a global leader in designing and building machinery and tooling for heavy equipment repair facilities.

SCRS

Overview

The SCRS Small Cylinder Repair Stand provides a stable platform for servicing hydraulic cylinders. The SCRS is a space-saving option for disassembly and nut-busting on small and medium rod eye style hydraulic cylinders. The unique frame design allows barrel storage on top of the unit, making the maximum use of available shop space.

Using the self-contained hydraulic system, the SCRS loosens and tightens piston nuts up to 20,000 lb-ft (27,100 N-m).



B2888-001 SCRS Small Cylinder Bench
and B3572 Square Nut Socket (Optional)

Specifications:

Maximum Cylinder Weight:	8000 lbs (3650 kg)
Maximum Barrel Diameter:	11 1/2 in (292 mm)
Maximum Cylinder Length:	109 in (2,76m)
Maximum Rod Eye Width:	8.8 in (225 mm)
Maximum Piston Nut (Across Flats):	6.3 in (162 mm)
Maximum Torque:	20,000 lb-ft (27,100 N-m)

Electrical

Power Requirements:	2 Hp (1.5 kW)
Standard Voltages:	120/60, 220/50, 230/60 Single-Phase

Small Hydraulic Cylinder Bench - Part Identification

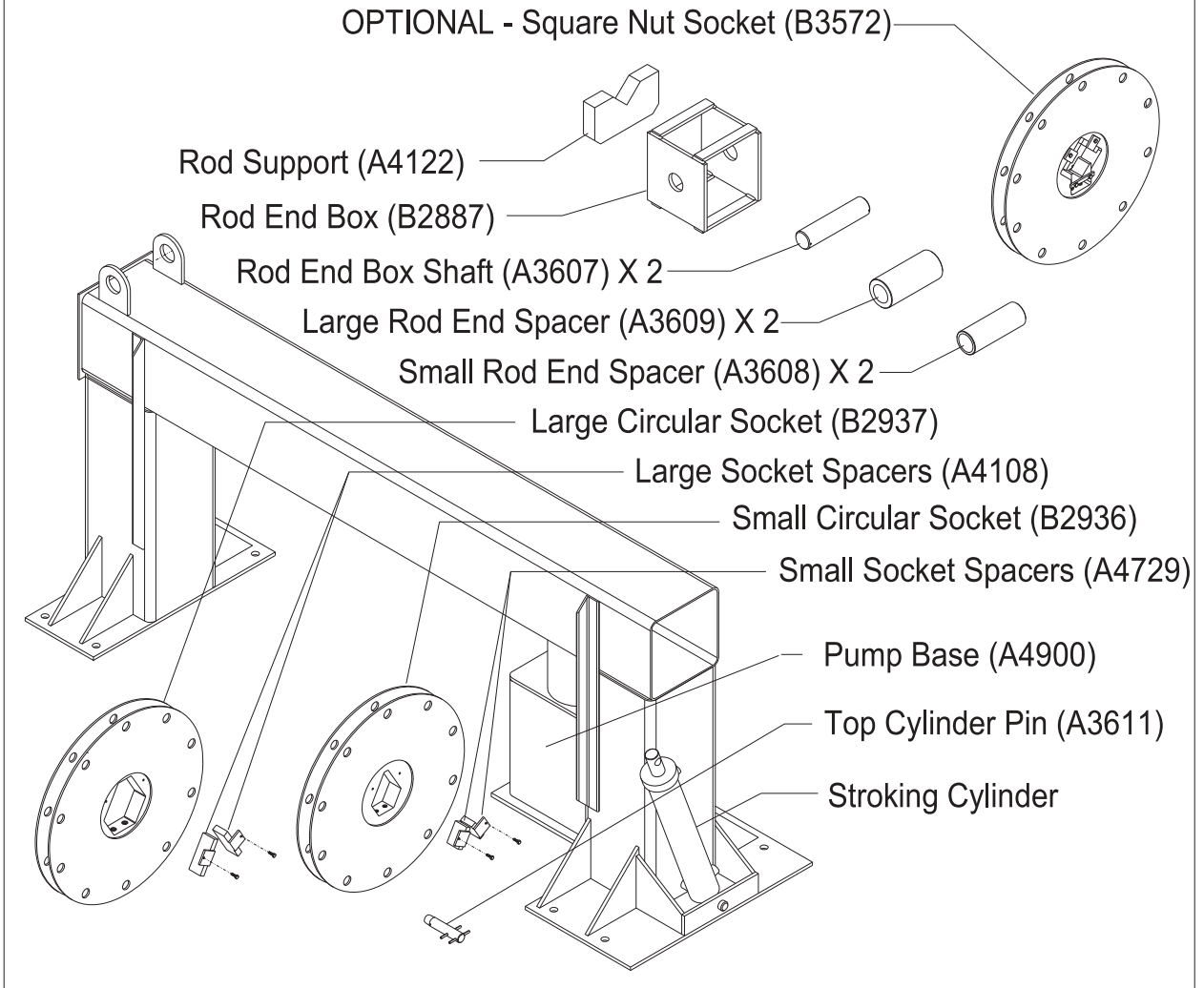

SCRS Hydraulic Power Supply

