

SECTION 6 – MPP150 Portable Pin Press Tooling

⚠ WARNING!

The MPP150 Portable Pin Press generates high forces, which present a risk of crush damage and flying debris. Only trained personnel familiar with its operation should use the MPP150. Always make sure the MPP150 and tooling are aligned and centered with track components before pressing. Always wear eye protection when operating the MPP150. Always keep clear of moving parts when the MPP150 is in use.

⚠ CAUTION!

Track condition affects the disassembly force, and some track models may exceed the capacity of the MPP150. It is the operator's responsibility to determine whether the MPP150 is adequate for a particular track.

The Tool Chart (starting on page 14) show the correct tooling for most crawler track models. For track models not listed, the drawing (below) shows the size ranges for Forcing Pins, Pin Adapters and Backing Bushing. See www.WTCmachinery.com for updated to tool charts.

Forcing Pins		
Item	Part Number	Description
1	B3632	Long 2.375 Thread-in Pin
2	B3631	Short 2.375 Thread-in Pin
3	B3607	Long 2.000 Thread-in Pin
4	B3608	Short 2.000 Thread-in Pin
5	B3815	1.750 Thread-in Pin Tool
6	B3635	1.250 Thread-in Pin Tool
7	A3537	Medium Pin Tool
8	A3536	Small Pin Tool

MPP150 Backing Bushings		
Item	Part Number	Description
9	A3541-001	Extra Large Backing Bushing
10	A3541	Large Backing Bushing
11	A3540	Medium Backing Bushing
12	A3539	Small Backing Bushing
13	A4157	Extra-Large Backing Bushing

Pin Adapters		
Item	Part Number	Min/Max Pin Dia.
20	50-007-001	1.97" to 2.22" (50,0 to 56,3 mm)
19	50-007-002	1.72" to 1.97" (43,6 to 50,0 mm)
18	50-007-003	1.60" to 1.72" (40,7 to 43,6 mm)
16	50-007-004	1.34" to 1.47" (34,1 to 37,3 mm)
15	50-007-005	1.22" to 1.34" (30,9 to 34,1 mm)
24	50-007-006	1.09" to 1.22" (27,7 to 30,9 mm)
14	50-007-007	0.94" to 1.09" (23,8 to 27,7 mm)
13	50-007-008	0.84" to 0.94" (21,4 to 23,8 mm)
17	50-007-010	1.47" to 1.60" (37,3 to 40,7 mm)
21	50-021-1	2.00" to 2.25" (50 to 57mm)
22	50-021-2	2.25" to 2.50" (57 to 63mm)
23	50-021-3	2.50" to 2.75" (63 to 70mm)

Misc. Adapters		
Item	Part Number	Description
24	*A3535	Small Pin Tool Holder
25	*B2866	Cylinder-Side Tooling
26	50-008-002	Pin Adapter Holder
27	*50-008-001	Pin Assembly Tool
28	Pin Ass'y Tool	See Tooling Chart
29	*B2867	Backing Bar-Side
30	529-522	SHCS 1/4-20 X 1 1/4
31	50-020	Large Track Pin Holder

* Items Included With MPP150

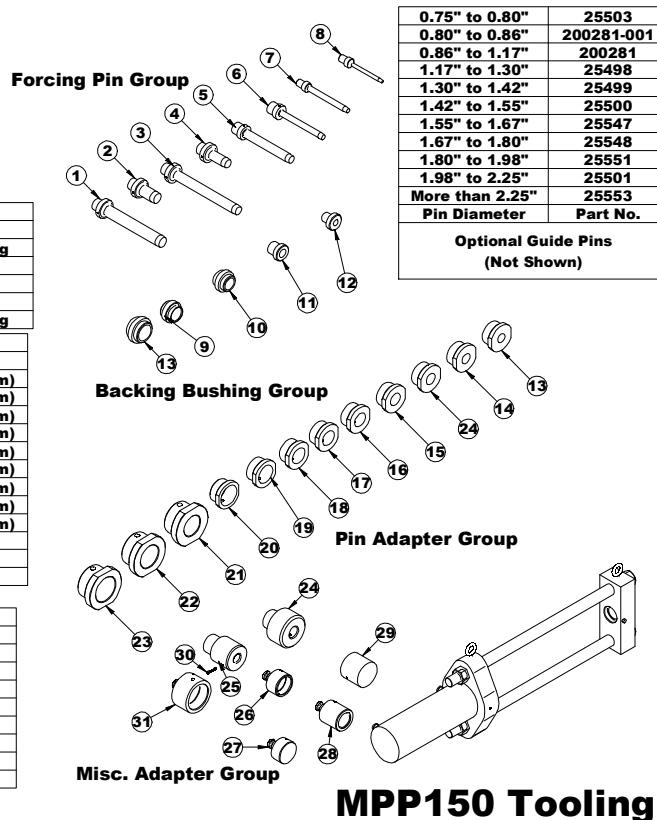

Disassembling large track models - those with high pressing forces and long pin lengths - require pairs of Pin Tools. Use the short "Starter" Pin Tool to make the initial push, and then switch to the long "Finishing" Pin Tool to complete pressing out the pin.

**CYLINDER-SIDE ADAPTERS
ALL MODELS**

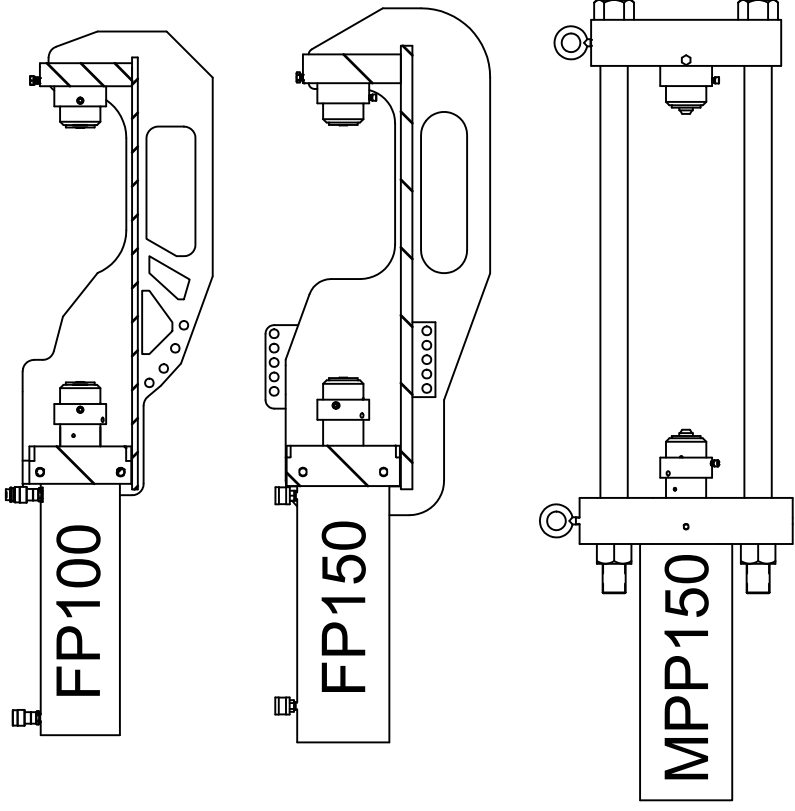
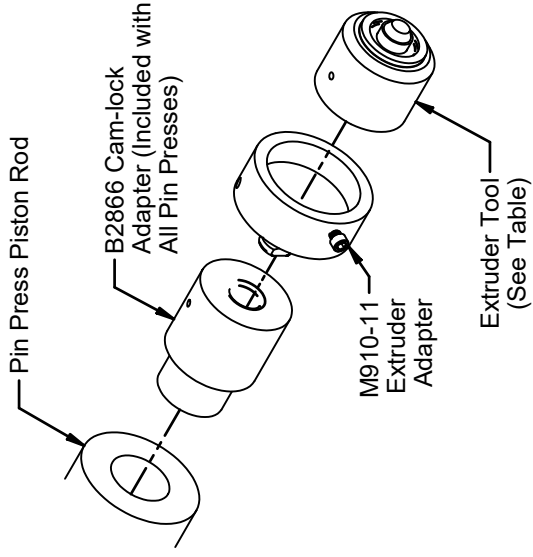

**BACK-SIDE ADAPTERS
FP100, FP150, MPP150**

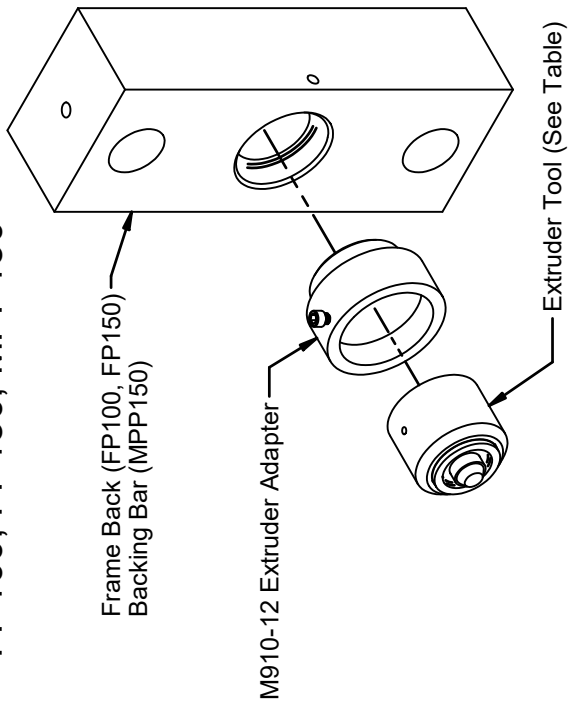

**BACK-SIDE ADAPTERS
FP250, MPP250**

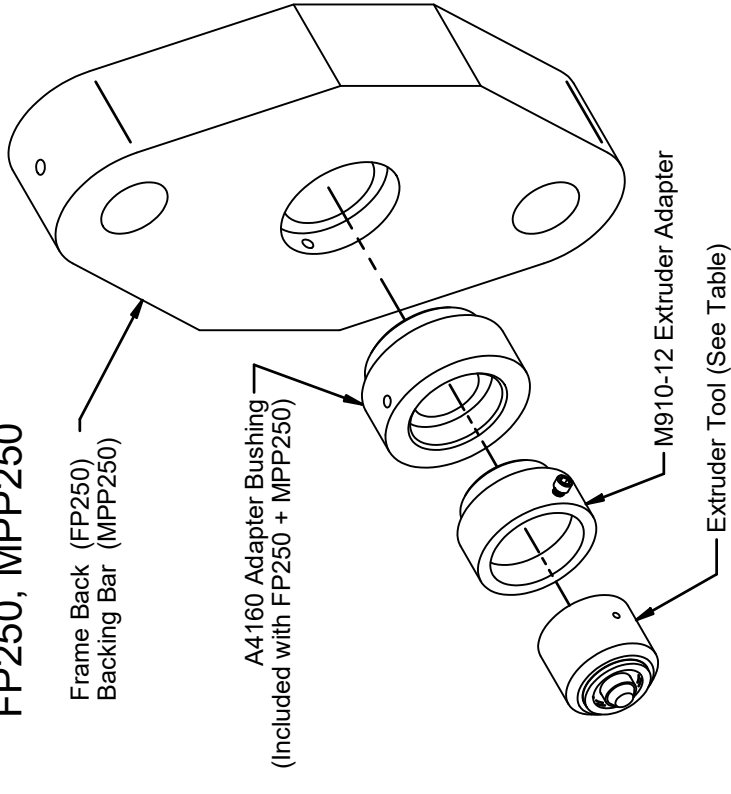

TRACK	CATERPILLAR PPR EXTRUDER TOOL	BERCO BPR2 EXTRUDER TOOL
D8N/R/T	M910-010	M910-010B
D9N/R/T	M910-1	M910-1B
D10 /N/R/T	M910-2*	M910-2B*
D11N/R/T	M910-3**	M910-3B**

Note: Extruder Tools Sold Individually - 2 Required

* - Exceeds FP100 Capacity

** - Exceeds FP100, FP150 and MPP150 Capacity



WTC Machinery, LLC
W1222 LINDEN ROAD
IXONIA, WISCONSIN 53036 USA

THIS DRAWING IS THE PROPERTY OF
WTC MACHINERY LLC.
DO NOT USE, DISTRIBUTE OR COPY
WITHOUT EXPRESS PERMISSION

BREAK ALL SHARP EDGES
DO NOT SCALE DRAWING

TOLERANCES UNLESS OTHERWISE SPECIFIED
FABRICATED DIMENSIONS +/- .1/16
FRACTIONAL DIMENSIONS +/- .1/64
DECIMAL DIMENSIONS +/- .010
INSIDE RADIUS .1/32
ANGULAR DIMENSIONS +/- .1/2
SURFACE FINISH 125

NEXT ASSEMBLY
FP / MPP Portable Pin Presses

USED ON
Caterpillar PPR Track Chains

TITLE
Caterpillar PPR Tracks
Pin Press Extruder Tools and Adapters

SHEET
DRAWN
Solid Edge

DATE 22.05.10
WGT N/A

SIZE
B

DRAWING NUMBER
FP/MPP-ETA

REV
A

CYLINDER-SIDE ADAPTERS - ALL MODELS

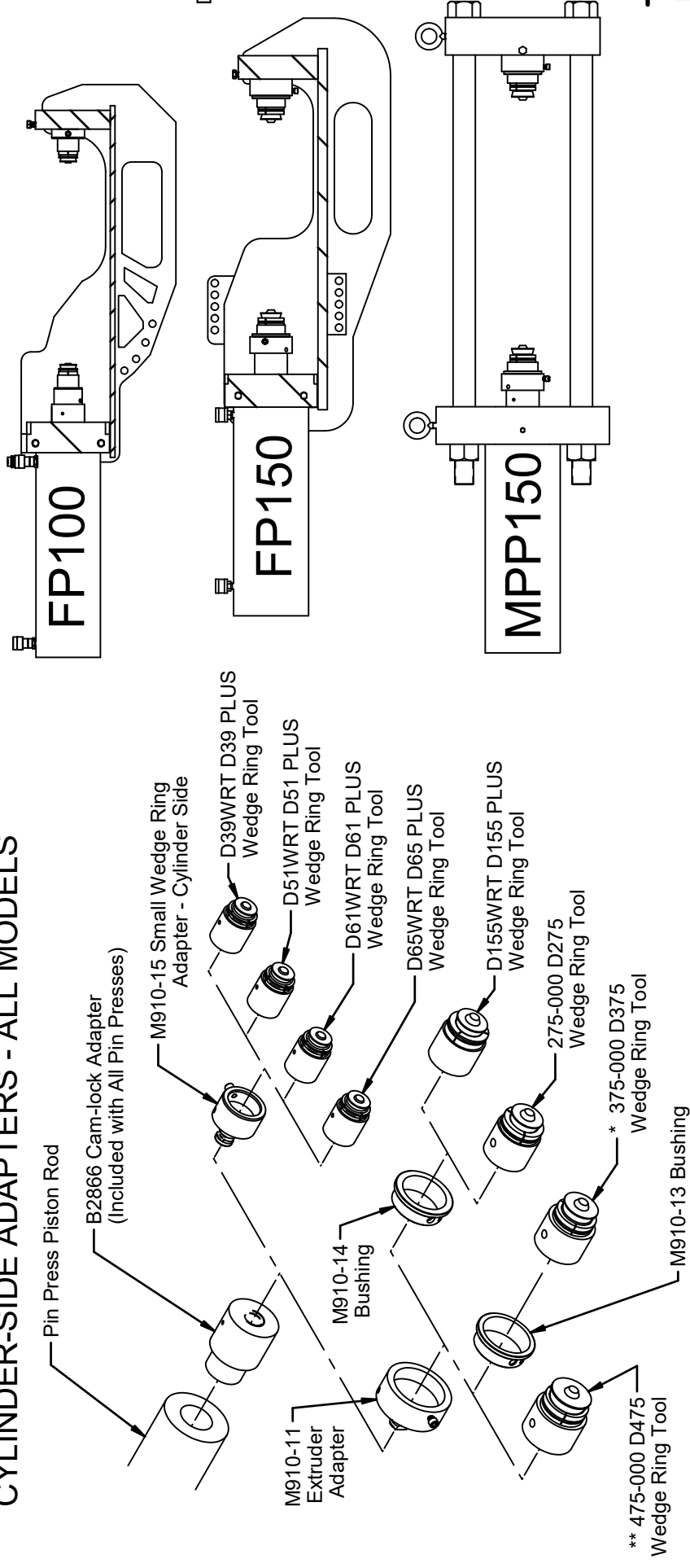

** 475-000 D475
Wedge Ring Tool

* 375-000 D375
Wedge Ring Tool

BACK-SIDE ADAPTERS - FP100, FP150, MPP150

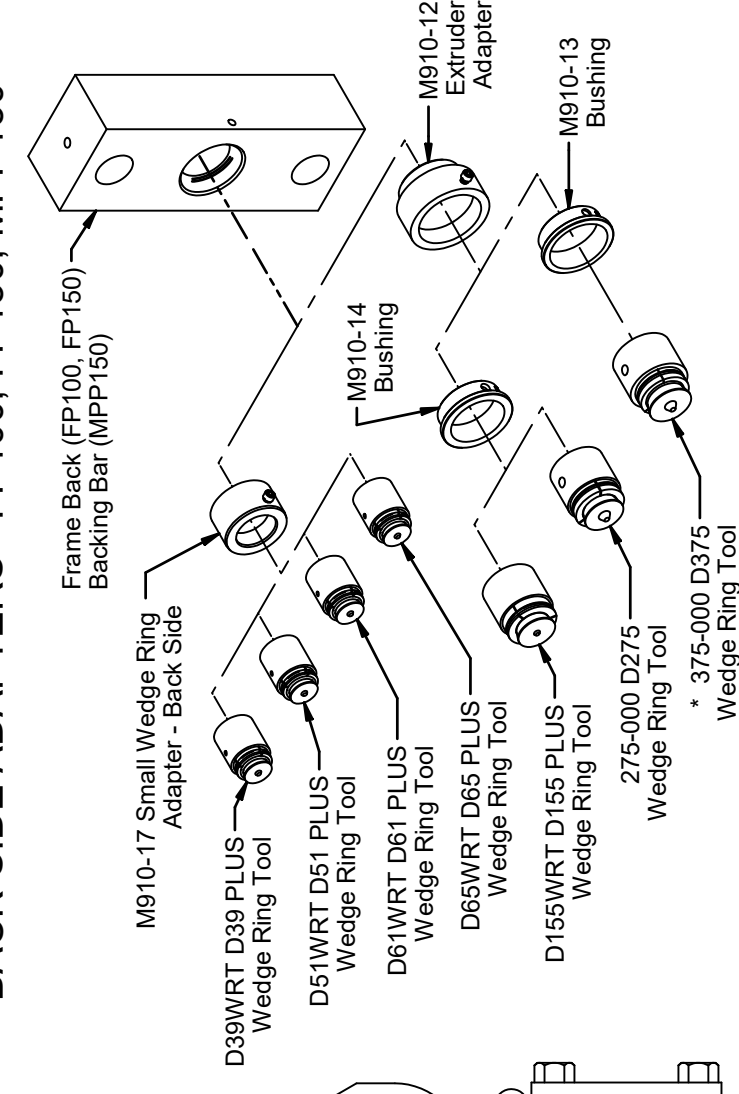

* 375-000 D375
Wedge Ring Tool

BACK-SIDE ADAPTERS - FP250, MPP250

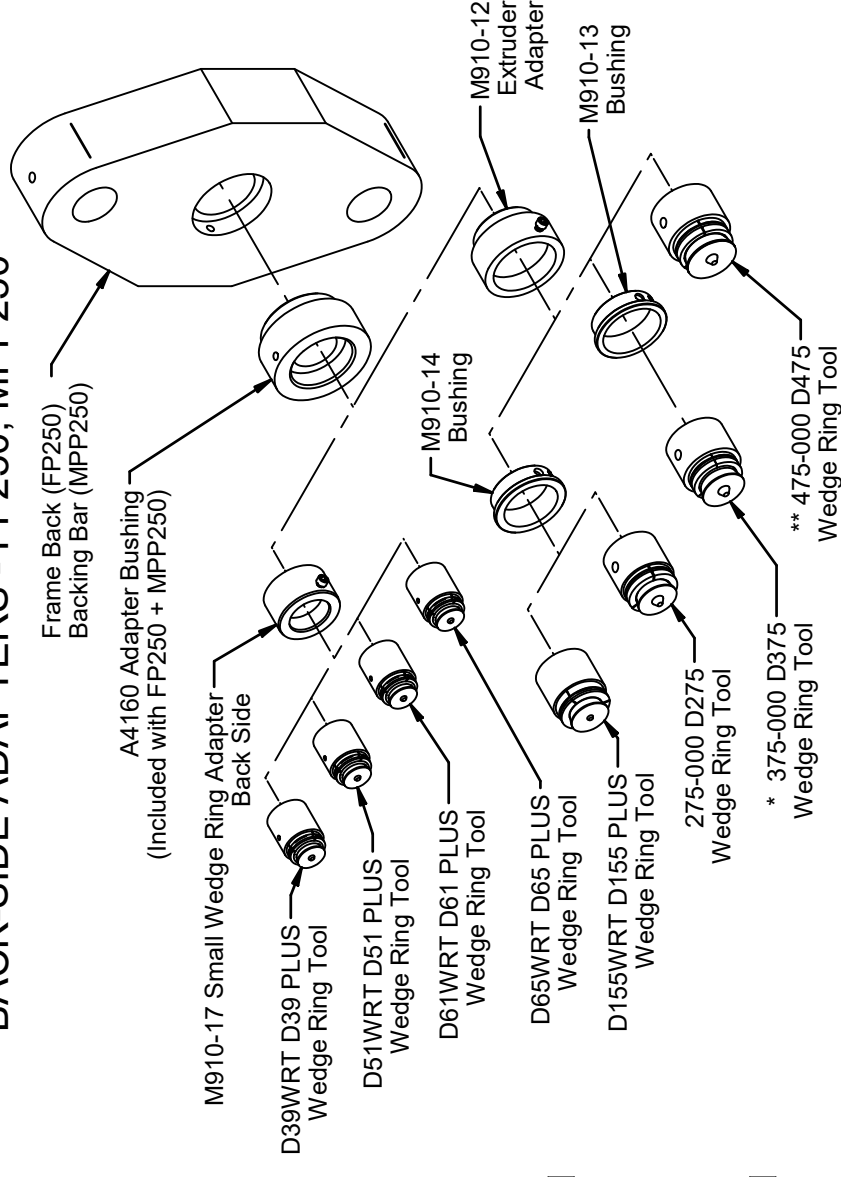

* 375-000 D375
Wedge Ring Tool

** 475-000 D475
Wedge Ring Tool

Note: Wedge Ring Tools Sold in Sets
 Each set includes -
 - one Large End Tool (Rubber Plug end)
 - one Small End Tool (Plastic Plug end)

* Exceeds Capacity of FP100

** Exceeds Capacity of FP100, FP150 and MPP150

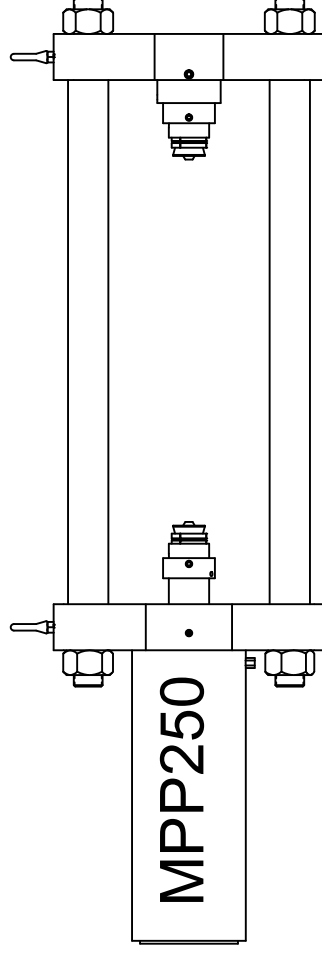
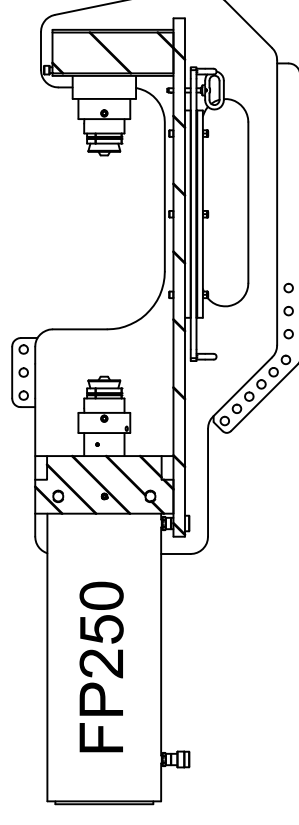
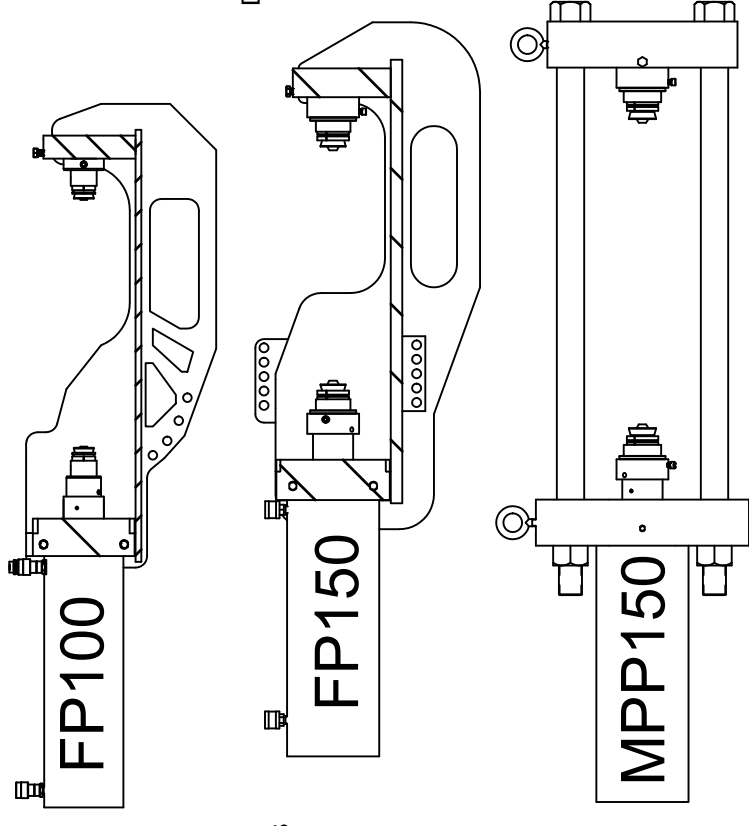

WTC Machinery, LLC

W1222 LINDEN ROAD
 IXONIA, WISCONSIN 53036 USA

THIS DRAWING IS THE PROPERTY OF
 WTC MACHINERY, LLC.
 DO NOT USE, DISTRIBUTE OR COPY
 WITHOUT EXPRESS PERMISSION
 BREAK ALL SHARP EDGES
 DO NOT SCALE DRAWING

TOLERANCES UNLESS
 OTHERWISE SPECIFIED
 FABRICATED DIMENSIONS +/- .1/16
 FRACTIONAL DIMENSIONS +/- .1/64
 DECIMAL DIMENSIONS +/- .010
 INSIDE RADII 1/32
 ANGULAR DIMENSIONS +/- .1/2
 SURFACE FINISH 125

NEXT ASSEMBLY
 FP / MPP Portable Pin Presses

USED ON
 Komatsu Wedge Ring Track Chains

TITLE
 Komatsu Wedge Ring Tracks

SHEET
 Pin Press Wedge Ring Tools and Adapters

DATE	22.05.10	SIZE	B	DRAWING NUMBER	REV
WGT	N/A			FP/MPP-WRTA	A



**WTC Machinery
MPP 150 Tooling Chart**

6/9/2022

Make	Model	Comments	Type	Pin Dimensions			Disassembly Tools		Assembly Tools			
				Dia	Length	Pitch	Pin Tool	Back. Bush.	Forcing Pin	PAT (2)	Pin Holder	Bushing
CASE	350		FLUSH	0.99	5.22	5.88	A3536	A3539	200281	915068	50-008-002	50-007-007
CASE	400		FLUSH	0.99	5.22	5.88	A3536	A3539	200281	915068	50-008-002	50-007-007
CASE	420		FLUSH	0.99	5.22	5.88	A3536	A3539	200281	915068	50-008-002	50-007-007
CASE	450			1.06	5.38	5.88	A3536	A3539	200281	915225	50-008-002	50-007-007
CASE	450		FLUSH	1.19	5.38	5.75	A3536	A3540	25498	915066	50-008-002	50-007-006
CASE	500		FLUSH	0.99	5.22	5.88	A3536	A3539	200281	915068	50-008-002	50-007-007
CASE	550	JAK0013968 & DN	SEALED	1.13	6.46	6.00	A3536	A3540	200281	915066	50-008-002	50-007-006
CASE	550		SEALED	1.13	6.58	6.29	A3536	A3540	200281	915144	50-008-002	50-007-006
CASE	550		SALT	1.13	6.58	6.29	A3536	A3540	200281	915144	50-008-002	50-007-006
CASE	560		FLUSH	0.99	5.22	5.88	A3536	A3539	200281	915068	50-008-002	50-007-007
CASE	600			1.06	5.38	5.88	A3536	A3539	200281	915225	50-008-002	50-007-007
CASE	650		SEALED	1.32	7.22	6.73	A3537	A3540	25499	915011	50-008-002	50-007-005
CASE	650		SALT	1.32	7.22	6.74	A3537	A3540	25499	915158	50-008-002	50-007-005
CASE	700	S/N 7070351 & DN	RECESSED	1.25	6.50	6.25	A3536	A3540	25498	915056	50-008-002	50-007-005
CASE	750		RECESSED	1.38	6.94	6.25	B3635	A3540	25499	915069	50-008-002	50-007-004
CASE	800		RECESSED	1.25	6.50	6.25	A3536	A3540	25498	915056	50-008-002	50-007-005
CASE	850		SEALED	1.38	6.94	6.25	B3635	A3540	25499	915009	50-008-002	50-007-004
CASE	1000	HD	RECESSED	1.38	6.94	6.25	B3635	A3540	25499	915069	50-008-002	50-007-004
CASE	1000		RECESSED	1.25	6.50	6.25	A3536	A3540	25498	915056	50-008-002	50-007-005
CASE	1000		SEALED	1.38	6.94	6.25	B3635	A3540	25499	915009	50-008-002	50-007-004
CASE	1150		RECESSED	1.38	6.94	6.25	B3635	A3540	25499	915069	50-008-002	50-007-004
CASE	1150		SEALED	1.38	6.94	6.25	B3635	A3540	25499	915009	50-008-002	50-007-004
CASE	1150		SEALED	1.38	6.94	6.25	B3635	A3540	25499	915011	50-008-002	50-007-004
CASE	1450		SEALED	1.75	9.08	8.02	B3635	A3541	25548	915070	50-008-002	50-007-002
CASE	1550		SEALED	1.75	9.06	8.02	B3635	A3541	25548	915226	50-008-002	50-007-002
CASE	1550		SALT	1.75	9.06	8.02	B3635	A3541	25548	915006	50-008-002	50-007-002
CASE	1150B		SEALED	1.50	8.10	6.68	B3635	A3540	25500	915067	50-008-002	50-007-010
CASE	1150D	7310051 & PRIOR	SEALED	1.44	8.11	6.68	B3635	A3540	25500	915052	50-008-002	50-007-004
CASE	1150D	7310051 & PRIOR	SALT	1.44	8.11	6.68	B3635	A3540	25500	915052	50-008-002	50-007-004
CASE	1150E		SALT	1.44	8.11	6.68	B3635	A3540	25500	915052	50-008-002	50-007-004
CASE	1150E		SEALED	1.44	8.11	6.68	B3635	A3540	25500	915052	50-008-002	50-007-004
CASE	1155D	7311001 & PRIOR	SALT	1.44	8.11	6.68	B3635	A3540	25500	915052	50-008-002	50-007-004
CASE	1155D	7311001 & PRIOR	SEALED	1.44	8.11	6.68	B3635	A3540	25500	915052	50-008-002	50-007-004
CASE	1155E		SALT	1.44	8.11	6.68	B3635	A3540	25500	915052	50-008-002	50-007-004
CASE	1155E		SEALED	1.44	8.11	6.68	B3635	A3540	25500	915052	50-008-002	50-007-004
CASE	1450B		SEALED	1.75	9.08	8.02	B3635	A3541	25548	915070	50-008-002	50-007-002
CASE	1450B	S/N 8383001 & UP	SEALED	1.75	9.06	8.02	B3635	A3541	25548	915226	50-008-002	50-007-002
CASE	1450B		SALT	1.75	9.06	8.02	B3635	A3541	25548	915006	50-008-002	50-007-002
CASE	1455B		SEALED	1.75	9.08	8.02	B3635	A3541	25548	915070	50-008-002	50-007-002
CASE	1455B	S/N 8480001 & UP	SEALED	1.75	9.06	8.02	B3635	A3541	25548	915226	50-008-002	50-007-002
CASE	1455B		SALT	1.75	9.06	8.02	B3635	A3541	25548	915006	50-008-002	50-007-002
CASE	310G		FLUSH	0.99	5.22	5.88	A3536	A3539	200281	915068	50-008-002	50-007-007
CASE	350B		SEALED	0.99	5.22	5.88	A3536	A3539	200281	915224	50-008-002	50-007-007
CASE	450A	S/N 3030801 & UP	SEALED	1.25	6.54	6.00	A3537	A3540	25498	915069	50-008-002	50-007-005
CASE	450B		SEALED	1.25	6.54	6.00	A3537	A3540	25498	915069	50-008-002	50-007-005
CASE	450C		SALT	1.13	6.46	6.00	A3536	A3540	200281	915046	50-008-002	50-007-006
CASE	450C		SEALED	1.13	6.46	6.00	A3536	A3540	200281	915066	50-008-002	50-007-006



**WTC Machinery
MPP 150 Tooling Chart**

6/9/2022

Make	Model	Comments	Type	Pin Dimensions			Disassembly Tools		Assembly Tools			
				Dia	Length	Pitch	Pin Tool	Back. Bush.	Forcing Pin	PAT (2)	Pin Holder	Bushing
CASE	455C		SALT	1.13	6.46	6.00	A3536	A3540	200281	915046	50-008-002	50-007-006
CASE	550E		SEALED	1.13	6.58	6.29	A3536	A3540	200281	915144	50-008-002	50-007-006
CASE	550E		SALT	1.13	6.58	6.29	A3536	A3540	200281	915144	50-008-002	50-007-006
CASE	550G	w/ Floating Bushing	SEALED	1.13	6.58	6.29	A3536	A3540	200281	915144	50-008-002	50-007-006
CASE	850B		SEALED	1.38	6.94	6.25	B3635	A3540	25499	915009	50-008-002	50-007-004
CASE	850D		SALT	1.32	7.22	6.25	A3537	A3540	25499	915011	50-008-002	50-007-005
CASE	850D		SEALED	1.38	6.94	6.25	B3635	A3540	25499	915011	50-008-002	50-007-004
CASE	850D		SEALED	1.32	7.22	6.73	A3537	A3540	25499	915011	50-008-002	50-007-005
CASE	850D		SALT	1.32	7.22	6.74	A3537	A3540	25499	915158	50-008-002	50-007-005
CASE	850E	AFTER 4-1-89	SEALED	1.32	7.22	6.73	A3537	A3540	25499	915011	50-008-002	50-007-005
CASE	850E	AFTER 4-1-89	SALT	1.32	7.22	6.74	A3537	A3540	25499	915158	50-008-002	50-007-005
CASE	850G		SEALED	1.32	7.22	6.73	A3537	A3540	25499	915011	50-008-002	50-007-005
CASE	850G		SALT	1.32	7.22	6.74	A3537	A3540	25499	915158	50-008-002	50-007-005
CASE	850H		SEALED	1.32	7.22	6.73	A3537	A3540	25499	915011	50-008-002	50-007-005
CASE	850H		SALT	1.32	7.22	6.74	A3537	A3540	25499	915158	50-008-002	50-007-005
CASE	850K		SEALED	1.32	7.22	6.73	A3537	A3540	25499	915011	50-008-002	50-007-005
CASE	850K		SALT	1.32	7.22	6.74	A3537	A3540	25499	915158	50-008-002	50-007-005
CASE	855D		SALT	1.32	7.22	6.25	A3537	A3540	25499	915011	50-008-002	50-007-005
CASE	855D		SEALED	1.38	6.94	6.25	B3635	A3540	25499	915011	50-008-002	50-007-004
CASE	855D	AFTER 4-1-89	SEALED	1.32	7.22	6.73	A3537	A3540	25499	915011	50-008-002	50-007-005
CASE	855D	AFTER 4-1-89	SALT	1.32	7.22	6.74	A3537	A3540	25499	915158	50-008-002	50-007-005
CATERPILLAR	30		RECESS	1.31	7.00	6.74	A3537	A3540	25499	915011	50-008-002	50-007-005
CATERPILLAR	215	w/ 9/16 BOLT	SEALED	1.32	6.37	6.74	A3537	A3540	25499	915089	50-008-002	50-007-005
CATERPILLAR	215	w/ 5/8 BOLT	SEALED	1.31	7.22	6.74	A3537	A3540	25499	915011	50-008-002	50-007-005
CATERPILLAR	219		SEALED	1.44	8.12	7.48	B3635	A3540	25500	915052	50-008-002	50-007-004
CATERPILLAR	225	EXC	SEALED	1.31	7.22	6.74	A3537	A3540	25499	915011	50-008-002	50-007-005
CATERPILLAR	225		SEALED	1.25	9.06	7.98	A3537	A3540	25498	915003	50-008-002	50-007-005
CATERPILLAR	227		SEALED	1.25	9.06	7.98	A3537	A3540	25498	915003	50-008-002	50-007-005
CATERPILLAR	229		SEALED	1.25	9.06	7.98	A3537	A3540	25498	915003	50-008-002	50-007-005
CATERPILLAR	235	EXC	SEALED	1.25	9.06	7.98	A3537	A3540	25498	915003	50-008-002	50-007-005
CATERPILLAR	235		SEALED	1.88	9.88	8.50	B3815	A3541	25551	915012	50-008-002	50-007-002
CATERPILLAR	245	EXC	SEALED	2.25	11.26	10.25	B3607/8	A3541	25553	915005	50-020	50-021-2
CATERPILLAR	311	EXC	SEALED	1.32	7.01	6.75	A3537	A3540	25499	915059	50-008-002	50-007-005
CATERPILLAR	312	EXC	SEALED	1.32	7.01	6.75	A3537	A3540	25499	915059	50-008-002	50-007-005
CATERPILLAR	315	EXC	SEALED	1.44	8.15	7.48	B3635	A3540	25500	915140	50-008-002	50-007-004
CATERPILLAR	317	EXC	SEALED	1.44	8.15	7.48	B3635	A3540	25500	915140	50-008-002	50-007-004
CATERPILLAR	320	EXC	SEALED	1.44	8.15	7.48	B3635	A3540	25500	915140	50-008-002	50-007-004
CATERPILLAR	322	EXC	SEALED	1.44	8.15	7.48	B3635	A3540	25500	915140	50-008-002	50-007-004
CATERPILLAR	325	EXC	SEALED	1.65	9.06	8.00	B3635	A3541	25547L	915141	50-008-002	50-007-003
CATERPILLAR	330	EXC	SEALED	1.81	9.67	8.50	B3635	A3541	25551	915015	50-008-002	50-007-002
CATERPILLAR	345	EXC	SEALED	2.00	11.44	8.50	B3815	A3541	25551	915142	50-008-002	50-007-001
CATERPILLAR	350		SEALED	2.00	11.44	9.00	B3815	A3541	25551	915001	50-008-002	50-007-001
CATERPILLAR	365	EXC	SEALED	2.25	12.24	10.25	B3607/8	A3541	25553	915139	50-020	50-021-2
CATERPILLAR	375	EXC	SEALED	2.25	12.24	10.25	B3607/8	A3541	25553	915139	50-020	50-021-2
CATERPILLAR	390	EXC	SEALED	2.17	12.40	10.25	B3607/8	A3541	25501L	915284	50-008-002	50-007-001
CATERPILLAR	561	PIPELAYER	SEALED	1.44	8.13	6.91	B3635	A3540	25500	915009	50-008-002	50-007-004
CATERPILLAR	571		SEALED	1.75	9.88	7.98	B3635	A3541	25548	915012	50-008-002	50-007-002



**WTC Machinery
MPP 150 Tooling Chart**

6/9/2022

Make	Model	Comments	Type	Pin Dimensions			Disassembly Tools		Assembly Tools			
				Dia	Length	Pitch	Pin Tool	Back. Bush.	Forcing Pin	PAT (2)	Pin Holder	Bushing
CATERPILLAR	572		SEALED	1.75	9.88	7.98	B3635	A3541	25548	915012	50-008-002	50-007-002
CATERPILLAR	572		SEALED	1.88	9.88	8.50	B3815	A3541	25551	915012	50-008-002	50-007-002
CATERPILLAR	578	PIPELAYER	SALT	1.88	9.88	8.50	B3815	A3541	25551	915006	50-008-002	50-007-002
CATERPILLAR	578		PPR	1.88	9.65	8.50	B3815	A3541	25551	915207	50-008-002	50-007-002
CATERPILLAR	583		SEALED	1.75	11.44	7.99	B3635	A3541	25548	915013	50-008-002	50-007-002
CATERPILLAR	589		PPR	2.00	10.77	9.00	B3815	A3541	25551	915253	50-008-002	50-007-001
CATERPILLAR	589	PIPELAYER	SALT	2.00	11.44	9.00	B3815	A3541	25551	915093	50-008-002	50-007-001
CATERPILLAR	594		SEALED	2.25	12.25	10.25	B3607/8	A3541	25553	915005	50-020	50-021-2
CATERPILLAR	931		SEALED	1.13	6.16	6.13	A3536	A3540	200281	915004	50-008-002	50-007-006
CATERPILLAR	931		SALT	1.13	6.16	6.13	A3536	A3540	200281	915082	50-008-002	50-007-006
CATERPILLAR	933		SEALED	1.13	6.16	6.13	A3536	A3540	200281	915004	50-008-002	50-007-006
CATERPILLAR	939		SALT	1.32	7.54	6.74	A3537	A3540	25499	915149	50-008-002	50-007-005
CATERPILLAR	941	w/ 5/8 BOLT	SEALED	1.31	7.22	6.74	A3537	A3540	25499	915011	50-008-002	50-007-005
CATERPILLAR	941	w/ 9/16 BOLT	SEALED	1.31	7.00	6.74	A3537	A3540	25499	915002	50-008-002	50-007-005
CATERPILLAR	941		SALT	1.31	7.22	6.74	A3537	A3540	25499	915052	50-008-002	50-007-005
CATERPILLAR	943	HI RAIL	SALT	1.32	7.22	6.74	A3537	A3540	25499	915002	50-008-002	50-007-005
CATERPILLAR	943	HI RAIL	SALT	1.31	7.22	6.74	A3537	A3540	25499	915052	50-008-002	50-007-005
CATERPILLAR	951		SALT	1.44	8.12	6.91	B3635	A3540	25500	915052	50-008-002	50-007-004
CATERPILLAR	951		SEALED	1.44	8.13	6.74	B3635	A3540	25500	915009	50-008-002	50-007-004
CATERPILLAR	953	HI RAIL	SALT	1.44	8.12	6.91	B3635	A3540	25500	915052	50-008-002	50-007-004
CATERPILLAR	953		SALT	1.44	8.12	6.91	B3635	A3540	25500	915052	50-008-002	50-007-004
CATERPILLAR	953	LGP	SALT	1.44	8.12	6.91	B3635	A3540	25500	915052	50-008-002	50-007-004
CATERPILLAR	955	HD	SEALED	1.44	8.13	6.74	B3635	A3540	25500	915009	50-008-002	50-007-004
CATERPILLAR	955		SEALED	1.25	9.06	7.98	A3537	A3540	25498	915003	50-008-002	50-007-005
CATERPILLAR	955		SALT	1.75	9.06	7.98	B3635	A3541	25548	915003	50-008-002	50-007-002
CATERPILLAR	963		SALT	1.75	9.06	7.98	B3635	A3541	25548	915003	50-008-002	50-007-002
CATERPILLAR	963	HI RAIL	SALT	1.75	9.06	7.98	B3635	A3541	25548	915003	50-008-002	50-007-002
CATERPILLAR	973	HI RAIL	SALT	1.88	9.88	8.50	B3815	A3541	25551	915201	50-008-002	50-007-002
CATERPILLAR	973		SALT	1.88	9.88	8.50	B3815	A3541	25551	915006	50-008-002	50-007-002
CATERPILLAR	973	HI RAIL	SALT	1.88	9.88	8.50	B3815	A3541	25551	915006	50-008-002	50-007-002
CATERPILLAR	973	LGP	SALT	1.88	9.88	8.50	B3815	A3541	25551	915006	50-008-002	50-007-002
CATERPILLAR	973		SEALED	1.88	9.88	8.50	B3815	A3541	25551	915012	50-008-002	50-007-002
CATERPILLAR	977	OPT FORMER	SEALED	1.44	8.13	6.91	B3635	A3540	25500	915009	50-008-002	50-007-004
CATERPILLAR	977		SEALED	1.44	8.13	6.74	B3635	A3540	25500	915009	50-008-002	50-007-004
CATERPILLAR	977		SALT	1.88	9.88	8.50	B3815	A3541	25551	915006	50-008-002	50-007-002
CATERPILLAR	977		SEALED	1.88	9.88	8.50	B3815	A3541	25551	915012	50-008-002	50-007-002
CATERPILLAR	983		SEALED	2.00	11.44	9.00	B3815	A3541	25551	915001	50-008-002	50-007-001
CATERPILLAR	5080		SEALED	2.25	12.24	10.25	B3607/8	A3541	25553	915139	50-020	50-021-2
CATERPILLAR	E70B		SEALED	0.95	5.51	5.32	A3536	A3539	200281	915129	50-008-002	50-007-007
CATERPILLAR	14A		SEALED	1.75	11.44	7.99	B3635	A3541	25548	915013	50-008-002	50-007-002
CATERPILLAR	17A		SEALED	1.75	9.88	7.98	B3635	A3541	25548	915012	50-008-002	50-007-002
CATERPILLAR	215A		SEALED	1.44	8.12	7.48	B3635	A3540	25500	915052	50-008-002	50-007-004
CATERPILLAR	225B	EXC	SEALED	1.44	8.12	7.48	B3635	A3540	25500	915052	50-008-002	50-007-004
CATERPILLAR	225C	EXC	SEALED	1.44	8.12	7.48	B3635	A3540	25500	915052	50-008-002	50-007-004
CATERPILLAR	231D		SEALED	1.25	9.06	7.98	A3537	A3540	25498	915003	50-008-002	50-007-005
CATERPILLAR	235D		SEALED	2.00	11.44	9.00	B3815	A3541	25551	915001	50-008-002	50-007-001
CATERPILLAR	245S		SEALED	2.00	11.44	9.00	B3815	A3541	25551	915001	50-008-002	50-007-001



**WTC Machinery
MPP 150 Tooling Chart**

6/9/2022

Make	Model	Comments	Type	Pin Dimensions			Disassembly Tools		Assembly Tools			
				Dia	Length	Pitch	Pin Tool	Back. Bush.	Forcing Pin	PAT (2)	Pin Holder	Bushing
CATERPILLAR	307C		GREASE	0.94	5.15	6.06	A3536	A3539	200281	915169	50-008-002	50-007-007
CATERPILLAR	312C	EXC	GREASE	1.32	7.00	6.75	A3537	A3540	25499	915059	50-008-002	50-007-005
CATERPILLAR	313B	EXC	SEALED	1.32	7.01	6.75	A3537	A3540	25499	915059	50-008-002	50-007-005
CATERPILLAR	314B	EXC	SEALED	1.32	7.01	6.75	A3537	A3540	25499	915059	50-008-002	50-007-005
CATERPILLAR	315B	EXC	GREASE	1.44	8.15	7.48	B3635	A3540	25500	915236	50-008-002	50-007-004
CATERPILLAR	315C	EXC	GREASE	1.44	8.15	7.48	B3635	A3540	25500	915170	50-008-002	50-007-004
CATERPILLAR	318C	EXC	GREASE	1.44	8.15	7.48	B3635	A3540	25500	915170	50-008-002	50-007-004
CATERPILLAR	320B	EXC	SEALED	1.44	8.15	7.48	B3635	A3540	25500	915140	50-008-002	50-007-004
CATERPILLAR	320C	EXC	GREASE	1.44	8.15	7.48	B3635	A3540	25500	915170	50-008-002	50-007-004
CATERPILLAR	322B	EXC	GREASE	1.44	8.15	7.48	B3635	A3540	25500	915236	50-008-002	50-007-004
CATERPILLAR	322C	EXC	GREASE	1.44	8.15	7.48	B3635	A3540	25500	915170	50-008-002	50-007-004
CATERPILLAR	325BL	EXC	SEALED	1.65	9.06	8.00	B3635	A3541	25547L	915141	50-008-002	50-007-003
CATERPILLAR	325C	EXC	GREASE	1.65	9.05	7.99	B3635	A3541	25547L	915141	50-008-002	50-007-003
CATERPILLAR	330B	EXC	SEALED	1.81	9.67	8.50	B3635	A3541	25551	915015	50-008-002	50-007-002
CATERPILLAR	330B	EXC	GREASE	1.81	9.67	8.50	B3635	A3541	25551	915185	50-008-002	50-007-002
CATERPILLAR	330C	EXC	SEALED	1.81	9.67	8.50	B3635	A3541	25551	915015	50-008-002	50-007-002
CATERPILLAR	345B	EXC	SALT	1.88	9.88	8.50	B3815	A3541	25551	915200	50-008-002	50-007-002
CATERPILLAR	345B		SEALED	1.88	9.88	8.50	B3815	A3541	25551	915012	50-008-002	50-007-002
CATERPILLAR	345BL	EXC	SALT	1.88	9.88	8.50	B3815	A3541	25551	915200	50-008-002	50-007-002
CATERPILLAR	365BL	EXC	SEALED	2.25	12.24	10.25	B3607/8	A3541	25553	915139	50-020	50-021-2
CATERPILLAR	385B	EXC	SEALED	2.25	13.19	10.25	B3607/8	A3541	25553L	915168	50-020	50-021-2
CATERPILLAR	561H	HD	SALT	1.42	8.45	6.74	B3635	A3540	25499	915145	50-008-002	50-007-004
CATERPILLAR	561H		SALT	1.32	7.54	6.74	A3537	A3540	25499	915149	50-008-002	50-007-005
CATERPILLAR	571A		SALT	1.88	9.88	8.50	B3815	A3541	25551	915006	50-008-002	50-007-002
CATERPILLAR	571A		SEALED	1.88	9.88	8.50	B3815	A3541	25551	915012	50-008-002	50-007-002
CATERPILLAR	583R	PIPELAYER	SALT	1.88	9.88	8.50	B3815	A3541	25551	915006	50-008-002	50-007-002
CATERPILLAR	933	CURRENT	SALT	1.13	6.16	6.13	A3536	A3540	200281	915082	50-008-002	50-007-006
CATERPILLAR	935B		SEALED	1.13	6.16	6.13	A3536	A3540	200281	915004	50-008-002	50-007-006
CATERPILLAR	935B		SALT	1.13	6.16	6.13	A3536	A3540	200281	915082	50-008-002	50-007-006
CATERPILLAR	935C		SALT	1.13	6.16	6.13	A3536	A3540	200281	915082	50-008-002	50-007-006
CATERPILLAR	951B		SEALED	1.44	8.13	6.91	B3635	A3540	25500	915009	50-008-002	50-007-004
CATERPILLAR	951B		SEALED	1.44	8.13	6.74	B3635	A3540	25500	915009	50-008-002	50-007-004
CATERPILLAR	951C		SEALED	1.44	8.13	6.91	B3635	A3540	25500	915009	50-008-002	50-007-004
CATERPILLAR	955K		SEALED	1.44	8.13	6.91	B3635	A3540	25500	915009	50-008-002	50-007-004
CATERPILLAR	977K		SEALED	1.75	9.88	7.98	B3635	A3541	25548	915012	50-008-002	50-007-002
CATERPILLAR	983		SALT	2.00	11.44	9.00	B3815	A3541	25551	915007	50-008-002	50-007-001
CATERPILLAR	AP1050		SEALED	1.13	6.16	6.13	A3536	A3540	200281	915004	50-008-002	50-007-006
CATERPILLAR	D10		PPR	2.25	11.97	10.25	B3607/8	A3541	25553	915240	50-020	50-021-2
CATERPILLAR	D10		SALT	2.25	12.25	10.25	B3607/8	A3541	25553	915063	50-020	50-021-2
CATERPILLAR	D10N		PPR	2.25	11.97	10.25	B3607/8	A3541	25553	915246	50-020	50-021-2
CATERPILLAR	D10N		SALT	2.25	12.25	10.25	B3607/8	A3541	25553	915104	50-020	50-021-2
CATERPILLAR	D10R		PPR	2.25	11.97	10.25	B3607/8	A3541	25553	915246	50-020	50-021-2
CATERPILLAR	D10R		SALT	2.25	12.25	10.25	B3607/8	A3541	25553	915104	50-020	50-021-2
CATERPILLAR	D10T		SALT	2.25	12.25	10.25	B3607/8	A3541	25553	915104	50-020	50-021-2
CATERPILLAR	D2		RECESS	1.13	6.16	6.13	A3536	A3540	200281	916040	50-008-002	50-007-006
CATERPILLAR	D2		SEALED	1.13	6.18	6.13	A3536	A3540	200281	915040	50-008-002	50-007-006
CATERPILLAR	D3		SEALED	1.13	6.16	6.13	A3536	A3540	200281	915004	50-008-002	50-007-006



**WTC Machinery
MPP 150 Tooling Chart**

6/9/2022

Make	Model	Comments	Type	Pin Dimensions			Disassembly Tools		Assembly Tools			
				Dia	Length	Pitch	Pin Tool	Back. Bush.	Forcing Pin	PAT (2)	Pin Holder	Bushing
CATERPILLAR	D3		SALT	1.13	6.16	6.13	A3536	A3540	200281	915082	50-008-002	50-007-006
CATERPILLAR	D3	EARLY	SALT	1.13	6.16	6.13	A3536	A3540	200281	915082	50-008-002	50-007-006
CATERPILLAR	D3		SALT	1.13	6.16	6.13	A3536	A3540	200281	915082	50-008-002	50-007-006
CATERPILLAR	D3	FORMER	SALT	1.13	6.16	6.13	A3536	A3540	200281	915082	50-008-002	50-007-006
CATERPILLAR	D3B		SEALED	1.13	6.16	6.13	A3536	A3540	200281	915004	50-008-002	50-007-006
CATERPILLAR	D3B		SALT	1.13	6.16	6.13	A3536	A3540	200281	915082	50-008-002	50-007-006
CATERPILLAR	D3C		SALT	1.13	6.16	6.13	A3536	A3540	200281	915082	50-008-002	50-007-006
CATERPILLAR	D3G		SEALED	1.13	6.16	6.13	A3536	A3540	200281	915004	50-008-002	50-007-006
CATERPILLAR	D3G		SALT	1.13	6.16	6.13	A3536	A3540	200281	915082	50-008-002	50-007-006
CATERPILLAR	D4		SEALED	1.31	7.00	6.74	A3537	A3540	25499	915002	50-008-002	50-007-005
CATERPILLAR	D4		RECESS	1.31	7.00	6.74	A3537	A3540	25499	915011	50-008-002	50-007-005
CATERPILLAR	D4	w/ 1/2 BOLT	SEALED	1.31	7.00	6.74	A3537	A3540	25499	915137	50-008-002	50-007-005
CATERPILLAR	D4	w/ 9/16 BOLT	SEALED	1.31	7.00	6.74	A3537	A3540	25499	915137	50-008-002	50-007-005
CATERPILLAR	D4	w/ 9/16 BOLT	SEALED	1.31	7.00	6.74	A3537	A3540	25499	915138	50-008-002	50-007-005
CATERPILLAR	D4		SALT	1.31	7.22	6.74	A3537	A3540	25499	915052	50-008-002	50-007-005
CATERPILLAR	D4B		SEALED	1.13	6.16	6.13	A3536	A3540	200281	915004	50-008-002	50-007-006
CATERPILLAR	D4B		SALT	1.13	6.16	6.13	A3536	A3540	200281	915082	50-008-002	50-007-006
CATERPILLAR	D4C		SEALED	1.13	6.16	6.13	A3536	A3540	200281	915004	50-008-002	50-007-006
CATERPILLAR	D4C		SALT	1.13	6.16	6.13	A3536	A3540	200281	915082	50-008-002	50-007-006
CATERPILLAR	D4C	w/ 1/2 BOLT	SEALED	1.31	7.00	6.74	A3537	A3540	25499	915137	50-008-002	50-007-005
CATERPILLAR	D4C	w/ 9/16 BOLT	SEALED	1.31	7.00	6.74	A3537	A3540	25499	915137	50-008-002	50-007-005
CATERPILLAR	D4C	w/ 9/16 BOLT	SEALED	1.31	7.00	6.74	A3537	A3540	25499	915138	50-008-002	50-007-005
CATERPILLAR	D4D		SEALED	1.31	7.22	6.74	A3537	A3540	25499	915011	50-008-002	50-007-005
CATERPILLAR	D4D		SEALED	1.31	7.00	6.74	A3537	A3540	25499	915002	50-008-002	50-007-005
CATERPILLAR	D4D		SALT	1.31	7.22	6.74	A3537	A3540	25499	915052	50-008-002	50-007-005
CATERPILLAR	D4D	w/ 1/2 BOLT	SEALED	1.31	7.00	6.74	A3537	A3540	25499	915137	50-008-002	50-007-005
CATERPILLAR	D4D	w/ 9/16 BOLT	SEALED	1.31	7.00	6.74	A3537	A3540	25499	915137	50-008-002	50-007-005
CATERPILLAR	D4D	w/ 9/16 BOLT	SEALED	1.31	7.00	6.74	A3537	A3540	25499	915138	50-008-002	50-007-005
CATERPILLAR	D4E		SALT	1.31	7.22	6.74	A3537	A3540	25499	915052	50-008-002	50-007-005
CATERPILLAR	D4G		SEALED	1.13	6.16	6.13	A3536	A3540	200281	915004	50-008-002	50-007-006
CATERPILLAR	D4G		SALT	1.13	6.16	6.13	A3536	A3540	200281	915082	50-008-002	50-007-006
CATERPILLAR	D4H		SALT	1.32	7.22	6.74	A3537	A3540	25499	915124	50-008-002	50-007-005
CATERPILLAR	D4H	HD	SALT	1.42	8.45	6.74	B3635	A3540	25499	915145	50-008-002	50-007-004
CATERPILLAR	D4H	LGP	PPR	1.32	7.29	6.74	A3537	A3540	25499		50-008-002	50-007-005
CATERPILLAR	D4H		SALT	1.32	7.54	6.74	A3537	A3540	25499	915149	50-008-002	50-007-005
CATERPILLAR	D4H	TSK CUS SKD	SALT	1.32	7.54	6.74	A3537	A3540	25499	915149	50-008-002	50-007-005
CATERPILLAR	D5	PRO	SALT	1.44	8.12	6.91	B3635	A3540	25500	915052	50-008-002	50-007-004
CATERPILLAR	D5		SALT	1.44	8.12	6.91	B3635	A3540	25500	915018	50-008-002	50-007-004
CATERPILLAR	D5		SEALED	1.44	8.13	6.91	B3635	A3540	25500	915009	50-008-002	50-007-004
CATERPILLAR	D5		SALT	1.44	8.12	6.91	B3635	A3540	25500	915052	50-008-002	50-007-004
CATERPILLAR	D5B		SEALED	1.44	8.13	6.91	B3635	A3540	25500	915009	50-008-002	50-007-004
CATERPILLAR	D5B		SALT	1.44	8.12	6.91	B3635	A3540	25500	915052	50-008-002	50-007-004
CATERPILLAR	D5C		SALT	1.32	7.54	6.74	A3537	A3540	25499	915149	50-008-002	50-007-005
CATERPILLAR	D5G		SALT	1.32	7.54	6.74	A3537	A3540	25499	915149	50-008-002	50-007-005
CATERPILLAR	D5G	XL	SALT	1.32	7.54	6.74	A3537	A3540	25499	915149	50-008-002	50-007-005
CATERPILLAR	D5H		SALT	1.44	8.12	7.48	B3635	A3540	25500	915052	50-008-002	50-007-004
CATERPILLAR	D5H	TSK CUS SKD	SALT	1.44	8.18	7.48	B3635	A3540	25500	915052	50-008-002	50-007-004



**WTC Machinery
MPP 150 Tooling Chart**

6/9/2022

Make	Model	Comments	Type	Pin Dimensions			Disassembly Tools		Assembly Tools			
				Dia	Length	Pitch	Pin Tool	Back. Bush.	Forcing Pin	PAT (2)	Pin Holder	Bushing
CATERPILLAR	D5H	HD	SALT	1.50	9.39	7.48	B3635	A3540	25500-001	915145	50-008-002	50-007-010
CATERPILLAR	D5M		SALT	1.42	8.45	6.74	B3635	A3540	25499	915145	50-008-002	50-007-004
CATERPILLAR	D5N		SALT	1.42	8.45	6.74	B3635	A3540	25499	915145	50-008-002	50-007-004
CATERPILLAR	D6		RECESS	1.44	8.13	6.74	B3635	A3540	25500	915014	50-008-002	50-007-004
CATERPILLAR	D6		SEALED	1.44	8.13	6.74	B3635	A3540	25500	915009	50-008-002	50-007-004
CATERPILLAR	D6		SALT	1.75	9.06	7.98	B3635	A3541	25548	915081	50-008-002	50-007-002
CATERPILLAR	D6B		SEALED	1.44	8.13	6.74	B3635	A3540	25500	915009	50-008-002	50-007-004
CATERPILLAR	D6C		SEALED	1.25	9.06	7.98	A3537	A3540	25498	915003	50-008-002	50-007-005
CATERPILLAR	D6C		SALT	1.75	9.06	7.98	B3635	A3541	25548	915003	50-008-002	50-007-002
CATERPILLAR	D6D		SEALED	1.25	9.06	7.98	A3537	A3540	25498	915003	50-008-002	50-007-005
CATERPILLAR	D6D		SALT	1.75	9.06	7.98	B3635	A3541	25548	915003	50-008-002	50-007-002
CATERPILLAR	D6E		SALT	1.75	9.06	7.98	B3635	A3541	25548	915003	50-008-002	50-007-002
CATERPILLAR	D6H	LGP	SALT	1.75	9.06	7.98	B3635	A3541	25548	915081	50-008-002	50-007-002
CATERPILLAR	D6H		SALT	1.75	9.06	7.98	B3635	A3541	25548	915081	50-008-002	50-007-002
CATERPILLAR	D6H	LGP	PPR	1.75	9.15	7.98	B3635	A3541	25548	915143	50-008-002	50-007-002
CATERPILLAR	D6H	HD	SALT	1.75	10.32	8.00	B3635	A3541	25548	915143	50-008-002	50-007-002
CATERPILLAR	D6M		SALT	1.50	9.39	7.48	B3635	A3540	25500-001	915145	50-008-002	50-007-010
CATERPILLAR	D6N		SALT	1.50	9.39	7.48	B3635	A3540	25500-001	915145	50-008-002	50-007-010
CATERPILLAR	D6R		SALT	1.75	10.32	8.00	B3635	A3541	25548	915081	50-008-002	50-007-002
CATERPILLAR	D7		SALT	1.88	9.88	8.50	B3815	A3541	25551	915006	50-008-002	50-007-002
CATERPILLAR	D7		SEALED	1.75	9.88	7.98	B3635	A3541	25548	915012	50-008-002	50-007-002
CATERPILLAR	D7		RECESS	1.75	9.88	7.99	B3635	A3541	25548	915012	50-008-002	50-007-002
CATERPILLAR	D7C		SEALED	1.75	9.88	7.98	B3635	A3541	25548	915012	50-008-002	50-007-002
CATERPILLAR	D7D		SEALED	1.75	9.88	7.98	B3635	A3541	25548	915012	50-008-002	50-007-002
CATERPILLAR	D7D		RECESS	1.75	9.88	7.99	B3635	A3541	25548	915012	50-008-002	50-007-002
CATERPILLAR	D7E		SALT	1.88	9.88	8.50	B3815	A3541	25551	915006	50-008-002	50-007-002
CATERPILLAR	D7E		SEALED	1.88	9.88	8.50	B3815	A3541	25551	915012	50-008-002	50-007-002
CATERPILLAR	D7E		SALT	1.88	9.88	8.50	B3815	A3541	25551	915006	50-008-002	50-007-002
CATERPILLAR	D7F		SEALED	1.88	9.88	8.50	B3815	A3541	25551	915012	50-008-002	50-007-002
CATERPILLAR	D7G		SALT	1.88	9.88	8.50	B3815	A3541	25551	915006	50-008-002	50-007-002
CATERPILLAR	D7G	LGP	SALT	1.88	9.88	8.50	B3815	A3541	25551	915006	50-008-002	50-007-002
CATERPILLAR	D7G		SEALED	1.88	9.88	8.50	B3815	A3541	25551	915012	50-008-002	50-007-002
CATERPILLAR	D7H	LGP	PPR	1.88	9.93	8.50	B3815	A3541	25551	915007	50-008-002	50-007-002
CATERPILLAR	D7H		SALT	1.88	9.88	8.50	B3815	A3541	25551	915103	50-008-002	50-007-002
CATERPILLAR	D7H	HD	SALT	1.88	10.88	8.50	B3815	A3541	25551	915150	50-008-002	50-007-002
CATERPILLAR	D7R		SALT	1.88	10.88	8.50	B3815	A3541	25551	915150	50-008-002	50-007-002
CATERPILLAR	D8		RECESS	1.75	11.44	7.95	B3635	A3541	25548	915206	50-008-002	50-007-002
CATERPILLAR	D8		SEALED	1.75	11.44	7.99	B3635	A3541	25548	915013	50-008-002	50-007-002
CATERPILLAR	D8		SALT	2.00	11.44	9.00	B3815	A3541	25551	915007	50-008-002	50-007-001
CATERPILLAR	D8D		SEALED	1.75	11.44	7.99	B3635	A3541	25548	915013	50-008-002	50-007-002
CATERPILLAR	D8E		SEALED	1.75	11.44	7.99	B3635	A3541	25548	915013	50-008-002	50-007-002
CATERPILLAR	D8F		SEALED	1.75	11.44	7.99	B3635	A3541	25548	915013	50-008-002	50-007-002
CATERPILLAR	D8G		SEALED	1.75	11.44	7.99	B3635	A3541	25548	915013	50-008-002	50-007-002
CATERPILLAR	D8H		SALT	2.00	11.44	9.00	B3815	A3541	25551	915007	50-008-002	50-007-001
CATERPILLAR	D8H		SEALED	2.00	11.44	9.00	B3815	A3541	25551	915001	50-008-002	50-007-001
CATERPILLAR	D8K		SALT	2.00	11.44	9.00	B3815	A3541	25551	915007	50-008-002	50-007-001
CATERPILLAR	D8K		SEALED	2.00	11.44	9.00	B3815	A3541	25551	915001	50-008-002	50-007-001



**WTC Machinery
MPP 150 Tooling Chart**

6/9/2022

Make	Model	Comments	Type	Pin Dimensions			Disassembly Tools		Assembly Tools			
				Dia	Length	Pitch	Pin Tool	Back. Bush.	Forcing Pin	PAT (2)	Pin Holder	Bushing
CATERPILLAR	D8L		SALT	1.88	9.88	8.50	B3815	A3541	25551	915006	50-008-002	50-007-002
CATERPILLAR	D8N		SALT	1.88	9.88	8.50	B3815	A3541	25551	915006	50-008-002	50-007-002
CATERPILLAR	D8N		PPR	1.88	9.65	8.50	B3815	A3541	25551	915207	50-008-002	50-007-002
CATERPILLAR	D8R		SALT	1.88	9.88	8.50	B3815	A3541	25551	915006	50-008-002	50-007-002
CATERPILLAR	D8R		PPR	1.88	9.65	8.50	B3815	A3541	25551	915006	50-008-002	50-007-002
CATERPILLAR	D8T		SALT	1.88	9.88	8.50	B3815	A3541	25551	915006	50-008-002	50-007-002
CATERPILLAR	D9		SEALED	2.00	12.00	9.00	B3815	A3541	25551	915208	50-008-002	50-007-001
CATERPILLAR	D9		SALT	2.25	12.25	10.25	B3607/8	A3541	25553	915008	50-020	50-021-2
CATERPILLAR	D9D		SEALED	2.25	12.25	10.25	B3607/8	A3541	25553	915005	50-020	50-021-2
CATERPILLAR	D9E		SEALED	2.25	12.25	10.25	B3607/8	A3541	25553	915005	50-020	50-021-2
CATERPILLAR	D9G		SALT	2.25	12.25	10.25	B3607/8	A3541	25553	915008	50-020	50-021-2
CATERPILLAR	D9G		SEALED	2.25	12.25	10.25	B3607/8	A3541	25553	915005	50-020	50-021-2
CATERPILLAR	D9H		SALT	2.25	12.25	10.25	B3607/8	A3541	25553	915008	50-020	50-021-2
CATERPILLAR	D9H		SEALED	2.25	12.25	10.25	B3607/8	A3541	25553	915005	50-020	50-021-2
CATERPILLAR	D9L		PPR	2.00	10.77	9.00	B3815	A3541	25551	915253	50-008-002	50-007-001
CATERPILLAR	D9L		SALT	2.00	11.44	9.00	B3815	A3541	25551	915093	50-008-002	50-007-001
CATERPILLAR	D9N		SALT	2.00	10.98	9.45	B3815	A3541	25551	915092	50-008-002	50-007-001
CATERPILLAR	D9N		PPR	2.00	10.44	9.45	B3815	A3541	25551	915253	50-008-002	50-007-001
CATERPILLAR	D9R		SALT	2.00	10.98	9.45	B3815	A3541	25551	915092	50-008-002	50-007-001
CATERPILLAR	D9R		PPR	2.00	10.44	9.45	B3815	A3541	25551	915253	50-008-002	50-007-001
CATERPILLAR	E110B		SEALED	1.32	7.01	6.75	A3537	A3540	25499	915059	50-008-002	50-007-005
CATERPILLAR	E120B		SEALED	1.32	7.01	6.75	A3537	A3540	25499	915059	50-008-002	50-007-005
CATERPILLAR	E180		SEALED	1.44	8.13	6.91	B3635	A3540	25500	915128	50-008-002	50-007-004
CATERPILLAR	E200B		SEALED	1.45	8.15	7.50	B3635	A3540	25500	915133	50-008-002	50-007-004
CATERPILLAR	E240		SEALED	1.45	8.15	7.50	B3635	A3540	25500	915133	50-008-002	50-007-004
CATERPILLAR	E300B		SEALED	1.75	9.65	8.00	B3635	A3541	25548	915121	50-008-002	50-007-002
CATERPILLAR	E450		UNSEALED	1.87	10.00	8.50	B3815	A3541	25551	915038	50-008-002	50-007-002
CATERPILLAR	E70		SEALED	0.95	5.51	5.32	A3536	A3539	200281	915129	50-008-002	50-007-007
CATERPILLAR	EL180		SEALED	1.44	8.13	6.91	B3635	A3540	25500	915128	50-008-002	50-007-004
CATERPILLAR	EL200B		SEALED	1.45	8.15	7.50	B3635	A3540	25500	915133	50-008-002	50-007-004
CATERPILLAR	EL240		SEALED	1.45	8.15	7.50	B3635	A3540	25500	915133	50-008-002	50-007-004
CATERPILLAR	EL300A		SEALED	1.75	9.65	8.00	B3635	A3541	25548	915121	50-008-002	50-007-002
CATERPILLAR	EL300B		SEALED	1.75	9.65	8.00	B3635	A3541	25548	915121	50-008-002	50-007-002
CATERPILLAR	EL300B		SEALED	1.75	9.65	8.00	B3635	A3541	25548	915038	50-008-002	50-007-002
CATERPILLAR	FB227		SEALED	1.25	9.06	7.98	A3537	A3540	25498	915003	50-008-002	50-007-005
CATERPILLAR	MHI 180-8		SEALED	1.44	8.13	6.91	B3635	A3540	25500	915128	50-008-002	50-007-004
CATERPILLAR	MHI 180-8LC		SEALED	1.44	8.13	6.91	B3635	A3540	25500	915128	50-008-002	50-007-004
CATERPILLAR	MHI 300LC-8		SEALED	1.75	9.65	8.00	B3635	A3541	25548	915121	50-008-002	50-007-002
CATERPILLAR	PR450		SEALED	1.13	6.16	6.13	A3536	A3540	200281	915004	50-008-002	50-007-006
CATERPILLAR	R2-15-22		RECESS	1.13	6.16	6.13	A3536	A3540	200281	916040	50-008-002	50-007-006
CATERPILLAR	R4		RECESS	1.31	7.00	6.74	A3537	A3540	25499	915011	50-008-002	50-007-005
CATERPILLAR	SF350		SEALED	1.13	6.16	6.13	A3536	A3540	200281	915004	50-008-002	50-007-006
CATERPILLAR	TR225		SEALED	1.13	6.16	6.13	A3536	A3540	200281	915004	50-008-002	50-007-006
DRESSER	150		SEALED	1.38	6.69	6.49	B3635	A3540	25499	915048	50-008-002	50-007-004
DRESSER	175		SEALED	1.63	7.87	6.99	B3635	A3541	25547	915041	50-008-002	50-007-003
DRESSER	500		RECESSED	1.13	5.36	6.00	A3536	A3540	200281	915044	50-008-002	50-007-006
DRESSER	100B		SEALED	1.25	5.97	6.00	A3537	A3540	25498	915034	50-008-002	50-007-005



**WTC Machinery
MPP 150 Tooling Chart**

6/9/2022

Make	Model	Comments	Type	Pin Dimensions			Disassembly Tools		Assembly Tools			
				Dia	Length	Pitch	Pin Tool	Back. Bush.	Forcing Pin	PAT (2)	Pin Holder	Bushing
DRESSER	100C		SEALED	1.25	6.50	6.00	A3537	A3540	25498	915040	50-008-002	50-007-005
DRESSER	100E		SEALED	1.25	6.50	5.99	A3537	A3540	25498	915100	50-008-002	50-007-005
DRESSER	100G		SALT	1.31	6.69	6.49	A3537	A3540	25499	915133	50-008-002	50-007-005
DRESSER	125C		SEALED	1.38	6.69	6.49	B3635	A3540	25499	915048	50-008-002	50-007-004
DRESSER	125E		SEALED	1.38	6.69	6.49	B3635	A3540	25499	915048	50-008-002	50-007-004
DRESSER	125G		SALT	1.31	6.69	6.49	A3537	A3540	25499	915133	50-008-002	50-007-005
DRESSER	125G		SEALED	1.31	6.69	6.49	A3537	A3540	25499	915040	50-008-002	50-007-005
DRESSER	125G		DRY	1.31	6.69	6.49	A3537	A3540	25499	915213	50-008-002	50-007-005
DRESSER	175B		SEALED	1.63	7.87	6.99	B3635	A3541	25547	915041	50-008-002	50-007-003
DRESSER	175B		SEALED	1.75	8.81	7.50	B3635	A3541	25548	915036	50-008-002	50-007-002
DRESSER	175C		SEALED	1.75	8.81	7.50	B3635	A3541	25548	915036	50-008-002	50-007-002
DRESSER	250B		SEALED	1.75	9.31	7.50	B3635	A3541	25548	915036	50-008-002	50-007-002
DRESSER	250C		SEALED	1.75	9.31	7.50	B3635	A3541	25548	915036	50-008-002	50-007-002
DRESSER	500E		DRY	1.13	5.30	5.99	A3536	A3540	200281	915209	50-008-002	50-007-006
DRESSER	D32		SALT	1.31	6.69	6.49	A3537	A3540	25499	915133	50-008-002	50-007-005
DRESSER	D32E		SEALED	1.25	6.50	6.00	A3537	A3540	25498	915040	50-008-002	50-007-005
DRESSER	D32E		SALT	1.31	6.69	6.49	A3537	A3540	25499	915133	50-008-002	50-007-005
DRESSER	D32P		SEALED	1.25	6.50	6.00	A3537	A3540	25498	915040	50-008-002	50-007-005
DRESSER	D32-P1		SALT	1.31	6.69	6.49	A3537	A3540	25499	915133	50-008-002	50-007-005
DRESSER	D38E		SALT	1.31	6.69	6.49	A3537	A3540	25499	915133	50-008-002	50-007-005
DRESSER	D38P-1		SALT	1.31	6.69	6.49	A3537	A3540	25499	915133	50-008-002	50-007-005
DRESSER	D38P-1		SALT	1.31	6.69	6.49	A3537	A3540	25499	915133	50-008-002	50-007-005
DRESSER	D39		SALT	1.31	6.69	6.49	A3537	A3540	25499	915133	50-008-002	50-007-005
DRESSER	D39E		SALT	1.31	6.69	6.49	A3537	A3540	25499	915133	50-008-002	50-007-005
DRESSER	D87E-2		SALT	1.87	10.43	8.50	B3815	A3541	25551	915077	50-008-002	50-007-002
DRESSER	D87P		SALT	1.87	10.43	8.50	B3815	A3541	25551	915077	50-008-002	50-007-002
DRESSER	T340		FLUSH	1.01	4.75	6.00	A3536	A3539	200281	915028	50-008-002	50-007-007
DRESSER	T5		FLUSH	1.01	4.75	6.00	A3536	A3539	200281	915028	50-008-002	50-007-007
DRESSER	T6		SEALED	1.25	5.97	6.00	A3537	A3540	25498	915034	50-008-002	50-007-005
DRESSER	T7		SEALED	1.25	6.50	6.00	A3537	A3540	25498	915040	50-008-002	50-007-005
DRESSER	TD12		SALT	1.50	8.03	7.49	B3635	A3540	25500	915095	50-008-002	50-007-010
DRESSER	TD12		SEALED	1.75	8.03	7.49	B3635	A3541	25548	915095	50-008-002	50-007-002
DRESSER	TD12A		DRY	1.50	8.03	7.49	B3635	A3540	25500	915210	50-008-002	50-007-010
DRESSER	TD12B		DRY	1.50	8.03	7.49	B3635	A3540	25500	915210	50-008-002	50-007-010
DRESSER	TD12C		DRY	1.63	8.81	7.49	B3635	A3541	25547L	915211	50-008-002	50-007-003
DRESSER	TD12C-XP		SEALED	1.63	8.82	7.49	B3635	A3541	25547L	915083	50-008-002	50-007-003
DRESSER	TD14		SEALED	1.63	7.87	6.99	B3635	A3541	25547	915041	50-008-002	50-007-003
DRESSER	TD15		SEALED	1.63	7.87	6.99	B3635	A3541	25547	915041	50-008-002	50-007-003
DRESSER	TD15B		SEALED	1.63	7.87	6.99	B3635	A3541	25547	915041	50-008-002	50-007-003
DRESSER	TD15B		SEALED	1.75	8.81	7.50	B3635	A3541	25548	915036	50-008-002	50-007-002
DRESSER	TD15C		SEALED	1.75	8.81	7.50	B3635	A3541	25548	915036	50-008-002	50-007-002
DRESSER	TD15C		SALT	1.63	8.81	7.49	B3635	A3541	25547L	915021	50-008-002	50-007-003
DRESSER	TD15C	LGP	SALT	1.63	8.81	7.49	B3635	A3541	25547L	915021	50-008-002	50-007-003
DRESSER	TD15C	SPLIT	SEALED	1.63	8.81	7.49	B3635	A3541	25547L	915021	50-008-002	50-007-003
DRESSER	TD15C	SPLIT	DRY	1.63	8.81	7.49	B3635	A3541	25547L	915211	50-008-002	50-007-003
DRESSER	TD15E		SEALED	1.75	8.81	7.98	B3635	A3541	25548	915108	50-008-002	50-007-002
DRESSER	TD15E		SALT	1.75	8.81	7.98	B3635	A3541	25548	915109	50-008-002	50-007-002



**WTC Machinery
MPP 150 Tooling Chart**

6/9/2022

Make	Model	Comments	Type	Pin Dimensions			Disassembly Tools		Assembly Tools			
				Dia	Length	Pitch	Pin Tool	Back. Bush.	Forcing Pin	PAT (2)	Pin Holder	Bushing
DRESSER	TD15E	LGP	SALT	1.75	8.81	7.98	B3635	A3541	25548	915109	50-008-002	50-007-002
DRESSER	TD20B		SEALED	1.75	9.31	7.50	B3635	A3541	25548	915036	50-008-002	50-007-002
DRESSER	TD20C		SEALED	1.75	9.31	7.50	B3635	A3541	25548	915036	50-008-002	50-007-002
DRESSER	TD20C		SEALED	1.88	9.31	8.50	B3815	A3541	25551	915035	50-008-002	50-007-002
DRESSER	TD20E		SALT	1.87	10.43	8.50	B3815	A3541	25551	915077	50-008-002	50-007-002
DRESSER	TD20E		DRY	1.87	10.43	8.50	B3815	A3541	25551	915212	50-008-002	50-007-002
DRESSER	TD20E		SEALED	1.88	10.44	8.50	B3815	A3541	25551	915038	50-008-002	50-007-002
DRESSER	TD20E	SPLIT	SEALED	1.88	10.43	8.50	B3815	A3541	25551	915077	50-008-002	50-007-002
DRESSER	TD20G		SALT	1.87	10.43	8.50	B3815	A3541	25551	915077	50-008-002	50-007-002
DRESSER	TD20G	LGP	SALT	1.87	10.43	8.50	B3815	A3541	25551	915077	50-008-002	50-007-002
DRESSER	TD20G		DRY	1.87	10.43	8.50	B3815	A3541	25551	915212	50-008-002	50-007-002
DRESSER	TD24		SEALED	1.88	11.00	8.50	B3815	A3541	25551	915037	50-008-002	50-007-002
DRESSER	TD25B		SEALED	1.88	11.00	8.50	B3815	A3541	25551	915037	50-008-002	50-007-002
DRESSER	TD25C		SALT	2.13	11.00	9.87	B3607/8	A3541	25501	915102	50-008-002	50-007-001
DRESSER	TD25C		SALT	2.13	11.00	9.86	B3607/8	A3541	25501	915102	50-008-002	50-007-001
DRESSER	TD25C		SEALED	2.13	11.00	9.87	B3607/8	A3541	25501	915102	50-008-002	50-007-001
DRESSER	TD25E		SALT	2.13	11.00	9.87	B3607/8	A3541	25501	915102	50-008-002	50-007-001
DRESSER	TD25E		SALT	2.13	11.00	9.86	B3607/8	A3541	25501	915102	50-008-002	50-007-001
DRESSER	TD25E		SEALED	2.13	11.00	9.87	B3607/8	A3541	25501	915102	50-008-002	50-007-001
DRESSER	TD25E	SPLIT	SEALED	2.13	11.00	9.87	B3607/8	A3541	25501	915102	50-008-002	50-007-001
DRESSER	TD25G		SALT	2.13	11.00	9.87	B3607/8	A3541	25501	915102	50-008-002	50-007-001
DRESSER	TD25G		DRY	2.13	11.00	9.86	B3607/8	A3541	25501	915102	50-008-002	50-007-001
DRESSER	TD30		SALT	2.13	11.00	9.86	B3607/8	A3541	25501	915102	50-008-002	50-007-001
DRESSER	TD30		SEALED	2.13	11.00	9.87	B3607/8	A3541	25501	915102	50-008-002	50-007-001
DRESSER	TD4		FLUSH	1.01	4.75	6.00	A3536	A3539	200281	915028	50-008-002	50-007-007
DRESSER	TD40	SPLIT	SEALED	2.46	12.60	11.02	B3607/8	A3541-001	25553L	915101	50-020	50-021-2
DRESSER	TD40	SPLIT	SALT	2.46	12.60	11.02	B3607/8	A3541-001	25553L	915101	50-020	50-021-2
DRESSER	TD5		FLUSH	1.01	4.75	6.00	A3536	A3539	200281	915028	50-008-002	50-007-007
DRESSER	TD6		SEALED	1.25	5.97	6.00	A3537	A3540	25498	915034	50-008-002	50-007-005
DRESSER	TD7		SEALED	1.25	6.50	6.00	A3537	A3540	25498	915040	50-008-002	50-007-005
DRESSER	TD7C		SEALED	1.25	6.50	6.00	A3537	A3540	25498	915040	50-008-002	50-007-005
DRESSER	TD7E		SEALED	1.25	6.50	5.99	A3537	A3540	25498	915100	50-008-002	50-007-005
DRESSER	TD7G		SALT	1.31	6.69	6.49	A3537	A3540	25499	915133	50-008-002	50-007-005
DRESSER	TD7H		DRY	1.31	6.69	6.49	A3537	A3540	25499	915213	50-008-002	50-007-005
DRESSER	TD8C		SEALED	1.38	6.69	6.49	B3635	A3540	25499	915048	50-008-002	50-007-004
DRESSER	TD8E		SEALED	1.38	6.69	6.49	B3635	A3540	25499	915048	50-008-002	50-007-004
DRESSER	TD8G		SALT	1.31	6.69	6.49	A3537	A3540	25499	915133	50-008-002	50-007-005
DRESSER	TD8G		SEALED	1.31	6.69	6.49	A3537	A3540	25499	915040	50-008-002	50-007-005
DRESSER	TD-8G		DRY	1.31	6.69	6.49	A3537	A3540	25499	915213	50-008-002	50-007-005
DRESSER	TD9B		SEALED	1.38	6.69	6.49	B3635	A3540	25499	915048	50-008-002	50-007-004
DRESSER	TD9H		SALT	1.31	6.69	6.49	A3537	A3540	25499	915133	50-008-002	50-007-005
FIAT	31		SALT	2.37	12.95	11.28	B3607/8	A3541	25553L	915221	50-020	50-021-2
FIAT	31		DRY	2.37	12.95	11.28	B3607/8	A3541	25553L	915142	50-020	50-021-2
FIAT	652		UNSEALED	1.25	6.24	6.00	A3537	A3540	25498	915004	50-008-002	50-007-005
FIAT	653		UNSEALED	1.25	6.24	6.00	A3537	A3540	25498	915004	50-008-002	50-007-005
FIAT	655		UNSEALED	1.25	6.24	6.00	A3537	A3540	25498	915004	50-008-002	50-007-005
FIAT	12G		SEALED	1.88	10.27	7.85	B3815	A3541	25551	915020	50-008-002	50-007-002



**WTC Machinery
MPP 150 Tooling Chart**

6/9/2022

Make	Model	Comments	Type	Pin Dimensions			Disassembly Tools		Assembly Tools			
				Dia	Length	Pitch	Pin Tool	Back. Bush.	Forcing Pin	PAT (2)	Pin Holder	Bushing
FIAT	12G		UNSEALED	1.87	10.27	7.86	B3815	A3541	25551	915020	50-008-002	50-007-002
FIAT	12GB		SEALED	1.88	10.27	7.86	B3815	A3541	25551	915030	50-008-002	50-007-002
FIAT	14B		UNSEALED	1.58	8.66	7.48	B3635	A3540	25547L	915022	50-008-002	50-007-010
FIAT	41B		SALT	2.62	14.00	11.28	B3631/2	A3541-001	25553L	915218	50-020	50-021-3
FIAT	41B		DRY	2.62	14.00	11.28	B3631/2	A3541-001	25553L	915218	50-020	50-021-3
FIAT	AD10		UNSEALED	1.46	7.87	6.93	B3635	A3540	25500	915022	50-008-002	50-007-004
FIAT	AD10B		UNSEALED	1.46	7.87	6.93	B3635	A3540	25500	915022	50-008-002	50-007-004
FIAT	AD12		UNSEALED	1.58	8.66	7.48	B3635	A3540	25547L	915022	50-008-002	50-007-010
FIAT	AD12		SALT	1.58	8.66	6.00	B3635	A3540	25547L	915022	50-008-002	50-007-010
FIAT	AD14		UNSEALED	1.58	8.66	7.48	B3635	A3540	25547L	915022	50-008-002	50-007-010
FIAT	AD14		SALT	1.58	8.66	6.00	B3635	A3540	25547L	915022	50-008-002	50-007-010
FIAT	AD18		UNSEALED	1.87	9.84	8.50	B3815	A3541	25551	915019	50-008-002	50-007-002
FIAT	AD20		UNSEALED	1.87	9.84	8.50	B3815	A3541	25551	915019	50-008-002	50-007-002
FIAT	AD4		UNSEALED	0.98	5.28	5.51	A3536	A3539	200281	915028	50-008-002	50-007-007
FIAT	AD5		UNSEALED	1.18	6.10	6.30	A3536	A3540	25498	915027	50-008-002	50-007-006
FIAT	AD6		UNSEALED	1.38	7.01	6.69	B3635	A3540	25499	915025	50-008-002	50-007-004
FIAT	AD7		UNSEALED	1.38	7.01	6.69	B3635	A3540	25499	915025	50-008-002	50-007-004
FIAT	AD7C		UNSEALED	1.38	7.01	6.69	B3635	A3540	25499	915025	50-008-002	50-007-004
FIAT	AD8		UNSEALED	1.38	7.13	6.69	B3635	A3540	25499	915025	50-008-002	50-007-004
FIAT	AD9		UNSEALED	1.38	7.01	6.69	B3635	A3540	25499	915025	50-008-002	50-007-004
FIAT	B1		UNSEALED	0.98	5.28	5.51	A3536	A3539	200281	915028	50-008-002	50-007-007
FIAT	BD10		UNSEALED	1.46	7.87	6.93	B3635	A3540	25500	915022	50-008-002	50-007-004
FIAT	BD10B		UNSEALED	1.46	7.87	6.93	B3635	A3540	25500	915022	50-008-002	50-007-004
FIAT	BD12		UNSEALED	1.58	8.66	7.48	B3635	A3540	25547L	915022	50-008-002	50-007-010
FIAT	BD12		SALT	1.58	8.66	6.00	B3635	A3540	25547L	915022	50-008-002	50-007-010
FIAT	BD14		UNSEALED	1.58	8.66	7.48	B3635	A3540	25547L	915022	50-008-002	50-007-010
FIAT	BD14		SALT	1.58	8.66	6.00	B3635	A3540	25547L	915022	50-008-002	50-007-010
FIAT	BD18		UNSEALED	1.87	9.84	8.50	B3815	A3541	25551	915019	50-008-002	50-007-002
FIAT	BD20		UNSEALED	1.87	9.84	8.50	B3815	A3541	25551	915019	50-008-002	50-007-002
FIAT	BD7		UNSEALED	1.38	7.01	6.69	B3635	A3540	25499	915025	50-008-002	50-007-004
FIAT	BD7C		UNSEALED	1.38	7.01	6.69	B3635	A3540	25499	915025	50-008-002	50-007-004
FIAT	BD8		UNSEALED	1.38	7.13	6.69	B3635	A3540	25499	915025	50-008-002	50-007-004
FIAT	BD9		UNSEALED	1.38	7.01	6.69	B3635	A3540	25499	915025	50-008-002	50-007-004
FIAT	F318		SEALED	1.38	7.17	6.69	B3635	A3540	25499	915154	50-008-002	50-007-004
FIAT	FA200		SALT	1.58	8.66	6.00	B3635	A3540	25547L	915022	50-008-002	50-007-010
FIAT	FD14		SALT	1.58	8.66	6.00	B3635	A3540	25547L	915022	50-008-002	50-007-010
FIAT	FD20		UNSEALED	1.87	9.84	8.50	B3815	A3541	25551	915019	50-008-002	50-007-002
FIAT	FD20		SALT	1.88	9.90	8.50	B3815	A3541	25551	915006	50-008-002	50-007-002
FIAT	FD30		UNSEALED	2.04	11.66	9.04	B3815	A3541	25551	915016	50-008-002	50-007-001
FIAT	FD30		SALT	2.04	11.65	9.04	B3815	A3541	25551	915105	50-008-002	50-007-001
FIAT	FD31		SEALED	2.37	12.95	11.25	B3607/8	A3541	25553L	915029	50-020	50-021-2
FIAT	FD31		UNSEALED	2.38	12.95	11.25	B3607/8	A3541	25553L	915073	50-020	50-021-2
FIAT	FD31		SALT	2.37	12.95	11.28	B3607/8	A3541	25553L	915094	50-020	50-021-2
FIAT	FD40		UNSEALED	2.38	12.95	11.25	B3607/8	A3541	25553L	915073	50-020	50-021-2
FIAT	FD40		SALT	2.37	12.95	11.28	B3607/8	A3541	25553L	915094	50-020	50-021-2
FIAT	FD40		SALT	2.37	12.95	11.28	B3607/8	A3541	25553L	915221	50-020	50-021-2
FIAT	FD40		DRY	2.37	12.95	11.28	B3607/8	A3541	25553L	915142	50-020	50-021-2



**WTC Machinery
MPP 150 Tooling Chart**

6/9/2022

Make	Model	Comments	Type	Pin Dimensions			Disassembly Tools		Assembly Tools			
				Dia	Length	Pitch	Pin Tool	Back. Bush.	Forcing Pin	PAT (2)	Pin Holder	Bushing
FIAT	FD40B		SALT	2.37	12.95	11.28	B3607/8	A3541	25553L	915221	50-020	50-021-2
FIAT	FD40B		DRY	2.37	12.95	11.28	B3607/8	A3541	25553L	915142	50-020	50-021-2
FIAT	FD5		UNSEALED	1.14	6.46	6.30	A3536	A3540	200281	915120	50-008-002	50-007-006
FIAT	FD5		SALT	1.26	6.42	6.30	A3537	A3540	25498	915130	50-008-002	50-007-005
FIAT	FD50		SALT	2.62	14.00	11.28	B3631/2	A3541-001	25553L	915218	50-020	50-021-3
FIAT	FD50		DRY	2.62	14.00	11.28	B3631/2	A3541-001	25553L	915218	50-020	50-021-3
FIAT	FD7		UNSEALED	1.14	6.46	6.30	A3536	A3540	200281	915120	50-008-002	50-007-006
FIAT	FD7		SALT	1.26	6.42	6.30	A3537	A3540	25498	915130	50-008-002	50-007-005
FIAT	FD9		UNSEALED	1.38	7.17	6.69	B3635	A3540	25499	915014	50-008-002	50-007-004
FIAT	FD9		SALT	1.38	7.17	6.69	B3635	A3540	25499	915014	50-008-002	50-007-004
FIAT	FE16		SEALED	1.38	7.17	6.69	B3635	A3540	25499	915154	50-008-002	50-007-004
FIAT	FE20		SEALED	1.38	7.17	6.69	B3635	A3540	25499	915154	50-008-002	50-007-004
FIAT	FE20LC		SEALED	1.38	7.17	6.69	B3635	A3540	25499	915154	50-008-002	50-007-004
FIAT	FE8LC		SEALED	1.38	7.17	6.69	B3635	A3540	25499	915154	50-008-002	50-007-004
FIAT	FH120		SEALED	1.38	7.17	6.69	B3635	A3540	25499	915154	50-008-002	50-007-004
FIAT	FH150		SEALED	1.38	7.17	6.69	B3635	A3540	25499	915154	50-008-002	50-007-004
FIAT	FH150LC		SEALED	1.38	7.17	6.69	B3635	A3540	25499	915154	50-008-002	50-007-004
FIAT	FH200		SEALED	1.46	8.03	6.93	B3635	A3540	25500	915118	50-008-002	50-007-004
FIAT	FH200LC		SEALED	1.46	8.03	6.93	B3635	A3540	25500	915118	50-008-002	50-007-004
FIAT	FL10		UNSEALED	1.46	7.87	6.93	B3635	A3540	25500	915022	50-008-002	50-007-004
FIAT	FL10B		UNSEALED	1.46	7.87	6.93	B3635	A3540	25500	915022	50-008-002	50-007-004
FIAT	FL12		UNSEALED	1.58	8.66	7.48	B3635	A3540	25547L	915022	50-008-002	50-007-010
FIAT	FL14		UNSEALED	1.58	8.66	7.48	B3635	A3540	25547L	915022	50-008-002	50-007-010
FIAT	FL14		SALT	1.58	8.66	6.00	B3635	A3540	25547L	915022	50-008-002	50-007-010
FIAT	FL14B		UNSEALED	1.58	8.66	7.48	B3635	A3540	25547L	915022	50-008-002	50-007-010
FIAT	FL14C		UNSEALED	1.58	8.66	7.48	B3635	A3540	25547L	915022	50-008-002	50-007-010
FIAT	FL14D		SALT	1.58	8.66	6.00	B3635	A3540	25547L	915022	50-008-002	50-007-010
FIAT	FL14E		SALT	1.58	8.66	6.00	B3635	A3540	25547L	915022	50-008-002	50-007-010
FIAT	FL20	S/N 7607 & DN	UNSEALED	1.87	9.84	8.50	B3815	A3541	25551	915019	50-008-002	50-007-002
FIAT	FL20	7608 & UP	SALT	1.88	9.90	8.50	B3815	A3541	25551	915006	50-008-002	50-007-002
FIAT	FL4AC		UNSEALED	0.98	5.28	5.51	A3536	A3539	200281	915028	50-008-002	50-007-007
FIAT	FL4AD		UNSEALED	0.98	5.28	5.51	A3536	A3539	200281	915028	50-008-002	50-007-007
FIAT	FL4L		UNSEALED	0.98	5.28	5.51	A3536	A3539	200281	915028	50-008-002	50-007-007
FIAT	FL5		UNSEALED	1.14	6.46	6.30	A3536	A3540	200281	915120	50-008-002	50-007-006
FIAT	FL5		SALT	1.26	6.42	6.30	A3537	A3540	25498	915130	50-008-002	50-007-005
FIAT	FL5B		SALT	1.26	6.42	6.30	A3537	A3540	25498	915130	50-008-002	50-007-005
FIAT	FL6		UNSEALED	1.18	6.10	6.30	A3536	A3540	25498	915027	50-008-002	50-007-006
FIAT	FL7		UNSEALED	1.14	6.46	6.30	A3536	A3540	200281	915120	50-008-002	50-007-006
FIAT	FL7		SALT	1.26	6.42	6.30	A3537	A3540	25498	915130	50-008-002	50-007-005
FIAT	FL7		UNSEALED	1.38	7.01	6.69	B3635	A3540	25499	915025	50-008-002	50-007-004
FIAT	FL7B		SALT	1.26	6.42	6.30	A3537	A3540	25498	915130	50-008-002	50-007-005
FIAT	FL8		UNSEALED	1.38	7.01	6.69	B3635	A3540	25499	915025	50-008-002	50-007-004
FIAT	FL8C		UNSEALED	1.38	7.01	6.69	B3635	A3540	25499	915025	50-008-002	50-007-004
FIAT	FL9		UNSEALED	1.38	7.13	6.69	B3635	A3540	25499	915025	50-008-002	50-007-004
FIAT	FP120	S/N 41-3000	SALT	2.37	12.95	11.28	B3607/8	A3541	25553L	915221	50-020	50-021-2
FIAT	FP120	S/N 41-3000	DRY	2.37	12.95	11.28	B3607/8	A3541	25553L	915142	50-020	50-021-2
FIAT	GH11E	S/N 10000 & DN	UNSEALED	1.57	8.14	7.00	B3635	A3540	25547	915214	50-008-002	50-007-010



**WTC Machinery
MPP 150 Tooling Chart**

6/9/2022

Make	Model	Comments	Type	Pin Dimensions			Disassembly Tools		Assembly Tools			
				Dia	Length	Pitch	Pin Tool	Back. Bush.	Forcing Pin	PAT (2)	Pin Holder	Bushing
FIAT	H3			1.25	5.84	6.00	A3537	A3540	25498	915219	50-008-002	50-007-005
FIAT	H4		UNSEALED	1.25	6.24	6.00	A3537	A3540	25498	915004	50-008-002	50-007-005
FIAT	H4			1.25	5.84	6.00	A3537	A3540	25498	915219	50-008-002	50-007-005
FIAT	HD10			1.75	8.37	7.85	B3635	A3541	25548	915220	50-008-002	50-007-002
FIAT	HD11	S/N 7538-10000	SEALED	1.56	8.14	7.00	B3635	A3540	25547	915031	50-008-002	50-007-010
FIAT	HD11	SN 5901 & UP	SEALED	1.62	8.40	7.01	B3635	A3541	25547	915024	50-008-002	50-007-003
FIAT	HD11	S/N 10001 & UP	UNSEALED	1.62	8.40	7.01	B3635	A3541	25547	915024	50-008-002	50-007-003
FIAT	HD11	S/N 1000 & DN	UNSEALED	1.57	8.14	7.01	B3635	A3540	25547	915023	50-008-002	50-007-010
FIAT	HD11B		SEALED	1.62	8.40	7.01	B3635	A3541	25547	915024	50-008-002	50-007-003
FIAT	HD11B	S/N 10001-19484	UNSEALED	1.62	8.40	7.01	B3635	A3541	25547	915024	50-008-002	50-007-003
FIAT	HD11B	S/N 19485 & UP	UNSEALED	1.62	8.60	7.01	B3635	A3541	25547L	915215	50-008-002	50-007-003
FIAT	HD11E	S/N 10000 & DN	SEALED	1.57	8.14	7.01	B3635	A3540	25547	915023	50-008-002	50-007-010
FIAT	HD11G	S/N 8940 & DN	SEALED	1.57	8.14	7.01	B3635	A3540	25547	915023	50-008-002	50-007-010
FIAT	HD11G	S/N 8940 & DN	UNSEALED	1.57	8.14	7.00	B3635	A3540	25547	915214	50-008-002	50-007-010
FIAT	HD11G	S/N 8940 & UP	UNSEALED	1.57	8.14	7.01	B3635	A3540	25547	915023	50-008-002	50-007-010
FIAT	HD14			1.88	9.67	7.85	B3815	A3541	25551	915216	50-008-002	50-007-002
FIAT	HD14			1.88	9.67	7.85	B3815	A3541	25551	915020	50-008-002	50-007-002
FIAT	HD15		UNSEALED	1.75	9.33	7.86	B3635	A3541	25548	915021	50-008-002	50-007-002
FIAT	HD16	S/N 5901 & UP	SEALED	1.88	10.27	7.85	B3815	A3541	25551	915020	50-008-002	50-007-002
FIAT	HD16	S/N 5900 & DN	UNSEALED	1.75	9.33	7.86	B3635	A3541	25548	915021	50-008-002	50-007-002
FIAT	HD16	S/N 5901 & UP	UNSEALED	1.87	10.27	7.86	B3815	A3541	25551	915020	50-008-002	50-007-002
FIAT	HD16B		SEALED	1.88	10.27	7.86	B3815	A3541	25551	915030	50-008-002	50-007-002
FIAT	HD19		SEALED	1.88	11.66	9.01	B3815	A3541	25551	915017	50-008-002	50-007-002
FIAT	HD19		UNSEALED	1.88	11.66	9.00	B3815	A3541	25551	915217	50-008-002	50-007-002
FIAT	HD19		SEALED	1.88	11.66	9.00	B3815	A3541	25551	915017	50-008-002	50-007-002
FIAT	HD20		SEALED	1.88	11.66	9.01	B3815	A3541	25551	915017	50-008-002	50-007-002
FIAT	HD20		UNSEALED	1.88	11.66	9.00	B3815	A3541	25551	915217	50-008-002	50-007-002
FIAT	HD20		SEALED	1.88	11.66	9.00	B3815	A3541	25551	915017	50-008-002	50-007-002
FIAT	HD21	S/N 13871-14942	SEALED	1.88	11.66	9.01	B3815	A3541	25551	915017	50-008-002	50-007-002
FIAT	HD21		UNSEALED	1.88	11.66	9.01	B3815	A3541	25551	915017	50-008-002	50-007-002
FIAT	HD21	S/N14943 & UP	SEALED	1.88	11.66	9.01	B3815	A3541	25551	915017	50-008-002	50-007-002
FIAT	HD21	S/N 14942 & DN	UNSEALED	1.88	11.66	9.01	B3815	A3541	25551	915221	50-008-002	50-007-002
FIAT	HD21B		SEALED	1.88	11.66	9.00	B3815	A3541	25551	915016	50-008-002	50-007-002
FIAT	HD21B		UNSEALED	1.88	11.66	9.00	B3815	A3541	25551	915018	50-008-002	50-007-002
FIAT	HD21C		UNSEALED	2.04	11.66	9.04	B3815	A3541	25551	915016	50-008-002	50-007-001
FIAT	HD21P	S/N 14942 & DN	UNSEALED	1.88	11.66	9.00	B3815	A3541	25551	915217	50-008-002	50-007-002
FIAT	HD21P	S/N 14942 & DN	SEALED	1.88	11.66	9.00	B3815	A3541	25551	915017	50-008-002	50-007-002
FIAT	HD21P	S/N 14943 & UP	UNSEALED	1.88	11.66	9.01	B3815	A3541	25551	915017	50-008-002	50-007-002
FIAT	HD3			1.25	5.84	6.00	A3537	A3540	25498	915219	50-008-002	50-007-005
FIAT	HD31		UNSEALED	2.38	12.95	11.25	B3607/8	A3541	25553L	915073	50-020	50-021-2
FIAT	HD31		SALT	2.37	12.95	11.28	B3607/8	A3541	25553L	915094	50-020	50-021-2
FIAT	HD4	S/N 3001 & UP	UNSEALED	1.25	6.24	6.00	A3537	A3540	25498	915004	50-008-002	50-007-005
FIAT	HD4			1.25	5.84	6.00	A3537	A3540	25498	915219	50-008-002	50-007-005
FIAT	HD41		SEALED	2.37	12.95	11.25	B3607/8	A3541	25553L	915029	50-020	50-021-2
FIAT	HD41		UNSEALED	2.38	12.95	11.25	B3607/8	A3541	25553L	915073	50-020	50-021-2
FIAT	HD41		SALT	2.37	12.95	11.28	B3607/8	A3541	25553L	915094	50-020	50-021-2
FIAT	HD41B		UNSEALED	2.62	14.00	11.28	B3631/2	A3541-001	25553L	915033	50-020	50-021-3



**WTC Machinery
MPP 150 Tooling Chart**

6/9/2022

Make	Model	Comments	Type	Pin Dimensions			Disassembly Tools		Assembly Tools			
				Dia	Length	Pitch	Pin Tool	Back. Bush.	Forcing Pin	PAT (2)	Pin Holder	Bushing
FIAT	HD41B		SALT	2.62	14.00	11.28	B3631/2	A3541-001	25553L	915218	50-020	50-021-3
FIAT	HD5		SEALED	1.38	6.91	6.50	B3635	A3540	25499	915014	50-008-002	50-007-004
FIAT	HD5		UNSEALED	1.38	6.91	6.50	B3635	A3540	25499	915014	50-008-002	50-007-004
FIAT	HD5			1.75	8.37	7.85	B3635	A3541	25548	915220	50-008-002	50-007-002
FIAT	HD50		UNSEALED	2.62	14.00	11.28	B3631/2	A3541-001	25553L	915033	50-020	50-021-3
FIAT	HD50		SALT	2.62	14.00	11.28	B3631/2	A3541-001	25553L	915218	50-020	50-021-3
FIAT	HD50			1.75	8.37	7.85	B3635	A3541	25548	915220	50-008-002	50-007-002
FIAT	HD6		SEALED	1.38	6.91	6.50	B3635	A3540	25499	915014	50-008-002	50-007-004
FIAT	HD6		UNSEALED	1.38	6.91	6.50	B3635	A3540	25499	915014	50-008-002	50-007-004
FIAT	HD7	S/N 1102 & DN	UNSEALED	1.74	7.51	6.50	B3635	A3541	25548	915026	50-008-002	50-007-002
FIAT	HD7	S/N 1103 & UP	UNSEALED	1.57	8.14	6.50	B3635	A3540	25547	915023	50-008-002	50-007-010
FIAT	HD7G		SEALED	1.57	8.14	7.01	B3635	A3540	25547	915023	50-008-002	50-007-010
FIAT	HD7G		UNSEALED	1.57	8.14	7.00	B3635	A3540	25547	915214	50-008-002	50-007-010
FIAT	HD7G		UNSEALED	1.57	8.14	7.01	B3635	A3540	25547	915023	50-008-002	50-007-010
FIAT	HD7G-B		SEALED	1.56	8.14	7.00	B3635	A3540	25547	915031	50-008-002	50-007-010
FIAT	HD9		SEALED	1.57	8.14	7.01	B3635	A3540	25547	915023	50-008-002	50-007-010
FIAT	HD9		UNSEALED	1.57	8.14	7.00	B3635	A3540	25547	915214	50-008-002	50-007-010
FIAT	HD9		UNSEALED	1.57	8.14	7.01	B3635	A3540	25547	915023	50-008-002	50-007-010
FIAT	K		UNSEALED	1.74	7.51	6.50	B3635	A3541	25548	915026	50-008-002	50-007-002
FIAT	KO		UNSEALED	1.74	7.51	6.50	B3635	A3541	25548	915026	50-008-002	50-007-002
FIAT	PH130		SEALED	1.38	7.17	6.69	B3635	A3540	25499	915154	50-008-002	50-007-004
FIAT	S11		SEALED	1.38	7.17	6.69	B3635	A3540	25499	915154	50-008-002	50-007-004
FIAT	S9		SEALED	1.38	7.17	6.69	B3635	A3540	25499	915154	50-008-002	50-007-004
FIAT	SL11	33/281 & UP	SEALED	1.38	7.17	6.69	B3635	A3540	25499	915154	50-008-002	50-007-004
FIAT	SL9	30/241 & UP	SEALED	1.38	7.17	6.69	B3635	A3540	25499	915154	50-008-002	50-007-004
HITACHI	EX100		UNSEALED	1.32	7.28	6.74	A3537	A3540	25499	915223	50-008-002	50-007-005
HITACHI	EX1100		SEALED	2.29	12.58	10.25	B3607/8	A3541	25553L	915171	50-020	50-021-2
HITACHI	EX120		UNSEALED	1.32	7.28	6.74	A3537	A3540	25499	915223	50-008-002	50-007-005
HITACHI	EX1200-5		SEALED	2.29	12.58	10.25	B3607/8	A3541	25553L	915171	50-020	50-021-2
HITACHI	EX150		SEALED	1.38	7.60	6.75	B3635	A3540	25499	915002	50-008-002	50-007-004
HITACHI	EX200		SEALED	1.44	8.35	7.48	B3635	A3540	25500	915134	50-008-002	50-007-004
HITACHI	EX220		SEALED	1.50	8.35	7.48	B3635	A3540	25500	915042	50-008-002	50-007-010
HITACHI	EX300		SEALED	1.75	9.65	8.00	B3635	A3541	25548	915121	50-008-002	50-007-002
HITACHI	EX400		SEALED	1.88	10.00	8.50	B3815	A3541	25551	915012	50-008-002	50-007-002
HITACHI	EX550		SEALED	1.91	11.57	9.00	B3815	A3541	25551	915087	50-008-002	50-007-002
HITACHI	EX700		SEALED	2.19	12.61	10.25	B3607/8	A3541	25501L	915125	50-008-002	50-007-001
HITACHI	EX800		SEALED	2.19	12.61	10.25	B3607/8	A3541	25501L	915125	50-008-002	50-007-001
HITACHI	EX90		UNSEALED	1.32	7.28	6.74	A3537	A3540	25499	915223	50-008-002	50-007-005
HITACHI	UH083		SALT	1.44	8.11	6.91	B3635	A3540	25500	915042	50-008-002	50-007-004
HITACHI	ZX350		SEALED	1.75	9.65	8.00	B3635	A3541	25548	915121	50-008-002	50-007-002
JCB	JS220		SALT	1.75	9.93	8.00	B3635	A3541	25548	915084	50-008-002	50-007-002
JCB	JS300		SALT	1.75	9.93	8.00	B3635	A3541	25548	915084	50-008-002	50-007-002
JCB	JS330		SALT	1.75	9.93	8.00	B3635	A3541	25548	915084	50-008-002	50-007-002
JCB	JS360		SALT	1.75	9.93	8.00	B3635	A3541	25548	915084	50-008-002	50-007-002
JOHN DEERE	50		SEALED	0.87	4.84	5.32	A3536	A3539	200281-001	915027	50-008-002	50-007-008
JOHN DEERE	70		SEALED	1.19	6.10	6.06	A3536	A3540	25498	915025	50-008-002	50-007-006
JOHN DEERE	80		SEALED	0.95	5.16	6.06	A3536	A3539	200281	915074	50-008-002	50-007-007



**WTC Machinery
MPP 150 Tooling Chart**

6/9/2022

Make	Model	Comments	Type	Pin Dimensions			Disassembly Tools		Assembly Tools			
				Dia	Length	Pitch	Pin Tool	Back. Bush.	Forcing Pin	PAT (2)	Pin Holder	Bushing
JOHN DEERE	110		SEALED	1.32	7.01	6.75	A3537	A3540	25499	915002	50-008-002	50-007-005
JOHN DEERE	120		SEALED	1.32	7.01	6.75	A3537	A3540	25499	915002	50-008-002	50-007-005
JOHN DEERE	135		SEALED	1.32	7.01	6.75	A3537	A3540	25499	915002	50-008-002	50-007-005
JOHN DEERE	350		FLUSH	1.19	5.47	5.75	A3536	A3540	25498	915065	50-008-002	50-007-006
JOHN DEERE	370		SEALED	1.87	10.00	8.50	B3815	A3541	25551	915087	50-008-002	50-007-002
JOHN DEERE	440		FLUSH	1.00	5.47	5.75	A3536	A3539	200281	915064	50-008-002	50-007-007
JOHN DEERE	450		FLUSH	1.38	6.08	6.29	B3635	A3540	25499	915056	50-008-002	50-007-004
JOHN DEERE	450		RECESSED	1.38	6.08	6.29	B3635	A3540	25499	915056	50-008-002	50-007-004
JOHN DEERE	490		RECESSED	1.32	6.97	6.75	A3537	A3540	25499	915074	50-008-002	50-007-005
JOHN DEERE	550		SEALED	1.38	6.20	6.29	B3635	A3540	25499	915074	50-008-002	50-007-004
JOHN DEERE	555		SEALED	1.38	6.20	6.29	B3635	A3540	25499	915074	50-008-002	50-007-004
JOHN DEERE	590	S/N 001787 & UP		1.37	7.60	6.75	A3537	A3540	25499	915228	50-008-002	50-007-004
JOHN DEERE	655		SEALED	1.44	8.11	6.91	B3635	A3540	25500	915042	50-008-002	50-007-004
JOHN DEERE	655		SALT	1.44	8.11	6.99	B3635	A3540	25500	915042	50-008-002	50-007-004
JOHN DEERE	700		SALT	1.44	8.11	6.99	B3635	A3540	25500	915042	50-008-002	50-007-004
JOHN DEERE	750		SEALED	1.44	8.11	6.91	B3635	A3540	25500	915042	50-008-002	50-007-004
JOHN DEERE	750		SALT	1.44	8.11	6.99	B3635	A3540	25500	915042	50-008-002	50-007-004
JOHN DEERE	755		SEALED	1.44	8.11	6.91	B3635	A3540	25500	915042	50-008-002	50-007-004
JOHN DEERE	755		SALT	1.44	8.11	6.99	B3635	A3540	25500	915042	50-008-002	50-007-004
JOHN DEERE	790		SEALED	1.50	8.58	7.48	B3635	A3540	25500	915022	50-008-002	50-007-010
JOHN DEERE	792		SEALED	1.75	9.65	8.00	B3635	A3541	25548	915121	50-008-002	50-007-002
JOHN DEERE	850		SEALED	1.75	9.06	8.00	B3635	A3541	25548	915013	50-008-002	50-007-002
JOHN DEERE	855		SEALED	1.88	9.90	8.50	B3815	A3541	25551	915083	50-008-002	50-007-002
JOHN DEERE	855		SALT	1.88	9.88	8.50	B3815	A3541	25551	915006	50-008-002	50-007-002
JOHN DEERE	890		SEALED	1.88	9.90	8.50	B3815	A3541	25551	915083	50-008-002	50-007-002
JOHN DEERE	890		RECESSED	1.88	9.90	8.50	B3815	A3541	25551	915227	50-008-002	50-007-002
JOHN DEERE	990		SEALED	1.88	9.90	8.50	B3815	A3541	25551	915083	50-008-002	50-007-002
JOHN DEERE	1280	EXC		1.44	8.11	6.90	B3635	A3540	25500	915229	50-008-002	50-007-004
JOHN DEERE	2010	S/N 42001 & UP	FLUSH	1.19	5.47	5.75	A3536	A3540	25498	915065	50-008-002	50-007-006
JOHN DEERE	2010	S/N 42000 & DN	FLUSH	1.00	5.47	5.75	A3536	A3539	200281	915064	50-008-002	50-007-007
JOHN DEERE	1050C			2.00	10.31	8.50	B3815	A3541	25551	915172	50-008-002	50-007-001
JOHN DEERE	1050J			2.00	10.31	8.50	B3815	A3541	25551	915172	50-008-002	50-007-001
JOHN DEERE	1150D		SALT	1.44	8.11	6.68	B3635	A3540	25500	915215	50-008-002	50-007-004
JOHN DEERE	1155D		SALT	1.44	8.11	6.68	B3635	A3540	25500	915215	50-008-002	50-007-004
JOHN DEERE	120 EXC		SEALED	1.30	7.24	6.96	A3537	A3540	25499	915059	50-008-002	50-007-005
JOHN DEERE	120C		SEALED	1.32	7.01	6.75	A3537	A3540	25499	915002	50-008-002	50-007-005
JOHN DEERE	160LC		SEALED	1.49	8.37	7.48	B3635	A3540	25500	915042	50-008-002	50-007-010
JOHN DEERE	190E		SEALED	1.19	6.10	6.06	A3536	A3540	25498	915025	50-008-002	50-007-006
JOHN DEERE	190E			1.19	6.10	6.06	A3536	A3540	25498	915230	50-008-002	50-007-006
JOHN DEERE	200LC		SEALED	1.49	8.37	7.48	B3635	A3540	25500	915042	50-008-002	50-007-010
JOHN DEERE	230		SEALED	1.49	8.37	7.48	B3635	A3540	25500	915042	50-008-002	50-007-010
JOHN DEERE	230CLC		SEALED	1.50	8.58	7.48	B3635	A3540	25500	915023	50-008-002	50-007-010
JOHN DEERE	230LC		SEALED	1.50	8.58	7.48	B3635	A3540	25500	915023	50-008-002	50-007-010
JOHN DEERE	230LC		SEALED	1.49	8.37	7.48	B3635	A3540	25500	915042	50-008-002	50-007-010
JOHN DEERE	240D		SEALED	1.50	8.58	7.48	B3635	A3540	25500	915023	50-008-002	50-007-010
JOHN DEERE	270CLC		SEALED	1.76	9.52	8.50	B3635	A3541	25548	915162	50-008-002	50-007-002
JOHN DEERE	270LC		SEALED	1.75	9.65	8.00	B3635	A3541	25548	915121	50-008-002	50-007-002



**WTC Machinery
MPP 150 Tooling Chart**

6/9/2022

Make	Model	Comments	Type	Pin Dimensions			Disassembly Tools		Assembly Tools			
				Dia	Length	Pitch	Pin Tool	Back. Bush.	Forcing Pin	PAT (2)	Pin Holder	Bushing
JOHN DEERE	290D		SEALED	1.18	6.46	6.13	A3536	A3540	25498	915136	50-008-002	50-007-006
JOHN DEERE	291		SEALED	1.18	6.46	6.13	A3536	A3540	25498	915136	50-008-002	50-007-006
JOHN DEERE	330CLC		SEALED	1.76	9.52	8.50	B3635	A3541	25548	915162	50-008-002	50-007-002
JOHN DEERE	330LC	EXC	SEALED	1.76	9.52	8.50	B3635	A3541	25548	915162	50-008-002	50-007-002
JOHN DEERE	350B		FLUSH	1.19	5.47	5.75	A3536	A3540	25498	915065	50-008-002	50-007-006
JOHN DEERE	350C		FLUSH	1.19	5.47	5.75	A3536	A3540	25498	915065	50-008-002	50-007-006
JOHN DEERE	350D		SEALED	1.19	5.38	5.75	A3536	A3540	25498	915027	50-008-002	50-007-006
JOHN DEERE	400G		SEALED	1.19	5.38	5.75	A3536	A3540	25498	915027	50-008-002	50-007-006
JOHN DEERE	420C		FLUSH	1.00	5.47	5.75	A3536	A3539	200281	915064	50-008-002	50-007-007
JOHN DEERE	450B		RECESSED	1.38	6.08	6.29	B3635	A3540	25499	915056	50-008-002	50-007-004
JOHN DEERE	450C	S/N 216337 & DN	RECESSED	1.38	6.08	6.29	B3635	A3540	25499	915056	50-008-002	50-007-004
JOHN DEERE	450C		SALT	1.26	6.38	6.29	A3537	A3540	25498	915014	50-008-002	50-007-005
JOHN DEERE	450C	S/N 216338 & UP	SEALED	1.38	6.20	6.29	B3635	A3540	25499	915074	50-008-002	50-007-004
JOHN DEERE	450CLC		SEALED	1.87	10.00	8.50	B3815	A3541	25551	915087	50-008-002	50-007-002
JOHN DEERE	450D		SEALED	1.26	6.36	6.29	A3537	A3540	25498	915046	50-008-002	50-007-005
JOHN DEERE	450D		SALT	1.26	6.38	6.29	A3537	A3540	25498	915014	50-008-002	50-007-005
JOHN DEERE	450E		SEALED	1.26	6.36	6.29	A3537	A3540	25498	915046	50-008-002	50-007-005
JOHN DEERE	450G		SEALED	1.26	6.36	6.29	A3537	A3540	25498	915046	50-008-002	50-007-005
JOHN DEERE	450G		SALT	1.26	6.38	6.29	A3537	A3540	25498	915014	50-008-002	50-007-005
JOHN DEERE	450H		SEALED	1.26	6.36	6.29	A3537	A3540	25498	915046	50-008-002	50-007-005
JOHN DEERE	450H		SALT	1.26	6.38	6.29	A3537	A3540	25498	915014	50-008-002	50-007-005
JOHN DEERE	450J		SEALED	1.26	6.36	6.29	A3537	A3540	25498	915046	50-008-002	50-007-005
JOHN DEERE	450J		SALT	1.26	6.38	6.29	A3537	A3540	25498	915014	50-008-002	50-007-005
JOHN DEERE	450LC		SEALED	1.87	10.00	8.50	B3815	A3541	25551	915087	50-008-002	50-007-002
JOHN DEERE	455D		SEALED	1.26	6.36	6.29	A3537	A3540	25498	915046	50-008-002	50-007-005
JOHN DEERE	455G		SEALED	1.26	6.36	6.29	A3537	A3540	25498	915046	50-008-002	50-007-005
JOHN DEERE	455G		SALT	1.26	6.38	6.29	A3537	A3540	25498	915014	50-008-002	50-007-005
JOHN DEERE	490D		SEALED	1.32	7.01	6.75	A3537	A3540	25499	915002	50-008-002	50-007-005
JOHN DEERE	490E		SEALED	1.33	6.70	6.73	A3537	A3540	25499	915166	50-008-002	50-007-005
JOHN DEERE	550A		SEALED	1.26	6.36	6.29	A3537	A3540	25498	915046	50-008-002	50-007-005
JOHN DEERE	550A		SALT	1.26	6.38	6.29	A3537	A3540	25498	915014	50-008-002	50-007-005
JOHN DEERE	550B		SEALED	1.26	6.36	6.29	A3537	A3540	25498	915046	50-008-002	50-007-005
JOHN DEERE	550B		SALT	1.26	6.38	6.29	A3537	A3540	25498	915014	50-008-002	50-007-005
JOHN DEERE	550G		SALT	1.26	6.38	6.29	A3537	A3540	25498	915014	50-008-002	50-007-005
JOHN DEERE	550G		SEALED	1.26	6.36	6.29	A3537	A3540	25498	915046	50-008-002	50-007-005
JOHN DEERE	550H		SEALED	1.26	6.36	6.29	A3537	A3540	25498	915046	50-008-002	50-007-005
JOHN DEERE	550H		SALT	1.26	6.38	6.29	A3537	A3540	25498	915014	50-008-002	50-007-005
JOHN DEERE	550J		SALT	1.26	6.38	6.29	A3537	A3540	25498	915014	50-008-002	50-007-005
JOHN DEERE	555G		SALT	1.31	7.24	6.73	A3537	A3540	25499	915089	50-008-002	50-007-005
JOHN DEERE	555G		SEALED	1.32	7.22	6.29	A3537	A3540	25499	915089	50-008-002	50-007-005
JOHN DEERE	590D		SEALED	1.38	7.60	6.75	B3635	A3540	25499	915002	50-008-002	50-007-004
JOHN DEERE	590D	S/N 1787 & UP	SEALED	1.37	7.60	6.75	A3537	A3540	25499	915142	50-008-002	50-007-004
JOHN DEERE	650G		SALT	1.31	7.24	6.73	A3537	A3540	25499	915089	50-008-002	50-007-005
JOHN DEERE	650G		SEALED	1.32	7.22	6.29	A3537	A3540	25499	915089	50-008-002	50-007-005
JOHN DEERE	650H		SALT	1.31	7.24	6.73	A3537	A3540	25499	915089	50-008-002	50-007-005
JOHN DEERE	650H		SEALED	1.32	7.22	6.29	A3537	A3540	25499	915089	50-008-002	50-007-005
JOHN DEERE	650J		SALT	1.31	7.24	6.73	A3537	A3540	25499	915089	50-008-002	50-007-005



**WTC Machinery
MPP 150 Tooling Chart**

6/9/2022

Make	Model	Comments	Type	Pin Dimensions			Disassembly Tools		Assembly Tools			
				Dia	Length	Pitch	Pin Tool	Back. Bush.	Forcing Pin	PAT (2)	Pin Holder	Bushing
JOHN DEERE	650J		SEALED	1.32	7.22	6.29	A3537	A3540	25499	915089	50-008-002	50-007-005
JOHN DEERE	655B		SALT	1.44	8.11	6.99	B3635	A3540	25500	915042	50-008-002	50-007-004
JOHN DEERE	690A		RECESSED	1.32	6.97	6.75	A3537	A3540	25499	915074	50-008-002	50-007-005
JOHN DEERE	690B		RECESSED	1.32	6.97	6.75	A3537	A3540	25499	915074	50-008-002	50-007-005
JOHN DEERE	690C		RECESSED	1.32	6.97	6.75	A3537	A3540	25499	915074	50-008-002	50-007-005
JOHN DEERE	690D		RECESSED	1.32	6.97	6.75	A3537	A3540	25499	915074	50-008-002	50-007-005
JOHN DEERE	690E		SEALED	1.44	8.15	7.48	B3635	A3540	25500	915079	50-008-002	50-007-004
JOHN DEERE	690ELC		SEALED	1.44	8.15	7.48	B3635	A3540	25500	915079	50-008-002	50-007-004
JOHN DEERE	693B		RECESSED	1.32	6.97	6.75	A3537	A3540	25499	915074	50-008-002	50-007-005
JOHN DEERE	693D		SEALED	1.44	8.11	6.91	B3635	A3540	25500	915042	50-008-002	50-007-004
JOHN DEERE	700J		SALT	1.44	8.11	6.99	B3635	A3540	25500	915042	50-008-002	50-007-004
JOHN DEERE	70D		SEALED	1.19	6.10	6.06	A3536	A3540	25498	915025	50-008-002	50-007-006
JOHN DEERE	750B		SEALED	1.44	8.11	6.91	B3635	A3540	25500	915042	50-008-002	50-007-004
JOHN DEERE	750B		SALT	1.44	8.11	6.99	B3635	A3540	25500	915042	50-008-002	50-007-004
JOHN DEERE	750C		SALT	1.44	8.13	7.48	B3635	A3540	25500	915052	50-008-002	50-007-004
JOHN DEERE	750J		SALT	1.50	9.39	7.48	B3635	A3540	25500-001	915080	50-008-002	50-007-010
JOHN DEERE	755A		SEALED	1.75	9.13	7.98	B3635	A3541	25548	915099	50-008-002	50-007-002
JOHN DEERE	755B		SEALED	1.44	8.11	6.91	B3635	A3540	25500	915042	50-008-002	50-007-004
JOHN DEERE	755C		SALT	1.75	9.06	7.98	B3635	A3541	25548	915106	50-008-002	50-007-002
JOHN DEERE	755C		SEALED	1.75	9.06	8.00	B3635	A3541	25548	915013	50-008-002	50-007-002
JOHN DEERE	790D		SEALED	1.50	8.58	7.48	B3635	A3540	25500	915023	50-008-002	50-007-010
JOHN DEERE	790E		SEALED	1.49	8.37	7.48	B3635	A3540	25500	915042	50-008-002	50-007-010
JOHN DEERE	790ELC		SEALED	1.49	8.37	7.48	B3635	A3540	25500	915042	50-008-002	50-007-010
JOHN DEERE	792D		SEALED	1.75	9.65	8.00	B3635	A3541	25548	915121	50-008-002	50-007-002
JOHN DEERE	80C		SEALED	0.95	5.16	6.06	A3536	A3539	200281	915074	50-008-002	50-007-007
JOHN DEERE	850B		SALT	1.75	9.06	7.98	B3635	A3541	25548	915106	50-008-002	50-007-002
JOHN DEERE	850B		SEALED	1.75	9.13	7.98	B3635	A3541	25548	915099	50-008-002	50-007-002
JOHN DEERE	850C		SALT	1.75	9.06	7.98	B3635	A3541	25548	915106	50-008-002	50-007-002
JOHN DEERE	850C		SEALED	1.75	9.06	8.00	B3635	A3541	25548	915013	50-008-002	50-007-002
JOHN DEERE	850J		SALT	1.75	10.32	8.00	B3635	A3541	25548	915175	50-008-002	50-007-002
JOHN DEERE	890A		SEALED	1.88	9.90	8.50	B3815	A3541	25551	915083	50-008-002	50-007-002
JOHN DEERE	892D		SEALED	1.75	9.65	8.00	B3635	A3541	25548	915121	50-008-002	50-007-002
JOHN DEERE	892E		SEALED	1.75	9.65	8.00	B3635	A3541	25548	915121	50-008-002	50-007-002
JOHN DEERE	950J		SALT	1.87	10.86	8.50	B3815	A3541	25551	915189	50-008-002	50-007-002
JOHN DEERE	992D		SEALED	1.87	10.00	8.50	B3815	A3541	25551	915087	50-008-002	50-007-002
JOHN DEERE	992E		SEALED	1.87	10.00	8.50	B3815	A3541	25551	915087	50-008-002	50-007-002
JOHN DEERE	EX120		SEALED	1.32	7.01	6.75	A3537	A3540	25499	915002	50-008-002	50-007-005
JOHN DEERE	EX120-2		SEALED	1.33	6.70	6.73	A3537	A3540	25499	915166	50-008-002	50-007-005
JOHN DEERE	EX150		SEALED	1.38	7.60	6.75	B3635	A3540	25499	915002	50-008-002	50-007-004
JOHN DEERE	JD700		SEALED	1.44	8.11	6.91	B3635	A3540	25500	915042	50-008-002	50-007-004
JOHN DEERE	JD700HLGP		SEALED	1.44	8.11	6.91	B3635	A3540	25500	915042	50-008-002	50-007-004
JOHN DEERE	JD700HLGP		SALT	1.44	8.11	6.91	B3635	A3540	25500	915042	50-008-002	50-007-004
KOBELCO	K909A		UNSEALED	1.50	8.58	7.48	B3635	A3540	25500	915023	50-008-002	50-007-010
KOMATSU	D120-15		SEALED	1.99	11.30	9.00	B3815	A3541	25551	915055	50-008-002	50-007-001
KOMATSU	D120-18		SEALED	1.99	11.30	9.00	B3815	A3541	25551	915055	50-008-002	50-007-001
KOMATSU	D120-8		SEALED	1.99	11.30	9.00	B3815	A3541	25551	915055	50-008-002	50-007-001
KOMATSU	D125-18		RECESSED	1.99	11.30	9.00	B3815	A3541	25551	915206	50-008-002	50-007-001



**WTC Machinery
MPP 150 Tooling Chart**

6/9/2022

Make	Model	Comments	Type	Pin Dimensions			Disassembly Tools		Assembly Tools			
				Dia	Length	Pitch	Pin Tool	Back. Bush.	Forcing Pin	PAT (2)	Pin Holder	Bushing
KOMATSU	D135A-1			1.91	11.58	9.00	B3815	A3541	25551	915087	50-008-002	50-007-002
KOMATSU	D150-1	S/N 6842 & DN	SEALED	1.99	11.30	9.00	B3815	A3541	25551	915055	50-008-002	50-007-001
KOMATSU	D150-1	S/N 6843 & UP	SEALED	1.93	11.54	9.00	B3815	A3541	25551	915086	50-008-002	50-007-002
KOMATSU	D150-1		SALT	1.91	11.57	9.00	B3815	A3541	25551	915055	50-008-002	50-007-002
KOMATSU	D150-1	S/N 6842 & DN	UNSEALED	1.99	11.30	9.00	B3815	A3541	25551	915055	50-008-002	50-007-001
KOMATSU	D150-1	S/N 6843 & UP	UNSEALED	1.93	11.54	9.00	B3815	A3541	25551	915086	50-008-002	50-007-002
KOMATSU	D155		SEALED	1.99	11.30	9.00	B3815	A3541	25551	915055	50-008-002	50-007-001
KOMATSU	D155		SALT	1.91	11.57	9.00	B3815	A3541	25551	915055	50-008-002	50-007-002
KOMATSU	D155-1	S/N 6842 & DN	SEALED	1.99	11.30	9.00	B3815	A3541	25551	915055	50-008-002	50-007-001
KOMATSU	D155-1	S/N 6843 & UP	SEALED	1.93	11.54	9.00	B3815	A3541	25551	915086	50-008-002	50-007-002
KOMATSU	D155-1		SALT	1.91	11.57	9.00	B3815	A3541	25551	915055	50-008-002	50-007-002
KOMATSU	D155-1	S/N 6843 & UP	UNSEALED	1.93	11.54	9.00	B3815	A3541	25551	915086	50-008-002	50-007-002
KOMATSU	D155-1	S/N 6842 & DN	UNSEALED	1.99	11.30	9.00	B3815	A3541	25551	915055	50-008-002	50-007-001
KOMATSU	D155-1	S/N 10263-19064	SEALED	1.91	11.57	9.00	B3815	A3541	25551	915087	50-008-002	50-007-002
KOMATSU	D155-1	S/N 19065 & UP	SALT	1.91	11.57	9.00	B3815	A3541	25551	915087	50-008-002	50-007-002
KOMATSU	D155A		SALT	1.91	11.57	9.00	B3815	A3541	25551	915055	50-008-002	50-007-002
KOMATSU	D155A-1	S/N 2540-10262	SEALED	1.91	11.30	9.00	B3815	A3541	25551	915055	50-008-002	50-007-002
KOMATSU	D155A-2		SALT	1.91	11.57	9.00	B3815	A3541	25551	915087	50-008-002	50-007-002
KOMATSU	D155A-2		SEALED	1.91	11.48	9.00	B3815	A3541	25551	915087	50-008-002	50-007-002
KOMATSU	D155A-5		SEALED	1.91	11.48	9.00	B3815	A3541	25551	915167	50-008-002	50-007-002
KOMATSU	D155AX-3		SEALED	1.91	11.48	9.00	B3815	A3541	25551	915167	50-008-002	50-007-002
KOMATSU	D155AX-5		SEALED	1.91	11.48	9.00	B3815	A3541	25551	915167	50-008-002	50-007-002
KOMATSU	D20		SEALED	0.95	5.63	5.31	A3536	A3539	200281	915124	50-008-002	50-007-007
KOMATSU	D20		SALT	0.95	5.55	5.31	A3536	A3539	200281	915123	50-008-002	50-007-007
KOMATSU	D21		SEALED	0.95	5.63	5.31	A3536	A3539	200281	915124	50-008-002	50-007-007
KOMATSU	D21		SALT	0.95	5.55	5.31	A3536	A3539	200281	915123	50-008-002	50-007-007
KOMATSU	D250		RECESSED	2.17	12.32	10.25	B3607/8	A3541	25501	915054	50-008-002	50-007-001
KOMATSU	D275A-2		SALT	2.24	12.61	10.25	B3607/8	A3541	25501L	915063	50-020	50-021-1
KOMATSU	D275AX	Dual Bushing	SALT	2.07	11.43	10.25	B3815	A3541	25501	915093	50-008-002	50-007-001
KOMATSU	D30-15		SEALED	1.10	6.59	6.06	A3536	A3539	200281	915057	50-008-002	50-007-006
KOMATSU	D30A		SEALED	1.10	6.59	6.06	A3536	A3539	200281	915057	50-008-002	50-007-006
KOMATSU	D30S-1		SEALED	1.09	6.59	6.06	A3536	A3539	200281	915058	50-008-002	50-007-006
KOMATSU	D30S-15	S/N 5016 & UP	SEALED	1.10	6.59	6.06	A3536	A3539	200281	915057	50-008-002	50-007-006
KOMATSU	D31		UNSEALED	1.18	6.69	6.06	A3536	A3540	25498	915069	50-008-002	50-007-006
KOMATSU	D31-15		SEALED	1.10	6.59	6.06	A3536	A3539	200281	915057	50-008-002	50-007-006
KOMATSU	D31-16		SEALED	1.10	6.69	6.06	A3536	A3539	200281	915058	50-008-002	50-007-006
KOMATSU	D31-16		SALT	1.10	6.69	6.06	A3536	A3539	200281	915058	50-008-002	50-007-006
KOMATSU	D31E		SALT	1.10	6.69	6.06	A3536	A3539	200281	915058	50-008-002	50-007-006
KOMATSU	D31E-12		SEALED	1.10	6.59	6.06	A3536	A3539	200281	915057	50-008-002	50-007-006
KOMATSU	D31P		UNSEALED	1.18	6.69	6.06	A3536	A3540	25498	915069	50-008-002	50-007-006
KOMATSU	D31P		SALT	1.10	6.69	6.06	A3536	A3539	200281	915058	50-008-002	50-007-006
KOMATSU	D31P-20		SALT	1.10	6.69	6.06	A3536	A3539	200281	915058	50-008-002	50-007-006
KOMATSU	D31PL		SALT	1.10	6.69	6.06	A3536	A3539	200281	915058	50-008-002	50-007-006
KOMATSU	D31PLL	S/N 29001 & UP	SALT	1.10	6.69	6.06	A3536	A3539	200281	915058	50-008-002	50-007-006
KOMATSU	D31PX		SALT	1.10	6.69	6.06	A3536	A3539	200281	915058	50-008-002	50-007-006
KOMATSU	D31S		SALT	1.10	6.69	6.06	A3536	A3539	200281	915058	50-008-002	50-007-006
KOMATSU	D355		FLUSH	2.24	12.58	10.25	B3607/8	A3541	25501L	915053	50-020	50-021-1



**WTC Machinery
MPP 150 Tooling Chart**

6/9/2022

Make	Model	Comments	Type	Pin Dimensions			Disassembly Tools		Assembly Tools			
				Dia	Length	Pitch	Pin Tool	Back. Bush.	Forcing Pin	PAT (2)	Pin Holder	Bushing
KOMATSU	D355		SALT	2.19	12.74	10.25	B3607/8	A3541	25501L	915091	50-008-002	50-007-001
KOMATSU	D37		SALT	1.10	6.69	6.06	A3536	A3539	200281	915058	50-008-002	50-007-006
KOMATSU	D375		SALT	2.24	12.61	10.25	B3607/8	A3541	25501L	915063	50-020	50-021-1
KOMATSU	D37P		SALT	1.10	6.69	6.06	A3536	A3539	200281	915058	50-008-002	50-007-006
KOMATSU	D39E		SALT	1.31	7.24	6.75	A3537	A3540	25499	915052	50-008-002	50-007-005
KOMATSU	D39EX		SALT	1.31	7.24	6.75	A3537	A3540	25499	915052	50-008-002	50-007-005
KOMATSU	D39P		SALT	1.31	7.24	6.75	A3537	A3540	25499	915052	50-008-002	50-007-005
KOMATSU	D39PX		SALT	1.31	7.24	6.75	A3537	A3540	25499	915052	50-008-002	50-007-005
KOMATSU	D40		RECESSED	1.49	8.58	6.89	B3635	A3540	25500	915059	50-008-002	50-007-010
KOMATSU	D40		SALT	1.38	7.13	6.89	B3635	A3540	25499	915060	50-008-002	50-007-004
KOMATSU	D40		SEALED	1.38	7.17	6.89	B3635	A3540	25499	915060	50-008-002	50-007-004
KOMATSU	D40P-1	BERCO	SEALED	1.50	8.66	6.91	B3635	A3540	25500	915059	50-008-002	50-007-010
KOMATSU	D41	NEW	SALT	1.38	7.17	6.89	B3635	A3540	25499	915122	50-008-002	50-007-004
KOMATSU	D41		UNSEALED	1.50	8.66	6.89	B3635	A3540	25500	915122	50-008-002	50-007-010
KOMATSU	D41		SEALED	1.38	7.17	6.89	B3635	A3540	25499	915060	50-008-002	50-007-004
KOMATSU	D41-6		SALT	1.31	7.24	6.75	A3537	A3540	25499	915052	50-008-002	50-007-005
KOMATSU	D41A	BERCO	SEALED	1.50	8.66	6.91	B3635	A3540	25500	915059	50-008-002	50-007-010
KOMATSU	D41E	S/N 50201 & UP	SALT	1.31	7.22	6.75	A3537	A3540	25499	915067	50-008-002	50-007-005
KOMATSU	D41E		SALT	1.31	7.24	6.75	A3537	A3540	25499	915052	50-008-002	50-007-005
KOMATSU	D41P		SALT	1.31	7.24	6.75	A3537	A3540	25499	915052	50-008-002	50-007-005
KOMATSU	D41P	BERCO	SEALED	1.50	8.66	6.91	B3635	A3540	25500	915059	50-008-002	50-007-010
KOMATSU	D41P-6	S/N 50201 & UP	SALT	1.31	7.22	6.75	A3537	A3540	25499	915067	50-008-002	50-007-005
KOMATSU	D41PX-12		SALT	1.43	7.85	6.88	B3635	A3540	25500	915163	50-008-002	50-007-004
KOMATSU	D41Q-3	BERCO	SEALED	1.50	8.66	6.91	B3635	A3540	25500	915059	50-008-002	50-007-010
KOMATSU	D41S	BERCO	SEALED	1.50	8.66	6.91	B3635	A3540	25500	915059	50-008-002	50-007-010
KOMATSU	D45		RECESSED	1.49	8.58	6.89	B3635	A3540	25500	915059	50-008-002	50-007-010
KOMATSU	D45A		SEALED	1.38	7.17	6.89	B3635	A3540	25499	915059	50-008-002	50-007-004
KOMATSU	D45A	S/N 12178+ BERCO	SEALED	1.50	8.66	6.91	B3635	A3540	25500	915059	50-008-002	50-007-010
KOMATSU	D45B	S/N 12178+ BERCO	SEALED	1.50	8.66	6.91	B3635	A3540	25500	915059	50-008-002	50-007-010
KOMATSU	D45P-1	S/N 1501 & UP	SEALED	1.38	7.17	6.89	B3635	A3540	25499	915059	50-008-002	50-007-004
KOMATSU	D50		RECESSED	1.49	8.58	6.89	B3635	A3540	25500	915059	50-008-002	50-007-010
KOMATSU	D50		SALT	1.38	7.13	6.89	B3635	A3540	25499	915060	50-008-002	50-007-004
KOMATSU	D50		SEALED	1.38	7.17	6.89	B3635	A3540	25499	915060	50-008-002	50-007-004
KOMATSU	D50-11		RECESSED	1.49	8.58	6.89	B3635	A3540	25500	915059	50-008-002	50-007-010
KOMATSU	D50-15		RECESSED	1.49	8.58	6.89	B3635	A3540	25500	915059	50-008-002	50-007-010
KOMATSU	D50-15		SEALED	1.38	7.17	6.89	B3635	A3540	25499	915059	50-008-002	50-007-004
KOMATSU	D50A	BERCO	SEALED	1.50	8.66	6.91	B3635	A3540	25500	915059	50-008-002	50-007-010
KOMATSU	D50B	S/N 10901+ BERCO	SEALED	1.50	8.66	6.91	B3635	A3540	25500	915059	50-008-002	50-007-010
KOMATSU	D50P	S/N 10901+ BERCO	SEALED	1.50	8.66	6.91	B3635	A3540	25500	915059	50-008-002	50-007-010
KOMATSU	D50S	S/N 10901+ BERCO	SEALED	1.50	8.66	6.91	B3635	A3540	25500	915059	50-008-002	50-007-010
KOMATSU	D50S-11		RECESSED	1.49	8.58	6.89	B3635	A3540	25500	915059	50-008-002	50-007-010
KOMATSU	D53	NEW	SALT	1.38	7.17	6.89	B3635	A3540	25499	915122	50-008-002	50-007-004
KOMATSU	D53		UNSEALED	1.50	8.66	6.89	B3635	A3540	25500	915122	50-008-002	50-007-010
KOMATSU	D53		SALT	1.38	7.13	6.89	B3635	A3540	25499	915060	50-008-002	50-007-004
KOMATSU	D53-15		SEALED	1.38	7.17	6.89	B3635	A3540	25499	915059	50-008-002	50-007-004
KOMATSU	D53-16		SEALED	1.38	7.17	6.89	B3635	A3540	25499	915060	50-008-002	50-007-004
KOMATSU	D53A	BERCO	SEALED	1.50	8.66	6.91	B3635	A3540	25500	915059	50-008-002	50-007-010



**WTC Machinery
MPP 150 Tooling Chart**

6/9/2022

Make	Model	Comments	Type	Pin Dimensions			Disassembly Tools		Assembly Tools			
				Dia	Length	Pitch	Pin Tool	Back. Bush.	Forcing Pin	PAT (2)	Pin Holder	Bushing
KOMATSU	D53A-15	S/N 60001 & UP	SEALED	1.38	7.17	6.89	B3635	A3540	25499	915059	50-008-002	50-007-004
KOMATSU	D55		SEALED	1.50	8.66	7.48	B3635	A3540	25500	915060	50-008-002	50-007-010
KOMATSU	D55-S		RECESSED	1.49	8.58	7.48	B3635	A3540	25500	915056	50-008-002	50-007-010
KOMATSU	D57-1		SEALED	1.50	8.66	7.48	B3635	A3540	25500	915060	50-008-002	50-007-010
KOMATSU	D575-1		DRY TRACK	1.50	8.66	7.48	B3635	A3540	25500	915233	50-008-002	50-007-010
KOMATSU	D57S-1		SEALED	1.50	8.66	7.48	B3635	A3540	25500	915060	50-008-002	50-007-010
KOMATSU	D58		SALT	1.38	7.13	6.89	B3635	A3540	25499	915060	50-008-002	50-007-004
KOMATSU	D58		SEALED	1.38	7.17	6.89	B3635	A3540	25499	915060	50-008-002	50-007-004
KOMATSU	D58E	BERCO	SEALED	1.50	8.66	6.91	B3635	A3540	25500	915059	50-008-002	50-007-010
KOMATSU	D58P-1	BERCO	SEALED	1.50	8.66	6.91	B3635	A3540	25500	915059	50-008-002	50-007-010
KOMATSU	D6	S/N 50001-50200	SALT	1.31	7.24	6.75	A3537	A3540	25499	915052	50-008-002	50-007-005
KOMATSU	D60		SEALED	1.76	9.43	8.00	B3635	A3541	25548	915084	50-008-002	50-007-002
KOMATSU	D60		SALT	1.75	9.43	8.00	B3635	A3541	25548	915084	50-008-002	50-007-002
KOMATSU	D60-6		SEALED	1.75	9.26	8.00	B3635	A3541	25548	915062	50-008-002	50-007-002
KOMATSU	D60A	BERCO NON-OEM	SEALED	1.76	9.45	7.98	B3635	A3541	25548	915116	50-008-002	50-007-002
KOMATSU	D60-A		RECESSED	1.49	8.58	7.48	B3635	A3540	25500	915056	50-008-002	50-007-010
KOMATSU	D61		SALT	1.50	8.90	7.48	B3635	A3540	25500	915060	50-008-002	50-007-010
KOMATSU	D61E		SALT	1.50	8.90	7.48	B3635	A3540	25500	915060	50-008-002	50-007-010
KOMATSU	D61EX		SALT	1.50	8.90	7.48	B3635	A3540	25500	915060	50-008-002	50-007-010
KOMATSU	D61P		SALT	1.50	8.90	7.48	B3635	A3540	25500	915060	50-008-002	50-007-010
KOMATSU	D61PX		SALT	1.50	8.90	7.48	B3635	A3540	25500	915060	50-008-002	50-007-010
KOMATSU	D61PX-12		SALT	1.50	8.90	7.48	B3635	A3540	25500	915060	50-008-002	50-007-010
KOMATSU	D63E		SALT	1.38	7.13	6.89	B3635	A3540	25499	915060	50-008-002	50-007-004
KOMATSU	D63E		SEALED	1.38	7.17	6.89	B3635	A3540	25499	915060	50-008-002	50-007-004
KOMATSU	D65		SEALED	1.76	9.43	8.00	B3635	A3541	25548	915084	50-008-002	50-007-002
KOMATSU	D65		SALT	1.75	9.43	8.00	B3635	A3541	25548	915084	50-008-002	50-007-002
KOMATSU	D65-6	S/N 34001 & UP	SALT	1.76	9.53	8.00	B3635	A3541	25548	915097	50-008-002	50-007-002
KOMATSU	D65A	BERCO NON-OEM	SEALED	1.76	9.45	7.98	B3635	A3541	25548	915116	50-008-002	50-007-002
KOMATSU	D65A		SEALED	1.76	9.43	8.00	B3635	A3541	25548	915084	50-008-002	50-007-002
KOMATSU	D65E		SEALED	1.76	9.43	8.00	B3635	A3541	25548	915084	50-008-002	50-007-002
KOMATSU	D65EX-12		SALT	1.75	9.43	8.00	B3635	A3541	25548	915084	50-008-002	50-007-002
KOMATSU	D65EX-15		SALT	1.75	9.43	8.00	B3635	A3541	25548	915084	50-008-002	50-007-002
KOMATSU	D65P-6	S/N 20006 & UP	SEALED	1.76	9.43	8.00	B3635	A3541	25548	915084	50-008-002	50-007-002
KOMATSU	D65PX		SALT	1.75	9.43	8.00	B3635	A3541	25548	915084	50-008-002	50-007-002
KOMATSU	D65PX-12		SALT	1.75	9.43	8.00	B3635	A3541	25548	915084	50-008-002	50-007-002
KOMATSU	D65PX-15		SALT	1.75	9.43	8.00	B3635	A3541	25548	915084	50-008-002	50-007-002
KOMATSU	D66		SEALED	1.76	9.43	8.00	B3635	A3541	25548	915084	50-008-002	50-007-002
KOMATSU	D66		SALT	1.76	9.53	8.00	B3635	A3541	25548	915097	50-008-002	50-007-002
KOMATSU	D68		SEALED	1.76	9.43	8.00	B3635	A3541	25548	915084	50-008-002	50-007-002
KOMATSU	D68		SALT	1.76	9.53	8.00	B3635	A3541	25548	915097	50-008-002	50-007-002
KOMATSU	D75		SEALED	1.84	10.00	8.50	B3635	A3541	25551	915096	50-008-002	50-007-002
KOMATSU	D75		SALT	1.85	10.00	8.50	B3635	A3541	25551	915096	50-008-002	50-007-002
KOMATSU	D75-S		SEALED	1.85	9.84	8.50	B3635	A3541	25551	915015	50-008-002	50-007-002
KOMATSU	D80		SEALED	1.84	10.00	8.50	B3635	A3541	25551	915096	50-008-002	50-007-002
KOMATSU	D80		SALT	1.85	10.00	8.50	B3635	A3541	25551	915096	50-008-002	50-007-002
KOMATSU	D80-7		SEALED	1.75	9.84	8.00	B3635	A3541	25548	915013	50-008-002	50-007-002
KOMATSU	D80-8		SEALED	1.75	9.84	8.00	B3635	A3541	25548	915013	50-008-002	50-007-002



**WTC Machinery
MPP 150 Tooling Chart**

6/9/2022

Make	Model	Comments	Type	Pin Dimensions			Disassembly Tools		Assembly Tools			
				Dia	Length	Pitch	Pin Tool	Back. Bush.	Forcing Pin	PAT (2)	Pin Holder	Bushing
KOMATSU	D85		SEALED	1.77	9.84	8.50	B3635	A3541	25548	915085	50-008-002	50-007-002
KOMATSU	D85		SALT	1.85	10.00	8.50	B3635	A3541	25551	915096	50-008-002	50-007-002
KOMATSU	D85-18	S/N 26514 & UP	SALT	1.85	10.00	8.50	B3635	A3541	25551	915096	50-008-002	50-007-002
KOMATSU	D85-18	S/N 26513 & DN	SEALED	1.85	10.00	8.50	B3635	A3541	25551	915232	50-008-002	50-007-002
KOMATSU	D85A		SEALED	1.77	9.84	8.50	B3635	A3541	25548	915085	50-008-002	50-007-002
KOMATSU	D85A		SEALED	1.84	10.00	8.50	B3635	A3541	25551	915096	50-008-002	50-007-002
KOMATSU	D85A-12		SEALED	1.85	9.84	8.50	B3635	A3541	25551	915015	50-008-002	50-007-002
KOMATSU	D85E		SEALED	1.84	10.00	8.50	B3635	A3541	25551	915096	50-008-002	50-007-002
KOMATSU	D85E-12	S/N 10001 & UP	SEALED	1.77	9.84	8.50	B3635	A3541	25548	915085	50-008-002	50-007-002
KOMATSU	D85E-12		SEALED	1.77	9.84	8.50	B3635	A3541	25548	915085	50-008-002	50-007-002
KOMATSU	D85EX-15		SALT	1.85	10.00	8.50	B3635	A3541	25551	915096	50-008-002	50-007-002
KOMATSU	D85P-18		SEALED	1.84	10.00	8.50	B3635	A3541	25551	915096	50-008-002	50-007-002
KOMATSU	D85PX		SALT	1.85	10.00	8.50	B3635	A3541	25551	915096	50-008-002	50-007-002
KOMATSU	D85PX-15		SALT	1.85	10.00	8.50	B3635	A3541	25551	915096	50-008-002	50-007-002
KOMATSU	D95		SALT	1.85	10.00	8.50	B3635	A3541	25551	915096	50-008-002	50-007-002
KOMATSU	D95		SEALED	1.84	10.00	8.50	B3635	A3541	25551	915096	50-008-002	50-007-002
KOMATSU	D95-S		SEALED	1.77	10.00	8.50	B3635	A3541	25548	915232	50-008-002	50-007-002
KOMATSU	PC100		UNSEALED	1.18	6.69	6.06	A3536	A3540	25498	915069	50-008-002	50-007-006
KOMATSU	PC100	PITCH ALSO 6.89	SEALED	1.18	6.81	6.06	A3536	A3540	25498	915126	50-008-002	50-007-006
KOMATSU	PC100		SEALED	1.18	6.81	6.89	A3536	A3540	25498	915161	50-008-002	50-007-006
KOMATSU	PC100-1		SEALED	1.18	6.54	6.06	A3536	A3540	25498	915110	50-008-002	50-007-006
KOMATSU	PC100-2		SEALED	1.18	6.54	6.06	A3536	A3540	25498	915110	50-008-002	50-007-006
KOMATSU	PC100-3		SEALED	1.18	6.54	6.06	A3536	A3540	25498	915110	50-008-002	50-007-006
KOMATSU	PC100-6		SEALED	1.18	6.81	6.89	A3536	A3540	25498	915161	50-008-002	50-007-006
KOMATSU	PC100L-6		SEALED	1.49	8.66	7.49	B3635	A3540	25500	915060	50-008-002	50-007-010
KOMATSU	PC120		SEALED	1.18	6.81	6.89	A3536	A3540	25498	915161	50-008-002	50-007-006
KOMATSU	PC120	PITCH ALSO 6.89	SEALED	1.18	6.81	6.06	A3536	A3540	25498	915126	50-008-002	50-007-006
KOMATSU	PC120-1		SEALED	1.18	6.54	6.06	A3536	A3540	25498	915110	50-008-002	50-007-006
KOMATSU	PC120-2		SEALED	1.18	6.54	6.06	A3536	A3540	25498	915110	50-008-002	50-007-006
KOMATSU	PC120-3		SEALED	1.18	6.54	6.06	A3536	A3540	25498	915110	50-008-002	50-007-006
KOMATSU	PC120-6			1.18	6.81	6.90	A3536	A3540	25498	915231	50-008-002	50-007-006
KOMATSU	PC120-6			1.18	6.81	6.89	A3536	A3540	25498	915126	50-008-002	50-007-006
KOMATSU	PC120LC-6		SEALED	1.18	6.81	6.89	A3536	A3540	25498	915161	50-008-002	50-007-006
KOMATSU	PC130-6		SEALED	1.18	6.81	6.89	A3536	A3540	25498	915161	50-008-002	50-007-006
KOMATSU	PC138		SEALED	1.18	6.81	6.89	A3536	A3540	25498	915161	50-008-002	50-007-006
KOMATSU	PC150		UNSEALED	1.50	8.66	6.89	B3635	A3540	25500	915122	50-008-002	50-007-010
KOMATSU	PC200		SEALED	1.50	8.66	7.48	B3635	A3540	25500	915060	50-008-002	50-007-010
KOMATSU	PC200-6		SEALED	1.50	8.66	7.48	B3635	A3540	25500	915060	50-008-002	50-007-010
KOMATSU	PC200-7		SEALED	1.50	8.66	7.48	B3635	A3540	25500	915060	50-008-002	50-007-010
KOMATSU	PC200-8		SEALED	1.50	8.66	7.48	B3635	A3540	25500	915060	50-008-002	50-007-010
KOMATSU	PC220		SEALED	1.50	8.66	7.48	B3635	A3540	25500	915060	50-008-002	50-007-010
KOMATSU	PC240LC-6		SEALED	1.50	8.66	7.48	B3635	A3540	25500	915060	50-008-002	50-007-010
KOMATSU	PC250LC-6		SEALED	1.75	9.52	8.50	B3635	A3541	25548	915159	50-008-002	50-007-002
KOMATSU	PC270LC-6		SEALED	1.75	9.52	8.50	B3635	A3541	25548	915159	50-008-002	50-007-002
KOMATSU	PC270LC-7		SEALED	1.75	9.52	8.50	B3635	A3541	25548	915159	50-008-002	50-007-002
KOMATSU	PC300	EXC	SALT	1.75	9.53	8.00	B3635	A3541	25548	915097	50-008-002	50-007-002
KOMATSU	PC300	EXC	SEALED	1.76	9.53	8.00	B3635	A3541	25548	915076	50-008-002	50-007-002



**WTC Machinery
MPP 150 Tooling Chart**

6/9/2022

Make	Model	Comments	Type	Pin Dimensions			Disassembly Tools		Assembly Tools			
				Dia	Length	Pitch	Pin Tool	Back. Bush.	Forcing Pin	PAT (2)	Pin Holder	Bushing
KOMATSU	PC300HD-6		SEALED	1.85	9.92	9.00	B3635	A3541	25551	915160	50-008-002	50-007-002
KOMATSU	PC300LC-6		SEALED	1.75	9.52	8.50	B3635	A3541	25548	915159	50-008-002	50-007-002
KOMATSU	PC300LC-7		SEALED	1.75	9.52	8.50	B3635	A3541	25548	915159	50-008-002	50-007-002
KOMATSU	PC-400 EX		SEALED	1.85	10.00	8.50	B3635	A3541	25551	915232	50-008-002	50-007-002
KOMATSU	PC400-3		SEALED	1.84	10.00	8.50	B3635	A3541	25551	915096	50-008-002	50-007-002
KOMATSU	PC400-5		SEALED	1.84	10.00	8.50	B3635	A3541	25551	915096	50-008-002	50-007-002
KOMATSU	PC400-6		SEALED	1.85	10.00	9.00	B3635	A3541	25551	915096	50-008-002	50-007-002
KOMATSU	PC400-6		SEALED	1.84	10.00	8.50	B3635	A3541	25551	915096	50-008-002	50-007-002
KOMATSU	PC400LC-7		SEALED	1.85	10.00	9.00	B3635	A3541	25551	915096	50-008-002	50-007-002
KOMATSU	PC400LCSE-7		SEALED	1.85	10.00	9.00	B3635	A3541	25551	915096	50-008-002	50-007-002
KOMATSU	PC450		SEALED	1.85	10.00	9.00	B3635	A3541	25551	915096	50-008-002	50-007-002
KOMATSU	PC490LC-10		SEALED	1.93	10.16	9.98	B3815	A3541	25551	915167	50-008-002	50-007-002
KOMATSU	PC60	EXC	SEALED	0.95	5.55	5.31	A3536	A3539	200281	915123	50-008-002	50-007-007
KOMATSU	PC600		SEALED	2.19	12.61	10.25	B3607/8	A3541	25501L	915125	50-008-002	50-007-001
KOMATSU	PC600	EXC	SEALED	1.85	10.00	8.50	B3635	A3541	25551	915232	50-008-002	50-007-002
KOMATSU	PC600-6			1.92	11.41	9.00	B3815	A3541	25551	915177	50-008-002	50-007-002
KOMATSU	PC600-7			1.92	11.41	9.00	B3815	A3541	25551	915177	50-008-002	50-007-002
KOMATSU	PC600LC-6			1.92	11.41	9.00	B3815	A3541	25551	915177	50-008-002	50-007-002
KOMATSU	PC600LC-7			1.92	11.41	9.00	B3815	A3541	25551	915177	50-008-002	50-007-002
KOMATSU	PC650-5		SEALED	2.19	12.61	10.25	B3607/8	A3541	25501L	915125	50-008-002	50-007-001
KOMATSU	PC700		SEALED	2.19	12.61	10.25	B3607/8	A3541	25501L	915125	50-008-002	50-007-001
KOMATSU	PC710		SEALED	2.19	12.61	10.25	B3607/8	A3541	25501L	915125	50-008-002	50-007-001
KOMATSU	PC750		DRY TRACK	2.20	12.61	10.25	B3607/8	A3541	25501L	915125	50-008-002	50-007-001
KOMATSU	PC750SE-6		SEALED	2.19	12.61	10.25	B3607/8	A3541	25501L	915125	50-008-002	50-007-001
KOMATSU	PC80	PITCH ALSO 6.89	SEALED	1.18	6.81	6.06	A3536	A3540	25498	915126	50-008-002	50-007-006
KOMATSU	PC800		SEALED	2.19	12.61	10.25	B3607/8	A3541	25501L	915125	50-008-002	50-007-001
KOMATSU	PC80-1		SEALED	1.18	6.54	6.06	A3536	A3540	25498	915110	50-008-002	50-007-006
KOMATSU	PC80-3		SEALED	1.18	6.54	6.06	A3536	A3540	25498	915110	50-008-002	50-007-006
KUBOTA	KH170L	EXC	UNSEALED	0.99	5.51	5.31	A3536	A3539	200281	915040	50-008-002	50-007-007
LIEBHERR	631	MAY WORK	SALT	1.75	9.06	7.99	B3635	A3541	25548	915003	50-008-002	50-007-002
LIEBHERR	PR711		SALT	1.32	7.22	6.74	A3537	A3540	25499	915052	50-008-002	50-007-005
LIEBHERR	PR721		SALT	1.44	8.12	6.74	B3635	A3540	25500	915052	50-008-002	50-007-004
LIEBHERR	PR731		SALT	1.75	9.06	7.99	B3635	A3541	25548	915003	50-008-002	50-007-002
LIEBHERR	R912		SEALED	1.31	7.00	6.74	A3537	A3540	25499	915002	50-008-002	50-007-005
LIEBHERR	R922		SEALED	1.31	7.00	6.74	A3537	A3540	25499	915002	50-008-002	50-007-005
LIEBHERR	R932		SEALED	1.44	8.13	6.74	B3635	A3540	25500	915009	50-008-002	50-007-004
LINKBELT	LS2800		SEALED	1.44	8.13	6.74	B3635	A3540	25500	915009	50-008-002	50-007-004
LINKBELT	LS4800		SEALED	1.88	9.88	8.50	B3815	A3541	25551	915012	50-008-002	50-007-002
LINKBELT	LS5400		SEALED	1.88	9.88	8.50	B3815	A3541	25551	915012	50-008-002	50-007-002
LINKBELT	LS5800		SEALED	1.88	9.88	8.50	B3815	A3541	25551	915012	50-008-002	50-007-002
LINKBELT	LS6400		SEALED	2.00	11.44	9.00	B3815	A3541	25551	915001	50-008-002	50-007-001
LINKBELT	LS7400		SEALED	2.00	11.44	9.00	B3815	A3541	25551	915001	50-008-002	50-007-001
LINKBELT	LS7800		SEALED	1.44	8.13	6.74	B3635	A3540	25500	915009	50-008-002	50-007-004
LINKBELT	LS9800		SEALED	1.75	9.88	7.99	B3635	A3541	25548	915012	50-008-002	50-007-002
MASSEY-FERG	MF200B		SEALED	1.06	5.75	5.51	A3536	A3539	200281	915004	50-008-002	50-007-007
MASSEY-FERG	MF2244		RECESSED	0.98	5.42	5.51	A3536	A3539	200281	915057	50-008-002	50-007-007
MASSEY-FERG	MF300		RECESSED	1.30	6.61	6.30	A3537	A3540	25498	915002	50-008-002	50-007-005



**WTC Machinery
MPP 150 Tooling Chart**

6/9/2022

Make	Model	Comments	Type	Pin Dimensions			Disassembly Tools		Assembly Tools			
				Dia	Length	Pitch	Pin Tool	Back. Bush.	Forcing Pin	PAT (2)	Pin Holder	Bushing
MASSEY-FERG	MF300		SEALED	1.30	6.61	6.30	A3537	A3540	25498	915078	50-008-002	50-007-005
MASSEY-FERG	MF400C		SEALED	1.38	7.01	6.69	B3635	A3540	25499	915078	50-008-002	50-007-004
MASSEY-FERG	MF450		RECESSED	1.30	6.61	6.30	A3537	A3540	25498	915002	50-008-002	50-007-005
MASSEY-FERG	MF500		RECESSED	1.38	7.17	6.69	B3635	A3540	25499	915080	50-008-002	50-007-004
MASSEY-FERG	MF500B		SEALED	1.44	8.11	6.75	B3635	A3540	25500	915079	50-008-002	50-007-004
MASSEY-FERG	MF600C		SEALED	1.75	8.66	7.98	B3635	A3541	25548	915081	50-008-002	50-007-002
MASSEY-FERG	MFD400C		SEALED	1.38	7.01	6.69	B3635	A3540	25499	915078	50-008-002	50-007-004
MASSEY-FERG	MFD700C		SEALED	1.88	9.88	8.50	B3815	A3541	25551	915062	50-008-002	50-007-002
TEREX	82-20AA,		RECESSED	1.75	9.19	8.00	B3635	A3541	25548	915075	50-008-002	50-007-002
TEREX	82-30		RECESSED	1.75	9.19	8.00	B3635	A3541	25548	915075	50-008-002	50-007-002
TEREX	82-30AA		RECESSED	1.75	11.52	8.00	B3635	A3541	25548	915021	50-008-002	50-007-002
TEREX	82-30B		RECESSED	2.00	11.52	9.00	B3815	A3541	25551	915077	50-008-002	50-007-001
TEREX	82-30FA		RECESSED	1.75	11.52	8.00	B3635	A3541	25548	915021	50-008-002	50-007-002
TEREX	82-40AA		RECESSED	1.75	11.52	8.00	B3635	A3541	25548	915021	50-008-002	50-007-002
TEREX	82-40CA		RECESSED	1.75	11.52	8.00	B3635	A3541	25548	915021	50-008-002	50-007-002
TEREX	82-40DA		RECESSED	2.00	11.52	9.00	B3815	A3541	25551	915077	50-008-002	50-007-001
TEREX	82-50		RECESSED	2.38	12.38	10.31	B3607/8	A3541	25553L	915063	50-020	50-021-2
TEREX	82-80DA		RECESSED	2.00	12.38	9.00	B3815	A3541	25551XL	915076	50-008-002	50-007-001
TEREX	TC-12		RECESSED	2.00	12.38	9.00	B3815	A3541	25551XL	915076	50-008-002	50-007-001
VOLVO	EC150LC			1.50	8.19	7.50	B3635	A3540	25500	915234	50-008-002	50-007-010
VOLVO	EC140BLCM			1.46	8.37	7.51	B3635	A3540	25500	915106	50-008-002	50-007-004
VOLVO	EC210BP			1.46	8.69	7.51	B3635	A3540	25500	915189	50-008-002	50-007-004
VOLVO	EC330BLC			1.85	10.02	8.50	B3635	A3541	25551	915092	50-008-002	50-007-002
VOLVO	EC460BLC			1.88	11.42	8.54	B3815	A3541	25551	915260	50-008-002	50-007-002
VOLVO	EC480DL			1.85	10.63	8.54	B3635	A3541	25551	915260	50-008-002	50-007-002
VOLVO	EC700CL			2.23	12.60	10.24	B3607/8	A3541	25501L	915261	50-020	50-021-1